

Mobile Cylinders

*Product Information, Quick Reference
Data & Application Guide*

Catalog HY18-0001/US



 **WARNING**

FAILURE OR IMPROPER SELECTION OR IMPROPER USE OF THE PRODUCTS AND/OR SYSTEMS DESCRIBED HEREIN OR RELATED ITEMS CAN CAUSE DEATH, PERSONAL INJURY AND PROPERTY DAMAGE.

This document and other information from Parker Hannifin Corporation, its subsidiaries and authorized distributors provide product and/or system options for further investigation by users having technical expertise. It is important that you analyze all aspects of your application and review the information concerning the product or system in the current product catalog. Due to the variety of operating conditions and applications for these products or systems, the user, through its own analysis and testing, is solely responsible for making the final selection of the products and systems and assuring that all performance, safety and warning requirements of the application are met.

The products described herein, including without limitation, product features, specifications, designs, availability and pricing, are subject to change by Parker Hannifin Corporation and its subsidiaries at any time without notice.

Offer of Sale

The items described in this document are hereby offered for sale by Parker Hannifin Corporation, its subsidiaries or its authorized distributors. This offer and its acceptance are governed by the provisions stated in the "Offer of Sale".

© Copyright 2001, Parker Hannifin Corporation, All Rights Reserved

Table of Contents

<i>General Information</i>	4
<i>Ordering Information</i>	6
<i>Closed Length Calculations for Single-Acting Single & Multiple Stage Cylinders</i>	10
<i>Closed Length Calculations for Double-Acting Single & Multiple Stage Cylinders</i>	12
<i>Service Parts, Kits and Tools</i>	14
<i>Normal Maintenance Items</i>	17
<i>Standard Test Procedure for Hydraulic Cylinders</i>	18
<i>Hydraulic Oil Recommendations</i>	19
<i>Front Mount Dump Body Stroke & Lifting Calculations</i>	20
<i>Commodities & Materials Approximate Weights</i>	21
<i>Single Acting Telescopic Cylinder Operation</i>	22
<i>Double Acting Telescopic Cylinder Operation</i>	26
<i>Storage and Installation</i>	29
<i>Hydraulic Theory</i>	30
<i>Designing With Cylinders</i>	31
<i>Designing With Telescopic Cylinders</i>	36
<i>Formulas</i>	40
<i>Troubleshooting Hints</i>	50
<i>Dump Hoist Type Identification Chart</i>	60
<i>Dump Trailer Type Identification Chart</i>	61
<i>Refuse Body Cylinder Application Guide</i>	62
<i>Dump Cylinder Identification Drawings</i>	64
<i>Quick Reference Guide</i>	75
<i>Stock Cylinders</i>	87
<i>Standard Build Piston Rod Cylinders</i>	96
<i>Telescopic Cylinder Application Data Form</i>	104
<i>Piston Rod Cylinder Application Data Form</i>	105
<i>Offer of Sale</i>	106



Cylinders were among the first hydraulic products of Commercial Hydraulics beginning in 1928. In 2000 Commercial Intertech Corp. merged with the Parker Hannifin Corp. Today, the Parker Mobile Cylinder Division is recognized as one of the largest independent manufacturers of hydraulic cylinders for mobile equipment and a leading supplier to refuse, mining, truck, material handling and positioning markets. Parker's Mobile Cylinder Division products include double- and single-acting telescopic cylinders, rod cylinders and "smart cylinders" with internal electronic controls. With manufacturing facilities in Youngstown, OH, Minneapolis, MN, Benton, AR and Geringswalde, Germany, the Parker Mobile Cylinder Division has the resources and expertise to support multi-national markets and customers.

Additionally, the company enjoys a reputation for quality custom built cylinders that demonstrate engineering know how and adept manufacturing. Cylinders represent a significant portion of the company's Hydraulic Systems sales - their contribution has resulted in significant capital expenditures geared to establish Parker's Mobile Cylinder Division as the world's leading manufacturer of hydraulic cylinders.

About our Quick Reference and Application Guide . . .

It's our goal to provide our customers with the highest quality cylinders. If the need arises for a cylinder not listed in this guide, please furnish us the following information and we'll do our best to provide a new or replacement.

- * **OEM identification number**
 - * **Single- or double-acting type**
 - * **Outside diameter of the largest moving stage or rod and bore diameters**
 - * **Number of moving stages**
 - * **Application**
 - * **Retract or closed length**
 - * **Stroke length**
 - * **Extend or open length**
 - * **Pineye sizes**
 - * **Plunger mount type**
 - * **Base mount type**
- Please refer to the cylinder specification data forms for more information.**

Parker's Mobile Cylinder Division has complete manufacturing facilities to fill all your cylinder needs from 1 piece to 1000 pieces. If you're looking for a prototype, a special cylinder, or a production run, Parker's Mobile Cylinder Division is the place to call.

Parker Hannifin Corp.
Mobile Cylinder Div.
P.O. Box 239
Youngstown, OH 44501-0239

Phone: 800-848-5575
Fax: 800-694-3392
E-mail: mcdsales@parker.com
www.parker.com

DISCLAIMER
CROSSOVER AND APPLICATION DATA IS FOR REFERENCE ONLY.
NO OTHER CONDITIONS ARE EXPRESSED OR IMPLIED.

The information in this publication has been independently obtained from a wide variety of sources. However, the publisher disclaims any warranty expressed or implied or any liability or responsibility for the accuracy or correctness of any calculation or information which is critical, it should be independently verified.



**MOBILE CYLINDER DIVISION
PRODUCTS & CAPABILITIES**

- **TELESCOPIC CYLINDERS**
Single Acting
Double Acting
- **SINGLE STAGE “Rod Type” CYLINDERS**
Single Acting
Double Acting
- **BUILD TO CUSTOMER PRINTS OR PER APPLICATION SPECIFICATIONS**
- **BORE SIZES UP TO 20” DIAMETER**
- **STROKE LENGTHS UP TO 500”**
- **OPERATING PRESSURES UP TO 10,000 PSI**
- **VARIOUS OPERATING FLUIDS**
- **BATCH SIZES 1PC TO 100’s**
- **VARIOUS MATERIALS & COATINGS**
Stainless Steel
Electroless Nickel
Nitriding
Chrome
Double Chrome
- **TYPICAL OPTIONS**
Load Holding Valves
Electro-Hydraulic Transducers
End of Stroke Hydraulic Cushions
Protective Rod Boots
Proximity Switches
Flow Controls
Flow Fuses

Hydraulic Cylinder Model Number Coding

The code and model numbers of a Commercial Hydraulics Cylinder are references to its size and type. Using these numbers when ordering or inquiring greatly facilitates accurate understanding.

The following are examples of Commercial Hydraulics cylinder code and model numbers.

Single-acting Telescopic
S63MB-9-120
① ② ③ ④ ⑤ ⑥ ⑦

Double-acting Telescopic
SD96CC-3-199
① ② ③ ④ ⑤ ⑥ ⑦

Double-acting Piston Rod
D72LB-11-83
① ② ④ ⑤ ⑥ ⑦

- S = Single-acting Telescopic or Displacement Cylinder**
(Commercial has also used SA, SF, and H as a prefix)
SD = Double-acting Telescopic Cylinder
D = Double-acting Piston Rod Cylinder
- = Nominal O.D. of the largest moving stage on Single-acting and Double-acting Telescopic cylinders or the Nominal Bore of Double-acting Piston Rod Cylinders**
- = Number of moving stages or sleeves in a Telescopic Cylinder**
- = Mounting option on the body or base end of cylinder**
(See mounting Option and Code Chart for mount descriptions)
- = Mounting option on the rod or plunger end of cylinder**
(See mounting Option and Code Chart for mount descriptions)
- = Modification or design variation of the cylinder**
- = Length of cylinder stroke in inches**

OUR DESIGN ADVANTAGES INCLUDE:

- * Longer sleeve overlap for improved stability and higher column loading.
- * Nylon tipped set screws that conform to the shape of the packing nut threads. It is nearly impossible for the packing nut to back off accidentally.
- * Snap-on, glass-filled bearings that absorb contaminants without damaging cylinder walls.
- * Threaded steel stop rings for easier servicing and more reliable stopping action.
- * External packing nuts give added support to the tube exterior while making service procedures easier.
- * Wave springs and chevron packing for self-compensating seals.
- * Hytrel rod wipers that resist higher temperatures without extrusion.
- * Positive manual air bleeder prevents cavitation and "mushy" cylinder action.
- * Cast steel mountings offer dependable strength. Pin-eye and rod-end are welded into a single unit.

Hydraulic Cylinder Load & Displacements

“ S ” SERIES SINGLE-ACTING, SINGLE & MULTIPLE STAGE CYLINDERS

Sleeve or Plunger O.D. (in inches)	Effective Area in square inches	Load Capacity lbs @ 2000 p.s.i.	Displacement per inch of stroke in gallons *
1.75"	2.41"	4,811	0.010
2.75"	5.94"	11,880	0.026
3.75"	11.04"	22,089	0.048
4.75"	17.72"	35,441	0.077
5.75"	25.97"	51,935	0.112
6.75"	35.78"	71,570	0.155
7.90"	49.02"	98,034	0.212
9.38"	69.03"	138,059	0.299
10.75"	90.76"	181,526	0.393
12.50"	122.72"	245,438	0.531
14.00"	153.94"	307,877	0.666

“ SD ” SERIES DOUBLE-ACTING, MULTIPLE STAGE CYLINDER

Sleeve or Plunger O.D. (in inches)	Bore of Main or Sleeve (in inches)	Effective area (sq. inches) to extend	Effective area (sq. inches) to retract	Load capacity lbs @ 2000 p.s.i. extending	Load capacity lbs @ 2000 p.s.i. retracting	Displacement per inch of stroke (in gallons)* to extend	Displacement per inch of stroke (in gallons)* to retract
1.75"	2.25"	3.98"	1.57"	7,952	3,142	0.017	0.007
2.75"	3.25"	8.29"	2.35"	16,592	4,712	0.036	0.010
3.75"	4.25"	14.18"	3.14"	28,372	6,283	0.061	0.014
4.75"	5.25"	21.64"	3.92"	43,296	7,854	0.094	0.017
5.75"	6.25"	30.68"	4.71"	61,360	9,426	0.133	0.020
6.75"	7.25"	41.28"	5.49"	82,564	10,994	0.179	0.024
7.90"	8.44"	55.68"	6.97"	111,360	13,946	0.242	0.030
9.38"	9.88"	76.59"	7.56"	153,180	15,120	0.332	0.033
10.75"	11.50"	103.87"	13.11"	207,738	26,213	0.450	0.057
12.50"	13.00"	132.73"	10.01"	265,465	20,028	0.575	0.043
14.00"	14.50"	165.13"	11.19"	330,261	22,384	0.715	0.048

Note: The Effective area to RETRACT a Standard “SD” series double acting multiple stage cylinder is the effective area of the PLUNGER (plunger bore area minus the plunger O.D. area).

Example: Retract force for a SD94CC-8-190 (which has 5.75" O.D. plunger and fits in 6.25" bore) would be 9,426 lbs @ 2,000 psi, based on a 4.71 sq. in. effective area.

To calculate effective area in square inches: Multiply diameter times diameter times .78

Example: 5 dia. x 5 dia. = 25 x .78 = 19.63 Square inches of area

To calculate load capacity / cylinder force: Multiply effective area times operating pressure (psi)

Example: 19.63 Square inches x 1750 P.S.I = 34,361 lbs of force

To calculate the required gallons of fluid to extend a cylinder:

Add each “Displacement per inch of stroke” (from chart) for the required sleeve sizes.

Divide this total by the number of moving sleeves, then multiply that total by the desired cylinder stroke.

Note: The “Gallons required to extend” does not include the necessary fluid to fill an empty cylinder.

Example: Required fluid to extend a S83DC-40-134 single-acting telescopic cylinder with following stage sizes:

5.75" O.D.= .112

6.75" O.D.= .155







7.90" O.D.= .210

.477

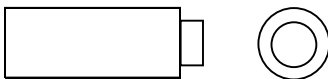
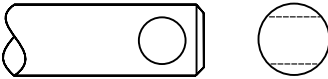
.477 ÷ 3 = .159 gallons per inch of stroke

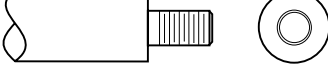
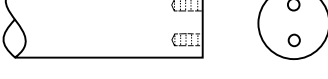
.159 gallons per inch x 134" of stroke = 21.31 gallons to extend cylinder

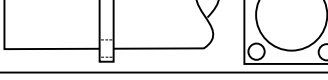
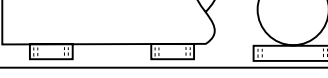
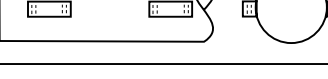
Mounting Options and Code Chart

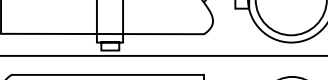
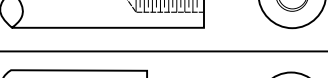
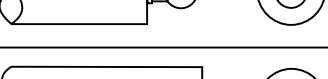
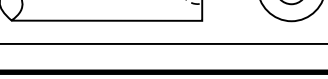
Code Letter	Mount Description	Mount Sketch	Mount Location
A	Plain No Mount		Body or Rod
B	Pin-Eye Drilled Thru Rod		Rod
C	Pin-Eye Drilled Thru Lug		Body or Rod
D	Cross Tube		Body or Rod
E	Threaded		Body or Rod
F	Drilled and Tapped		Body or Rod
G	Flange Mount at Base		Body
H	Flange Mount Mid-Body		Body
J	Foot / Pad Mount		Body
K	Centerline Mount		Body
L	Double Lug Clevis Mount		Body or Rod
M	Trunnion Mount		Body
N	Rod End Drilled and Tapped		Rod
O	Ball Mount		Body or Rod
P	Socket Mount		Body or Rod

Accessories to Modify Cylinder Mounting Pin Hole Diameters and Mount Widths

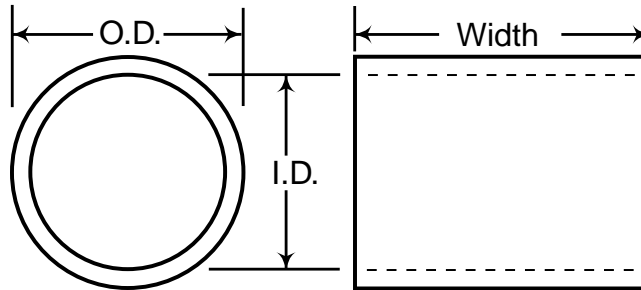

Pin - Eye Mount Bushings

Engineering #	Part Number	Nominal Dimensions
CC1519-1-1.5	375-1519-556	1.50 I.D. X 2.00 O.D. X 1.50 Wide
CC1519-1-2.0	375-1519-557	1.50 I.D. X 2.00 O.D. X 2.00 Wide
CC1519-2-1.5	375-1519-558	1.75 I.D. X 2.00 O.D. X 1.50 Wide
CC1519-2-2.0	375-1519-559	1.75 I.D. X 2.00 O.D. X 2.00 Wide
CC1519-3-2.0	375-1519-560	1.31 I.D. X 2.00 O.D. X 2.00 Wide
CC1519-4-2.0	375-1519-561	1.68 I.D. X 2.00 O.D. X 2.00 Wide

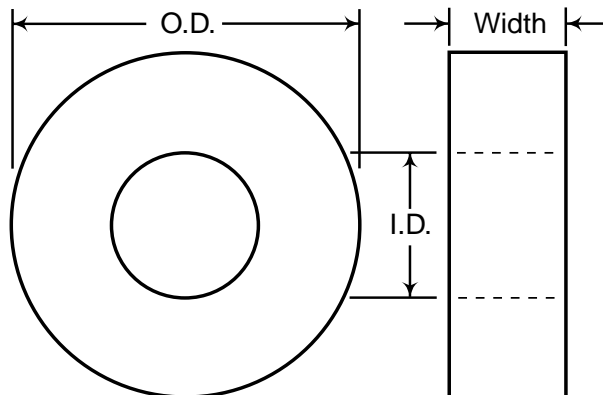

Pin - Eye Mount Spacers

Engineering #	Part Number	Nominal Dimensions
CC1519-5-0.25	375-1519-562	1.81 I.D. X 3.00 O.D. X 0.25 Wide
CC1519-5-0.50	375-1519-563	1.81 I.D. X 3.00 O.D. X 0.50 Wide
CC1519-5-1.0	375-1519-564	1.81 I.D. X 3.00 O.D. X 1.00 Wide
CC1519-5-0.75	375-1519-565	1.81 I.D. X 3.00 O.D. X 0.75 Wide
CC1519-6-0.25	375-1519-566	2.12 I.D. X 3.00 O.D. X 0.25 Wide
CC1519-6-0.50	375-1519-567	2.12 I.D. X 3.00 O.D. X 0.50 Wide
CC1519-6-1.0	375-1519-568	2.12 I.D. X 3.00 O.D. X 1.00 Wide
CC1519-6-0.75	375-1519-569	2.12 I.D. X 3.00 O.D. X 0.75 Wide

Closed Length Calculations for Single-Acting Single & Multiple Stage Cylinders

* Closed length (Lc) for S Models is computed by one of the three equations below. Model number and stroke required determines which equation to use. Example: To find Lc for S41 cylinder with 68" stroke. Under S41 column, use equation III, because the stroke is over 50".

$$L_c = \text{Stroke} + X_1 + X_2 = 68'' + 7.50'' + \frac{(68 - 50)}{10} = 68'' + 7.50'' + (1.8)$$

Use next largest whole number. = 68" + 7.50" + 2" = 77.50".

The closed length (Lc) is 77.50". Add Lc 77.50" to the stroke 68" for extended length of 145.50"

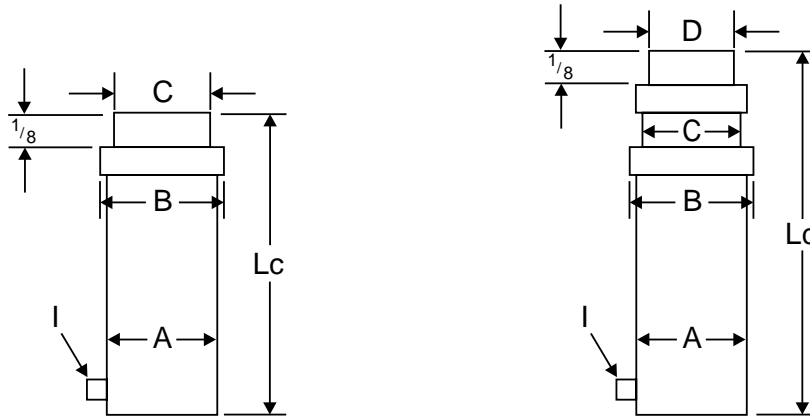

	SINGLE STAGE								2 STAGE								
Cylinder Dimensions (inches)		S31	S41	S51	S61	S71	S81	S91		S42	S52	S62	S72	S82	S92		
Main Cylinder O.D.	A	3 ³ / ₄	4 ³ / ₄	5 ³ / ₄	6 ³ / ₄	8	9 ¹ / ₈	10 ¹³ / ₁₆	A	4 ³ / ₄	5 ³ / ₄	6 ³ / ₄	8	9 ¹ / ₈	10 ¹³ / ₁₆		
Largest Packing Nut O.D.	B	4 ³ / ₈	5 ³ / ₈	6 ³ / ₈	7 ³ / ₈	8 ⁵ / ₈	9 ⁷ / ₈	11 ³ / ₄	B	5 ³ / ₈	6 ³ / ₈	7 ³ / ₈	8 ⁵ / ₈	9 ⁷ / ₈	11 ³ / ₄		
1st Sleeve O.D.	C	2 ³ / ₄	3 ³ / ₄	4 ³ / ₄	5 ³ / ₄	6 ³ / ₄	7 ⁷ / ₈	9 ³ / ₈	C	3 ³ / ₄	4 ³ / ₄	5 ³ / ₄	6 ³ / ₄	7 ⁷ / ₈	9 ³ / ₈		
2nd Sleeve O.D.	D								D	2 ³ / ₄	3 ³ / ₄	4 ³ / ₄	5 ³ / ₄	6 ³ / ₄	7 ⁷ / ₈		
3rd Sleeve O.D.	E								E								
4th Sleeve O.D.	F								F								
5th Sleeve O.D.	G								G								
6th Sleeve O.D.	H								H								
NPT Port	I	3 ³ / ₄	3 ³ / ₄	3 ³ / ₄	1	1	1 ¹ / ₄	1 ¹ / ₄	I	3 ³ / ₄	3 ³ / ₄	1	1	1 ¹ / ₄	1 ¹ / ₄		
Max. Stroke at 2000 PSI		71	84	88	95	118	128	190		126	137	138	164	186	265		
*To Find Closed Length - Lc	X	5.75	5.75	5.75	6.00	6.00	6.50	6.62	X	6.69	6.69	6.94	6.94	7.44	7.56		
Equation I	L _c	Stroke + X up to 35" stroke							O.L. = 1 ¹ / ₄ "	L _c	$\frac{\text{Stroke}}{2} + X$ up to 35" stroke						O.L. = 1 ¹ / ₄ "
Equation II	X ₁	7.50	7.50	7.50	7.75	7.75	8.25	8.38	X ₁	8.44	8.44	8.69	8.69	9.19	9.31		
	L _c	Stroke + X ₁ 36" to 50" stroke							O.L. = 3"	L _c	$\frac{\text{Stroke}}{2} + X_1$ 36" to 50" stroke						O.L. = 3"
Equation III	X ₂	$\frac{\text{Stroke} - 50}{10}$ (To next largest whole number)								X ₂	$\frac{\text{Stroke} - 50}{20}$ (To next largest whole number)						
	L _c	Stroke + X ₁ + X ₂ over 50" stroke							O.L. = 3" + X ₂	L _c	$\frac{\text{Stroke}}{2} + X_1 + X_2$ over 50" stroke						O.L. = 3" + X ₂

Closed Length Calculations for Single-Acting Single & Multiple Stage Cylinders

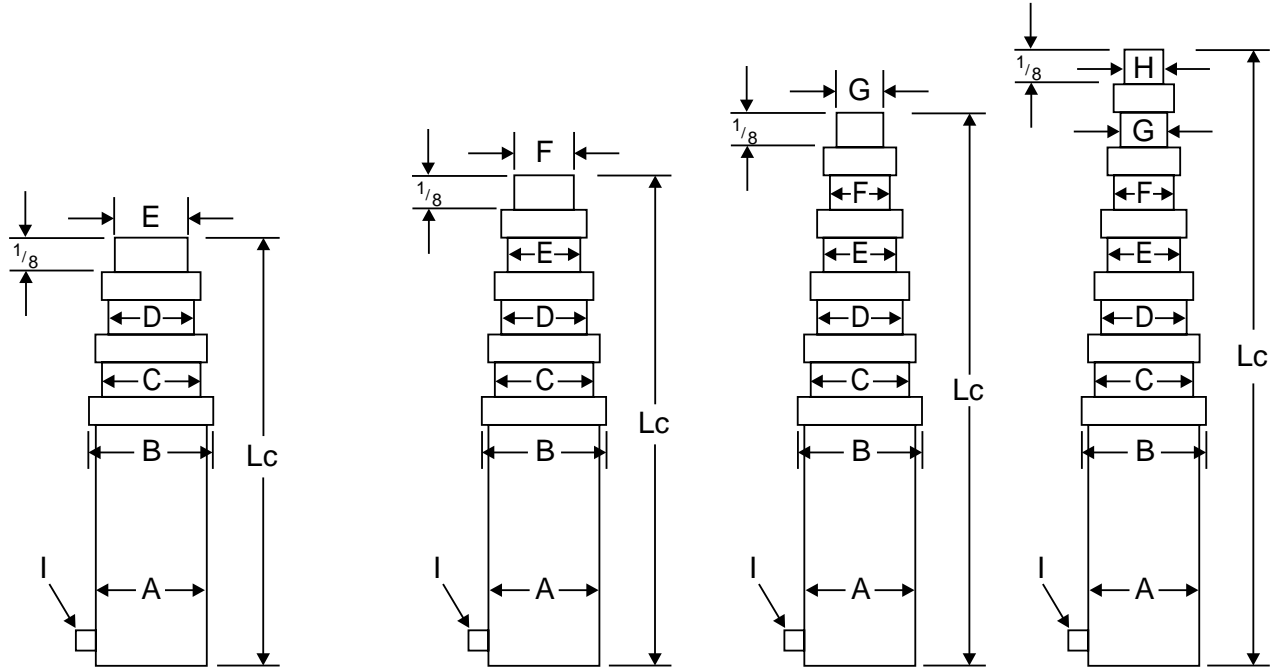

3 STAGE					4 STAGE					5 STAGE				6 STAGE						
	S53	S63	S73	S83	S93		S64	S74	S84	S94		S75	S85	S95		S86	S96			
A	5 ³ / ₄	6 ³ / ₄	8	9 ¹ / ₈	10 ¹³ / ₁₆	A	6 ³ / ₄	8	9 ¹ / ₈	10 ¹³ / ₁₆	A	8	9 ¹ / ₈	10 ¹³ / ₁₆	A	9 ¹ / ₈	10 ¹³ / ₁₆			
B	6 ³ / ₈	7 ³ / ₈	8 ⁵ / ₈	9 ⁷ / ₈	11 ³ / ₄	B	7 ³ / ₈	8 ⁵ / ₈	9 ⁷ / ₈	11 ³ / ₄	B	8 ⁵ / ₈	9 ⁷ / ₈	11 ³ / ₄	B	9 ⁷ / ₈	11 ³ / ₄			
C	4 ³ / ₄	5 ³ / ₄	6 ³ / ₄	7 ⁷ / ₈	9 ³ / ₈	C	5 ³ / ₄	6 ³ / ₄	7 ⁷ / ₈	9 ³ / ₈	C	6 ³ / ₄	7 ⁷ / ₈	9 ³ / ₈	C	7 ⁷ / ₈	9 ³ / ₈			
D	3 ³ / ₄	4 ³ / ₄	5 ³ / ₄	6 ³ / ₄	7 ⁷ / ₈	D	4 ³ / ₄	5 ³ / ₄	6 ³ / ₄	7 ⁷ / ₈	D	5 ³ / ₄	6 ³ / ₄	7 ⁷ / ₈	D	6 ³ / ₄	7 ⁷ / ₈			
E	2 ³ / ₄	3 ³ / ₄	4 ³ / ₄	5 ³ / ₄	6 ³ / ₄	E	3 ³ / ₄	4 ³ / ₄	5 ³ / ₄	6 ³ / ₄	E	4 ³ / ₄	5 ³ / ₄	6 ³ / ₄	E	5 ³ / ₄	6 ³ / ₄			
F						F	2 ³ / ₄	3 ³ / ₄	4 ³ / ₄	5 ³ / ₄	F	3 ³ / ₄	4 ³ / ₄	5 ³ / ₄	F	4 ³ / ₄	5 ³ / ₄			
G						G					G	2 ³ / ₄	3 ³ / ₄	4 ³ / ₄	G	3 ³ / ₄	4 ³ / ₄			
H						H					H				H	2 ³ / ₄	3 ³ / ₄			
I	3/4	1	1	1 ¹ / ₄	1 ¹ / ₄	I	1	1	1 ¹ / ₄	1 ¹ / ₄	I	1	1 ¹ / ₄	1 ¹ / ₄	I	1 ¹ / ₄	1 ¹ / ₄			
	181	186	204	224	312		238	262	265	352		335	336	410		T.B.A.	T.B.A.			
X	7.62	7.88	7.88	8.38	8.50	X	8.81	8.81	9.31	9.44	X	9.75	10.25	10.38	X	11.19	11.31			
L _c	$\frac{\text{Stroke}}{3} + X$ O.L. = 1 ¹ / ₄ " up to 50" stroke					L _c	$\frac{\text{Stroke}}{4} + X$ O.L. = 1 ¹ / ₄ " up to 70" stroke					L _c	$\frac{\text{Stroke}}{5} + X$ O.L. = 1 ¹ / ₄ " up to 85" stroke				L _c	$\frac{\text{Stroke}}{6} + X$ O.L. = 1 ¹ / ₄ " up to 100" stroke		
X ₁	9.38	9.62	9.62	10.12	10.25	X ₁	10.56	10.56	11.06	11.19	X ₁	11.50	12.00	12.12	X ₁	12.94	13.06			
L _c	$\frac{\text{Stroke}}{3} + X_1$ O.L. = 3" 51" to 75" stroke					L _c	$\frac{\text{Stroke}}{4} + X_1$ O.L. = 3" 71" to 100"					L _c	$\frac{\text{Stroke}}{5} + X_1$ O.L. = 3" 86" to 125" stroke				L _c	$\frac{\text{Stroke}}{6} + X_1$ O.L. = 3" 101" to 150" stroke		
X ₂	$\frac{\text{Stroke} - 75}{30}$ (To next largest whole number)					X ₂	$\frac{\text{Stroke} - 100}{40}$ (To next largest whole number)					X ₂	$\frac{\text{Stroke} - 125}{50}$ (To next largest whole number)				X ₂	$\frac{\text{Stroke} - 150}{60}$ (To next largest whole number)		
L _c	$\frac{\text{Stroke}}{3} + X_1 + X_2$ O.L. = 3" + X ₂ over 75" stroke					L _c	$\frac{\text{Stroke}}{4} + X_1 + X_2$ O.L. = 3" + X ₂ over 100" stroke					L _c	$\frac{\text{Stroke}}{5} + X_1 + X_2$ O.L. = 3" + X ₂ over 125" stroke				L _c	$\frac{\text{Stroke}}{6} + X_1 + X_2$ O.L. = 3" + X ₂ over 150" stroke		

Closed Length Calculations for Double-Acting Single & Multiple Stage Cylinders

* Closed length (Lc) for SD Models is computed by one of the three equations below. Model number and stroke required determines which equation to use. Example: To find Lc for SD41 cylinder with 68" stroke. Under SD41 column, use equation III, because the stroke is over 66".

$$L_c = \text{Stroke} + X_1 + X_2 = 68" + 12" + \frac{68 - 50}{4.5} = 68" + 12" + (.666).$$

Use next largest whole number. = 68" + 12" + 1" = 81".

The closed length (Lc) is 81". Add Lc 81" to the stroke 68" for extended length of 149"

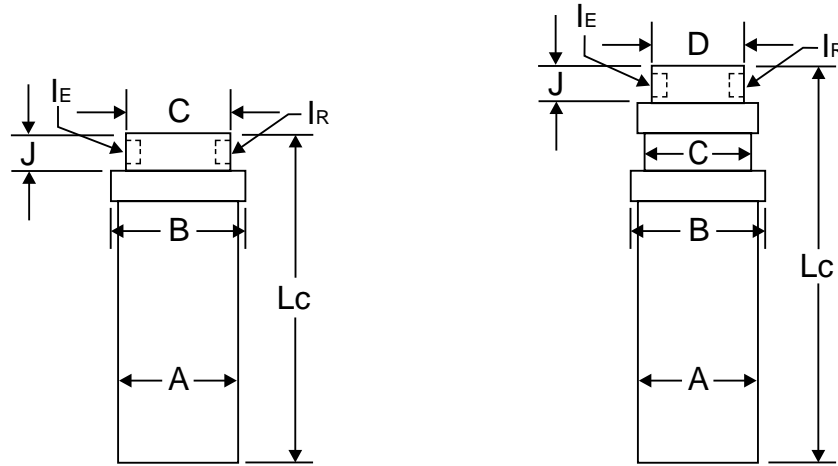

Cylinder Dimensions (inches)	SINGLE STAGE								2 STAGE							
		SD31	SD41	SD51	SD61	SD71	SD81	SD91		SD42	SD52	SD62	SD72	SD82	SD92	
Main Cylinder O.D.	A	3 ³ / ₄	4 ³ / ₄	5 ³ / ₄	6 ³ / ₄	8	9 ¹ / ₈	10 ¹³ / ₁₆	A	4 ³ / ₄	5 ³ / ₄	6 ³ / ₄	8	9 ¹ / ₈	10 ¹³ / ₁₆	
Largest Packing Nut O.D.	B	4 ³ / ₈	5 ³ / ₈	6 ³ / ₈	7 ³ / ₈	8 ⁵ / ₈	9 ⁷ / ₈	11 ³ / ₄	B	5 ³ / ₈	6 ³ / ₈	7 ³ / ₈	8 ⁵ / ₈	9 ⁷ / ₈	11 ³ / ₄	
1st Sleeve O.D.	C	2 ³ / ₄	3 ³ / ₄	4 ³ / ₄	5 ³ / ₄	6 ³ / ₄	7 ⁷ / ₈	9 ³ / ₈	C	3 ³ / ₄	4 ³ / ₄	5 ³ / ₄	6 ³ / ₄	7 ⁷ / ₈	9 ³ / ₈	
2nd Sleeve O.D.	D								D	2 ³ / ₄	3 ³ / ₄	4 ³ / ₄	5 ³ / ₄	6 ³ / ₄	7 ⁷ / ₈	
3rd Sleeve O.D.	E								E							
4th Sleeve O.D.	F								F							
5th Sleeve O.D.	G								G							
6th Sleeve O.D.	H								H							
NPT Port - Extend	I _E	3/4	3/4	3/4	1	1	1 1/4	1 1/4	I _E	3/4	1	1	1 1/4	1 1/4	1 1/4	
NPT Port - Retract	I _R	1/2	1/2	1/2	3/4	3/4	1	1	I _R	1/2	3/4	3/4	1	1	1	
Plunger Extension	J	1 5/8	1 5/8	1 5/8	2 1/8	2 1/8	2 5/8	2 5/8	J	1 5/8	2 1/8	2 1/8	2 5/8	2 5/8	2 5/8	
Max. Recommended Ext. Lgth. at 2000 PSI		131	155	170	186	235	272	386		171	184	199	241	275	390	
Max. Stroke at 2000 PSI		59	70	77	84	106	122	174		100	108	117	142	162	234	
*To Find Closed Length - Lc	X	9.38	9.38	9.38	10.12	10.12	11.12	11.25	X	13.00	13.50	13.75	14.50	14.75	14.88	
Equation I	L _C	Stroke + X up to 45" stroke O.L. = 3 3/8"								L _C	Stroke 2 + X up to 95" stroke O.L. = 6"					
Equation II	X ₁	12.00	12.00	12.00	12.75	12.75	13.75	13.88	X ₁	Stroke - 95 6 (To next largest whole number)						
	L _C	Stroke + X ₁ 46" to 65" stroke O.L. = 6"								L _C	Stroke 2 + X + X ₁ 95" stroke to max. O.L. = 6" + X ₁					
Equation III	X ₂	Stroke - 65 4.5 (To next largest whole number)								X ₂	Not Required					
	L _C	Stroke + X ₁ + X ₂ 66" stroke to max.								L _C	Not Required					

Closed Length Calculations for Double-Acting Single & Multiple Stage Cylinders

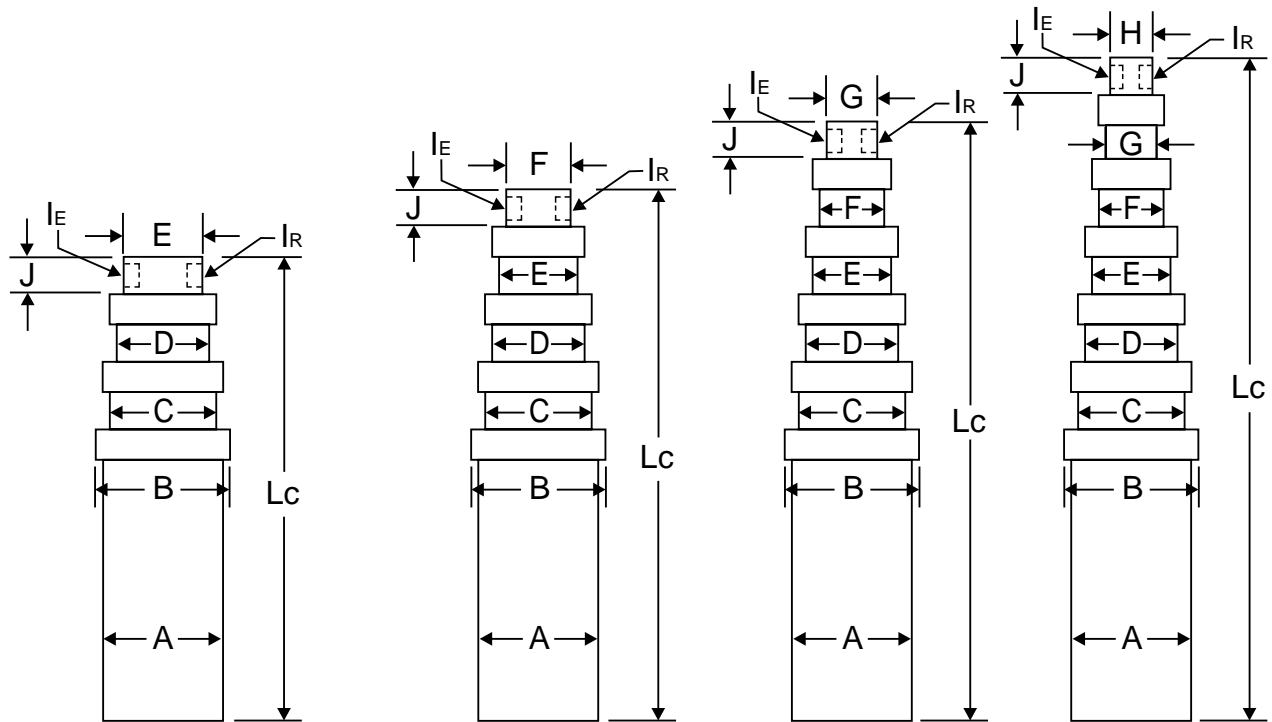

3 STAGE					4 STAGE				5 STAGE			6 STAGE					
	SD53	SD63	SD73	SD83	SD93		SD64	SD74	SD84	SD94		SD75	SD85	SD95		SD86	SD96
A	5 ³ / ₄	6 ³ / ₄	8	9 ¹ / ₈	10 ¹³ / ₁₆	A	6 ³ / ₄	8	9 ¹ / ₈	10 ¹³ / ₁₆	A	8	9 ¹ / ₈	10 ¹³ / ₁₆	A	9 ¹ / ₈	10 ¹³ / ₁₆
B	6 ³ / ₈	7 ³ / ₈	8 ⁵ / ₈	9 ⁷ / ₈	11 ³ / ₄	B	7 ³ / ₈	8 ⁵ / ₈	9 ⁷ / ₈	11 ³ / ₄	B	8 ⁵ / ₈	9 ⁷ / ₈	11 ³ / ₄	B	9 ⁷ / ₈	11 ³ / ₄
C	4 ³ / ₄	5 ³ / ₄	6 ³ / ₄	7 ⁷ / ₈	9 ³ / ₈	C	5 ³ / ₄	6 ³ / ₄	7 ⁷ / ₈	9 ³ / ₈	C	6 ³ / ₄	7 ⁷ / ₈	9 ³ / ₈	C	7 ⁷ / ₈	9 ³ / ₈
D	3 ³ / ₄	4 ³ / ₄	5 ³ / ₄	6 ³ / ₄	7 ⁷ / ₈	D	4 ³ / ₄	5 ³ / ₄	6 ³ / ₄	7 ⁷ / ₈	D	5 ³ / ₄	6 ³ / ₄	7 ⁷ / ₈	D	6 ³ / ₄	7 ⁷ / ₈
E	2 ³ / ₄	3 ³ / ₄	4 ³ / ₄	5 ³ / ₄	6 ³ / ₄	E	3 ³ / ₄	4 ³ / ₄	5 ³ / ₄	6 ³ / ₄	E	4 ³ / ₄	5 ³ / ₄	6 ³ / ₄	E	5 ³ / ₄	6 ³ / ₄
F						F	2 ³ / ₄	3 ³ / ₄	4 ³ / ₄	5 ³ / ₄	F	3 ³ / ₄	4 ³ / ₄	5 ³ / ₄	F	4 ³ / ₄	5 ³ / ₄
G						G					G	2 ³ / ₄	3 ³ / ₄	4 ³ / ₄	G	3 ³ / ₄	4 ³ / ₄
H						H					H				H	2 ³ / ₄	3 ³ / ₄
I _E	3/4	1	1	1 ¹ / ₄	1 ¹ / ₄	I _E	3/4	1	1	1 ¹ / ₄	I _E	3/4	1	1	I _E	3/4	1
I _R	1/2	3/4	3/4	1	1	I _R	1/2	3/4	3/4	1	I _R	1/2	3/4	3/4	I _R	1/2	3/4
J	1 ⁵ / ₈	2 ¹ / ₈	2 ¹ / ₈	2 ⁵ / ₈	2 ⁵ / ₈	J	1 ⁵ / ₈	2 ¹ / ₈	2 ¹ / ₈	2 ⁵ / ₈	J	1 ⁵ / ₈	2 ¹ / ₈	2 ¹ / ₈	J	1 ⁵ / ₈	2 ¹ / ₈
	215	220	259	289	403		263	289	314	425		350	370	465		T.B.D.	T.B.D.
	146	150	175	194	268		191	209	226	304		259	272	335		T.B.D.	T.B.D.
X	14.00	14.75	14.75	15.75	15.88	X	15.25	15.75	16.25	16.88	X	16.25	17.25	17.88	X	17.75	18.38
L _C	$\frac{\text{Stroke}}{3} + X$ O.L. = 6" up to 120" stroke					L _C	$\frac{\text{Stroke}}{4} + X$ O.L. = 6" up to 140" stroke				L _C	$\frac{\text{Stroke}}{5} + X$ O.L. = 6" up to 140" stroke			L _C	$\frac{\text{Stroke}}{6} + X$ O.L. = 6" up to 150" stroke	
X ₁	$\frac{\text{Stroke} - 120}{5}$ (To next largest whole number)					X ₁	$\frac{\text{Stroke} - 140}{6}$ (To next largest whole number)				X ₁	$\frac{\text{Stroke} - 140}{8}$ (To next largest whole number)			X ₁	$\frac{\text{Stroke} - 150}{10}$ (To next largest whole number)	
L _C	$\frac{\text{Stroke}}{3} + X + X_1$ O.L. = 6" + X ₁ 120" stroke to max.					L _C	$\frac{\text{Stroke}}{4} + X + X_1$ O.L. = 6" + X ₁ 140" stroke to max.				L _C	$\frac{\text{Stroke}}{5} + X + X_1$ O.L. = 6" + X ₁ 140" to 210" stroke			L _C	$\frac{\text{Stroke}}{6} + X + X_1$ O.L. = 6" + X ₁ 150" to 250" stroke	
X ₂	Not Required					X ₂					X ₂	$\frac{\text{Stroke} - 210}{3.5}$ (To next largest whole number)			X ₂	Check with Engineering	
L _C	Not Required					L _C					L _C	$\frac{\text{Stroke}}{5} + X + X_2 + 9$ O.L. = 15" + X ₂ 211" stroke to max.			L _C	Check with Engineering	

Genuine Replacement Service Parts

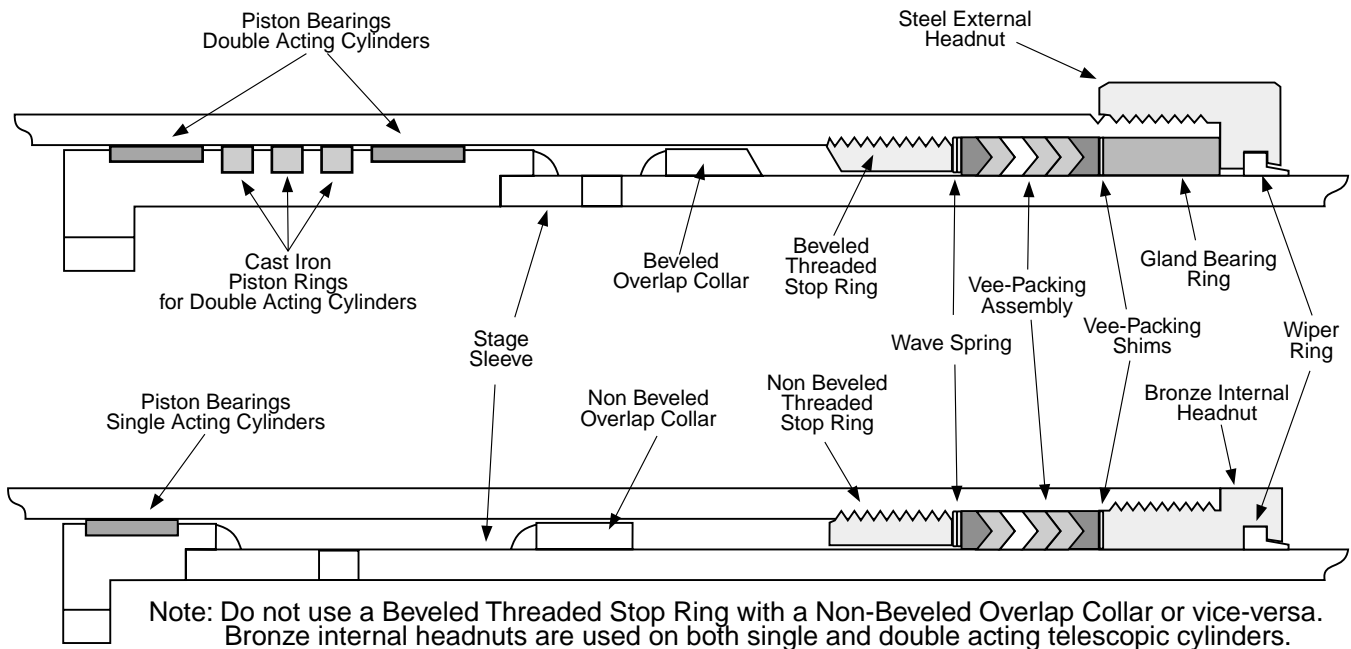

Following are service parts used on **STANDARD DESIGN COMMERCIAL** cylinders

Note: Commercial Hydraulics manufactures many different types and designs of cylinders. If you are not sure of service parts required please refer to the Cylinder Assembly print.

Description	2.75" Stage	3.75" Stage	4.75" Stage	5.75" Stage	6.75" Stage	7.905" Stage	9.375" Stage
Vee-Packing Assembly with Shims	375-9009-017 AJ3009-27	375-9009-034 AJ3009-37	375-9009-018 AJ3009-47	375-9009-019 AJ3009-57	375-9009-020 AJ3009-67	375-9009-021 AJ3009-79	375-9009-022 AJ3009-93
Wiper Ring	391-3882-061 Y3026-27	391-3882-053 Y3026-37	391-3882-054 Y3026-47	391-3882-055 Y3026-57	391-3882-056 Y3026-67	391-3882-057 Y3026-79	391-3882-058 Y3026-93
Gland Bearing Glass Filled Nylon	391-2682-001 J1003-1-1	391-2682-002 J1003-1-2	391-2682-003 J1003-1-3	391-2682-004 J1003-1-4	391-2682-005 J1003-1-5	391-2682-006 J1003-1-6	391-2682-007 J1003-1-7
Gland Bearing Bronze	375-9003-064 AH1003-27	375-9003-044 AH1003-37	375-9003-045 AH1003-47	375-9003-046 AH1003-57	375-9003-063 AH1003-67	375-9003-041 AH1003-79	375-9003-066 AH1003-93
Wave Spring	391-3581-320 P1327-27	391-3581-300 P1327-37	391-3581-301 P1327-47	391-3581-302 P1327-57	391-3581-303 P1327-67	391-3581-304 P1327-79	391-3581-310 P1327-93
Threaded Stop Non-Beveled	375-4020-001 F4020	375-3020-002 F3020	375-6020-002 F6020	375-5020-001 F5020	375-7020-001 F7020	375-8020-001 F8020	375-9020-001 F9020
Threaded Stop Beveled	375-3020-110 AG3020-1-27	375-3020-111 AG3020-1-37	375-3020-112 AG3020-1-47	375-3020-113 AG3020-1-57	375-3020-114 AG3020-1-67	375-3020-120 AG3020-2-79	375-3020-119 AG3020-2-93
Piston Bearing Glass Filled Nylon	391-2684-123 U3023-32	391-2684-069 U3023-42	391-2684-070 U3023-52	391-2684-071 U3023-62	391-2684-072 U3023-72	391-2684-073 U3023-84	391-2684-098 U3023-98
Piston Bearing Bronze	N/A	375-9023-079 AM3023-42	375-9023-038 AM3023-52	375-9023-039 AM3023-62	375-9023-040 AM3023-72	375-9023-041 AM3023-84	375-9023-042 AM3023-98
Cast Iron Piston Ring	391-2683-010 X78-3.25-1	391-2683-014 X78-4.25	391-2683-019 X78-5.25	391-2683-024 X78-6.25	391-2683-029 X78-7.25	391-2683-034 X78-8.437	391-2683-042 X78-9.88
Steel External Headnut	391-1470-162 YA3011-27	391-1470-163 YA3011-37	391-1470-164 YA3011-47	391-1470-165 YA3011-57	391-1470-166 YA3011-67	391-1470-167 YA3011-79	391-1470-177 YA3011-93
Bronze Internal Headnut	391-1470-079 MA3011-27	391-1470-070 MA3011-37	391-1470-071 MA3011-47	391-1470-072 MA3011-57	391-1470-073 MA3011-67	391-1470-074 MA3011-79	391-1470-075 MA3011-93

Repair Kits

For Standard Commercial Hydraulics Single-acting, Dump Body Cylinders.

Commercial's genuine replacement parts are available in kits to rebuild or repack our dump body cylinders. These parts are the same as originally installed.

As with all hydraulic repairs, be sure your shop is properly equipped and that the work area is clean.

Rebuilding kits consist of:

- | | |
|------------------------|--------------------|
| 1. Wiper Rings | 5. Piston Bearings |
| 2. Packing Assemblies | 6. Set Screws |
| 3. Gland Bearing Rings | 7. Nylon Balls |
| 4. Wave Springs | |

Repacking kits consist of:

- | | |
|----------------|-----------------------|
| 1. Wiper Rings | 2. Packing Assemblies |
|----------------|-----------------------|

Ordering Information

Please order by part number

Cylinder Model	Rebuild Kit Number		Repack Kit Number	
S53 Series	A300-253	375-1804-017	A300-11	391-1804-020
S62 Series	A300-256	375-1804-020	A300-262	375-1804-026
S63 Series	A300-254	375-1804-018	A300-104	391-1804-109
S64 Series	A300-257	375-1804-021	A300-230	391-1804-237
S73 Series	A300-255	375-1804-019	A300-238	375-1804-002
S74 Series	A300-258	375-1804-022	A300-239	375-1804-003
S84 Series	A300-259	375-1804-023	A300-49	391-1804-054
S85 Series	A300-260	375-1804-024	A300-22	391-1804-060
S95 Series	A300-261	375-1804-025	A300-240	375-1804-004

Cylinder Packing Installation

Remove shims from packing set and measure packing height under finger pressure. Add one shim for each 1/32" that the packing measures under 1-1/8". Measure depth to top of stop ring from top of tube. This dimension should be 2-1/4", however, it may vary slightly due to seating of the stop ring. Add one shim to the packing set for every 1/32" that this dimension measures over 2-1/4" or remove one shim from the packing set for every 1/32" that this dimension measures under 2-1/4". Install wave spring with gap edge against top of the cylinder stop ring. Soak packing in hydraulic oil for a few minutes. (Check bottom adaptor. Only hard type can be used with the wave spring). Install packing, one ring at a time, in the proper sequence as shown in the sketch. Note: The soft, low pressure ring must be in the second position from the pressure side. Installed packing height need not be checked because wave spring will vary this

dimension. Installation of bearing and packing nut will compress wave spring for proper packing pre-load. Pull down tight against tube.

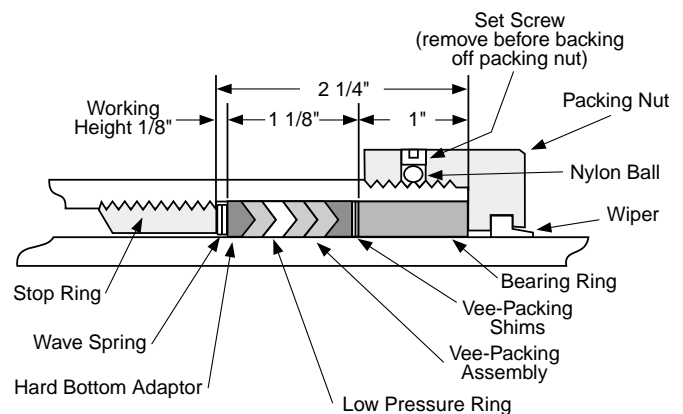

Hydraulic Cylinder Required Service Tools

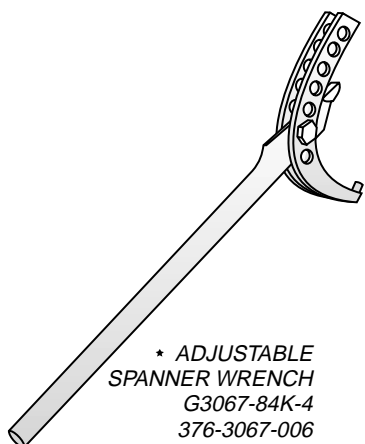

* ADJUSTABLE
SPANNER WRENCH
G3067-84K-4
376-3067-006

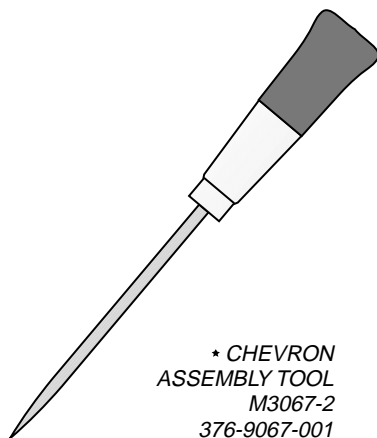

* CHEVRON
ASSEMBLY TOOL
M3067-2
376-9067-001

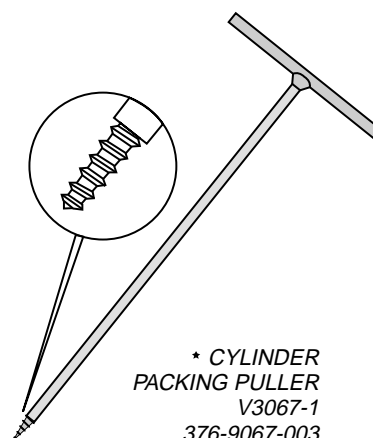

* CYLINDER
PACKING PULLER
V3067-1
376-9067-003

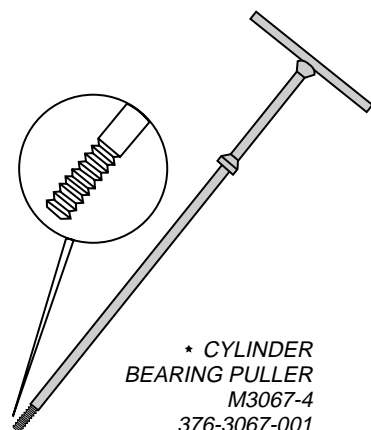

* CYLINDER
BEARING PULLER
M3067-4
376-3067-001



* STRAP WRENCH
P3067
376-9067-002

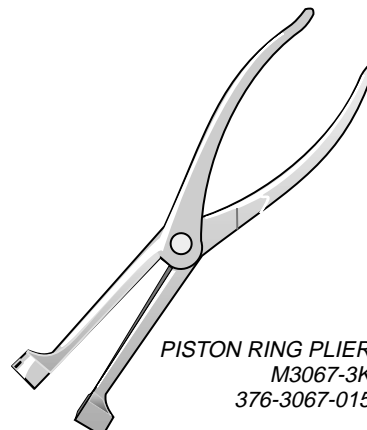

PISTON RING PLIER
M3067-3K
376-3067-015

Tools Required

Proper tools make the job of servicing cylinders easier and faster and reduce the possibility of damaging the finely machined surfaces. We recommend that you have the tools shown on this page prior to attempting service on Commercial telescopic cylinders. Tools with an * are required for all cylinders regardless of size. Lifting rings and stop ring wrenches must be ordered to fit the specific sleeve in the cylinder.

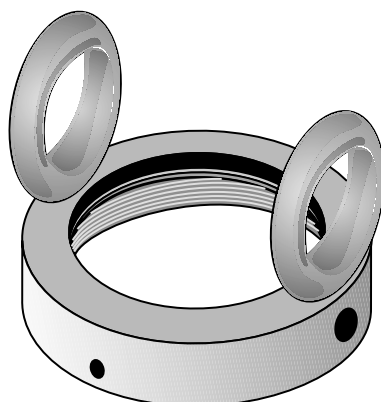

Lifting Ring
BC3067 Series

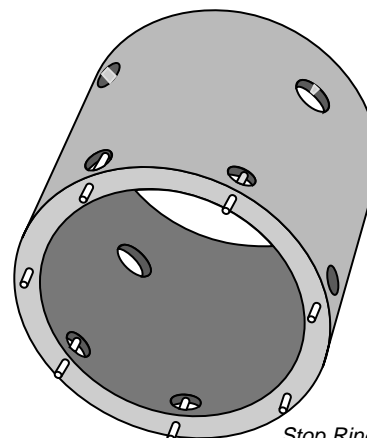

Stop Ring Wrench
BA3067 Series

Sleeve or Main O.D.	Eng #	Part Number
3 3/4"	BC3067-1,	376-3067-008
4 3/4"	BC3067-2,	376-3067-009
5 3/4"	BC3067-3,	376-3067-010
6 3/4"	BC3067-4,	376-3067-011
7 7/8"	BC3067-5,	376-3067-012
9 3/8"	BC3067-6,	376-3067-013
11 1/8"	BC3067-7,	376-3067-014

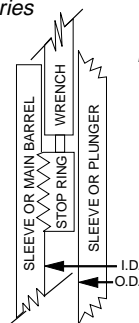

Sleeve or Main I.D.	Sleeve or Plunger O.D.	Eng #	Part Number
3 1/4"	2 3/4"	BA3067-1,	376-6067-047
4 1/4"	3 3/4"	BA3067-2,	376-6067-048
5 1/4"	4 3/4"	BA3067-3,	376-6067-049
6 1/4"	5 3/4"	BA3067-4,	376-6067-050
7 1/4"	6 3/4"	BA3067-5,	376-6067-051
8 7/16"	7 7/8"	BA3067-6,	376-6067-052
9 7/8"	9 3/8"	BA3067-7,	376-6067-053

Normal Maintenance Items

Packing, wipers and bushings are considered normal maintenance or service items. These items are subject to contamination from external and internal foreign materials, many of which are abrasive in nature, causing abnormal wear or damage to the parts, to the extent that replacements are required.

WARNING!!

Before working on a telescopic cylinder mounted on a truck or trailer unit, use supports or holding devices that will absolutely prevent the body from accidentally lowering. Place control valve in the "Lower" position to assure that all pressure has been relieved from the cylinder.

Because of our self-compensating Packing design, Standard Commercial Hydraulics Cylinders require no packing adjustment. For Commercial Packing Assembly Installation Procedure see Service Repair Kit Page.

Procedure for Adjusting Telescopic Cylinder Head Nuts. (For Cylinder designs using no Wave Springs and/or no U-Seals)

1. Loosen set screw (or set screws) in head nut that holds in packing of leaking stage.
2. Lightly tap head nut around circumference with a hammer.
3. Back head nut off 1/2 to 1 full turn using a spanner or chain wrench.
(Note: If stage rotates when head nut is turned, hold stage with a strap wrench.)
4. Cycle cylinder 2 to 3 times to reset chevron vee packing.
5. Retighten head nut approximately 1/2 turn further than it was when it was loosened.
6. Tighten set screws.

Procedure for Mis-Staging or Mis-Sequencing Cylinder.

1. Loosen set screws in head nut that holds in packing which fits over stage that is sticking.
2. Lightly tap head nut around circumference with a hammer.
3. Back head nut off 1/2 turn using a spanner or chain wrench.
4. Cycle cylinder, if cylinder still mis-stages, back head nut off another 1/2 turn.
5. Cycle cylinder, if cylinder still mis-stages, tighten the head nut of the next stage that is extending.
6. Tighten set screws.

Bleeding Air from Single-Acting Telescopic Cylinders.

For smooth operation of these cylinders, it is advisable to bleed the air from the cylinder weekly.

Manual bleeding is accomplished by:

1. Empty the dump body of any material.
2. Remove the cover plate from the dog house of the dump body to access the bleeder valve.
3. Fully extend the cylinder, raising the EMPTY dump bed.
4. Lower the dump to within 1 foot from resting on the frame.
5. With the fingers, turn the bleeder valve in a counterclockwise direction. This opens the valve and allows the air to escape from the cylinder.
6. When a steady stream of oil comes from the bleeder, turn the valve in a clockwise direction until it is closed.

**If these procedures fail to correct the problem, please contact an
Authorized Service Center for Instructions.**

Standard Test Procedure for Hydraulic Cylinders

1) Function Test

Once the Cylinder is placed on the test stand and hydraulic lines attached, the cylinder will be cycled its full stroke a minimum of three (3) full cycles.

The cylinder will be rejected if it functions erratically. Erratic function is excessive chatter, slapstrick, stalling and uncorrectable misstaging.

2) Proof Pressure Test

After the function test is performed the cylinder will be extended fully and pressure held for a minimum of thirty (30) seconds. This pressure will be 2500 psi or a pressure indicated on the assembly print. The cylinder will be rejected for external leakage or structural deformation. If the cylinder is double acting, it will be fully retracted and pressure held for a minimum of thirty (30) seconds. The pressure will be 2500 psi or a pressure indicated on the assembly print. The cylinder will be rejected for external leakage or structural deformation.

3) Internal Bypass Test

This test will be performed on all double acting cylinders and can be done in conjunction with the Proof Pressure Test. The cylinder will be fully extended and pressure held at 2500 psi. The retract line will be removed and piston seal bypass will be determined by the flow out of this cylinder port. Excessive bypass will be a cause for cylinder rejection. The cylinder will be fully retracted and pressure held at 2500 psi. The extend line will be removed and the piston bypass will be determined by the flow out of this cylinder port. The cylinder will be rejected for excessive flow. When making this test the hydraulic line should be completely removed from the cylinder port, and the open line from the valve should be plugged or capped since a slight back pressure in the tank return line would spill oil from the line if not plugged.

Pass/Fail criteria if not noted on Assembly drawing is as follows:

Cast Iron Rings Normal Maximum leakage 1 GPM.

Bypass = 1/2 cubic inch per inch of bore diameter per minute.

Extend bypass would be 1/2 cubic inch per inch of plunger piston ring OD per minute.

Retract bypass would be 1/2 cubic inch per inch of piston ring OD per minute of each stage added together.

Example SD73 Series;

Extend bypass; $1/2 \times 5.25 = 2.62$ cubic in / min.

Retract bypass; $(1/2 \times 7.25) + (1/2 \times 6.25) + (1/2 \times 5.25) = 9.38$ cubic in / min.

Soft Seals Maximum leakage 5 drops per minute.

Please Note

Before Installing a New Cylinder in an old application

Has the problem been corrected that caused the original cylinder to fail?

Is the hydraulic fluid clean of all contamination, water, and entrapped air?

Are the hydraulic system relief valve pressures set and operating properly?

Is the mechanism or unit the cylinder is operating in good mechanical condition?

Hydraulic Oil Recommendations

All cylinder parts, with the exception of a few items, are lubricated by the hydraulic oil in the circuit. Particular attention must be paid to keep the oil in the circuit clean. Whenever there is a hydraulic component failure (cylinder, pump, valve), and there is a reason to feel that metal particles may be in the system, the oil must be drained, the entire system flushed clean, and any filter screens thoroughly cleaned or replaced. New oil should be supplied for the entire system. Oil suitable and recommended for use in circuits involving Commercial cylinders should meet the following specifications:

***These suggestions are intended as a guide only.
Obtain your final oil recommendations from your oil supplier.***

Viscosity Recommendations:

Optimum operating viscosity is considered to be about 100 SSU.

- * 50 SSU minimum @ operating temperature
7500 SSU maximum @ starting temperature
- * 150 to 225 SSU @ 100° F. (37.8° C.) (generally)
44 to 48 SSU @ 210° F. (98.9° C.) (generally)

Other Desirable Properties:

Viscosity Index: 90 minimum
Aniline point: 175 minimum

Additives Usually Recommended:

Rust and Oxidation (R & O) Inhibitors
Foam Depressant

Other Desirable Characteristics:

Stability of physical and chemical characteristics.
High demulsibility (low emulsibility) for separation of water, air and contaminants.
Resistant to the formation of gums, sludges, acids, tars and varnishes.
High lubricity and film strength.

General Recommendations:

A good quality hydraulic oil conforming to the characteristics listed above is essential to the satisfactory performance and long life of any hydraulic system.

Oil should be changed on regular schedules in accordance with the manufactures recommendations and the system periodically flushed.

Oil operating temperature should not exceed 200° F. (93° C.) with a maximum of 180° F. (82° C.) generally recommended. 120° F. to 140° F. (50° C. to 60° C.) is generally considered optimum. High temperatures result in rapid oil deterioration and may point out a need for an oil cooler or a larger reservoir. The nearer to optimum temperature, the longer the service life of the oil and the hydraulic components.

Reservoir size should be large enough to hold and cool all the fluid a system will need, yet it should not be wastefully large. Minimum required capacity can vary anywhere between 1 and 3 times pump output. The reservoir must be able to hold all of the fluid displaced by retracted cylinders when the system is not operating, yet provide space for expansion and foaming.

Oil poured into the reservoir should pass through a 100 mesh screen. Pour only clean oil from clean containers into the reservoir.

Never use Crank Case Drainings, Kerosene, Fuel Oil, or any Non-Lubricating Fluid, such as Water.

Approximate SSU at . . .

Oil Grade	100° F. (37.8° C.)	210° F. (98.9° C.)
SAE 10	150	43
SAE 20	330	51

Normal Temperatures:

0° F. (-18° C.) to 100° F. (37.8° C.) ambient
100° F. (37.8° C.) to 180° F. (82.2° C.)
system

Be sure the oil you use is recommended for the temperature you expect to encounter.

Front Mount Dump Body Stroke & Lifting Calculations

Note: This guide is for use to determine approximate stroke and lifting requirements for a Front Mount Dump Body, they should not be used for Frameless Type Trailers, Underbody, Telescopic Farm (slant forward or rearward), or Scissor Type Hoists. Final dimensions and calculations should be determined by an engineering drawing.

Formula for Calculating Initial Required Cylinder Force to Lift a Load

$$\frac{\text{Load (lbs)} \times "A"}{"B"} = \text{Initial required cylinder force}$$

Example

$$\frac{50,000\# \times 85"}{166"} = 25,603\# \text{ of force to start the lift}$$

Commercial Telescopic Lifting Capacities

Stage O.D. inches	System operating pressure			
	800 psi	1000 psi	1500 psi	2000 psi
2.75"	4752	5940	8909	11879
3.75"	8836	11045	16567	22089
4.75"	14176	17721	26581	35441
5.75"	20774	25967	38951	51935
6.75"	28628	35785	53677	71570
7.90"	39213	49017	73525	98034
9.37"	55165	68956	103434	137911

Note: For a good design, initial pressure should not exceed 800 psi at start of lift. Effective force (capacity) is only that of the sleeve / stage which is moving and will decrease as cylinder changes to the next moving sleeve. The effective force will also be reduced if the

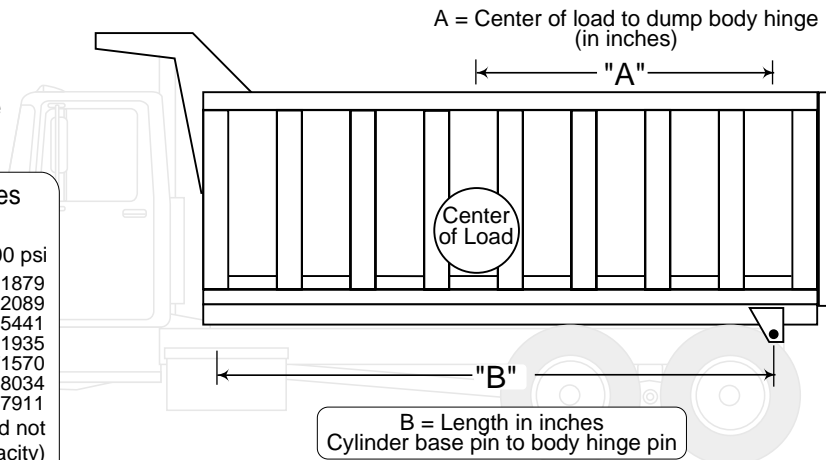

Formula for Calculating the Required Cylinder Stroke for a Dump Angle

$$"B" \times "D" = \text{Approximate Stroke}$$

Example

$$166" (B) \times .845 (D) = 140" \text{ Stroke}$$

Dump Angle Multipliers

"D" = Dump Angle

.715	=	42 deg
.733	=	43 deg
.750	=	44 deg
.765	=	45 deg
.780	=	46 deg
.797	=	47 deg
.813	=	48 deg
.830	=	49 deg
.845	=	50 deg
.861	=	51 deg
.877	=	52 deg
.892	=	53 deg
.903	=	54 deg
.923	=	55 deg
.939	=	56 deg
.954	=	57 deg

Normal minimum dump angle is 45 degree
Normal maximum dump angle is 57 degree

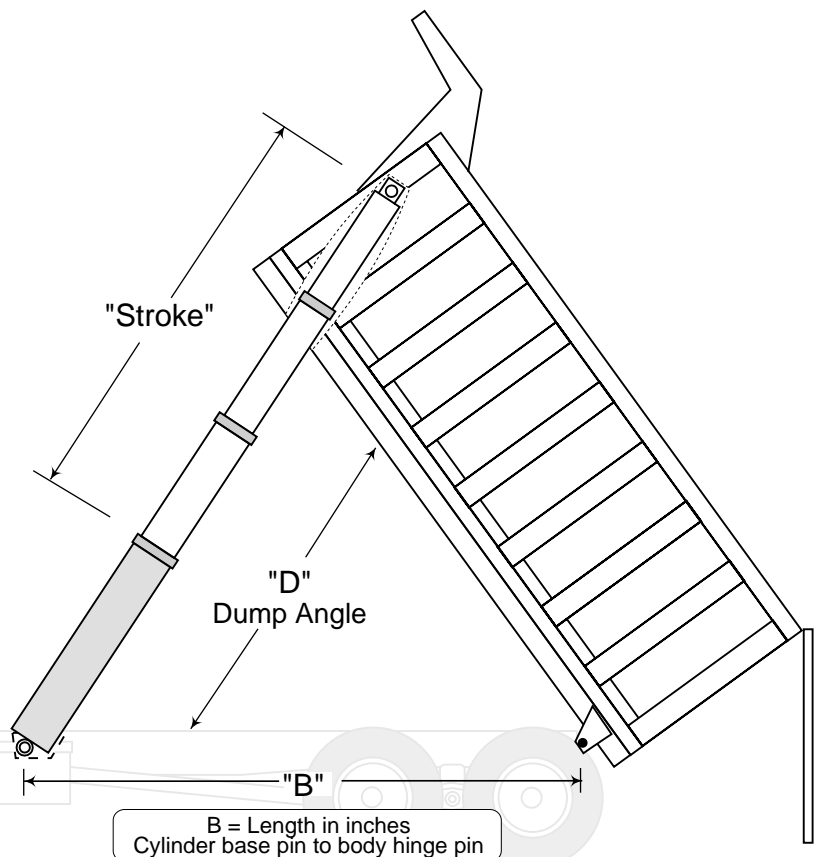

Commodities & Materials Approximate Weights

Approximate Weights of Materials

Material	lbs. / cu. yd.	tons / cu. yd.	Material	lbs. / cu. yd.	tons / cu. yd.
Andesite stone	4887	2.44	Earth & sand, wet	3240	1.62
Ashes	1080	0.52	Fire Brick	3915	1.95
Asphalt	2700	1.35	Fire Clay	3510	1.75
Asphaltum	2349	1.17	Garbage	1150	0.57
Basalt rock	4887	2.44	Gravel, dry	2970	1.48
Brick, soft clay	2718	1.35	Gravel, out of water	1620	0.81
Brick, hard clay	3397	1.69	Granite	4536	2.26
Brick, pressed	3806	1.9	Lime, quick, loose	1431	0.71
Brick, paving	4246	2.12	Lime, quick, shaken	1485	0.70
Block, paving	3694	1.84	Limestone, solid	4536	2.26
Bluestone	2970	1.48	Limestone, loose	2592	1.29
Cement, natural	1512	0.75	Marble, solid	4455	2.22
Cement, Portland	2430	1.21	Marble, loose	2592	1.29
Cement, Portland, set	4941	2.47	Mortar, set	2781	1.39
Cement, Rosendale	1863	0.93	Mud, dry	2430	1.21
Cinders	1080	0.54	Mud, packed	3105	1.55
Clay, dry	1701	0.85	Mud, wet	2916	1.45
Clay, wet	2970	1.48	Pitch	1863	0.93
Clay & gravel, dry	2700	1.35	Plaster of Paris	2646	1.32
Coal, anthracite	1536	0.76	Powder, blasting	1682	0.84
Coal, bituminous	1275	0.64	Quartz	4374	2.18
Coke	837	0.42	Rubbish	199.8	0.09
Concrete, cinders	2970	1.48	Sand, dry, loose	2619	1.30
Concrete, gravel	4104	2.05	Sand, wet	3186	1.59
Concrete, limestone	4050	2.02	Sandstone	4023	2.01
Concrete, sandstone	3915	1.95	Slag, bank	1890	0.94
Concrete, trap rock	4185	2.09	Slag, screenings	2700	1.35
Crushed stone	2700	1.35	Slag, machine	2592	1.29
Earth, dry, loose	1890	0.94	Slag, sand	1485	0.74
Earth, damp, loose	2106	1.05	Shale	4374	2.18
Earth, damp packed	2592	1.29	Slate	4725	2.31
Earth & gravel, dry	2700	1.35	Tar	1674	0.83
Earth & gravel, wet	3240	1.62	Tile	2970	1.43
Earth & sand, dry	2709	1.35	Trap stone	5849	2.52

Steel & Aluminum Gauge, Thickness and Weight

Steel

3/8"	0.375	15.320 lbs. per sq. ft.
1/4" (approx. 3 Ga.)	0.250	10.200 lbs. per sq. ft.
3/16" (approx. 7 Ga.)	0.188	7.650 lbs. per sq. ft.
8 Ga.	0.164	6.875 lbs. per sq. ft.
9 Ga.	0.149	6.250 lbs. per sq. ft.
10 Ga.	0.134	5.625 lbs. per sq. ft.
11 Ga.	0.120	5.000 lbs. per sq. ft.
12 Ga.	0.105	4.375 lbs. per sq. ft.
13 Ga.	0.090	3.750 lbs. per sq. ft.
14 Ga.	0.075	3.125 lbs. per sq. ft.

Aluminum

3/8"	0.375	5.18 lbs. per sq. ft.
1/4"	0.250	3.53 lbs. per sq. ft.
3/16"	0.188	2.65 lbs. per sq. ft.
5/32"	0.156	2.25 lbs. per sq. ft.

Single Acting Telescopic Cylinder Operation

Extending

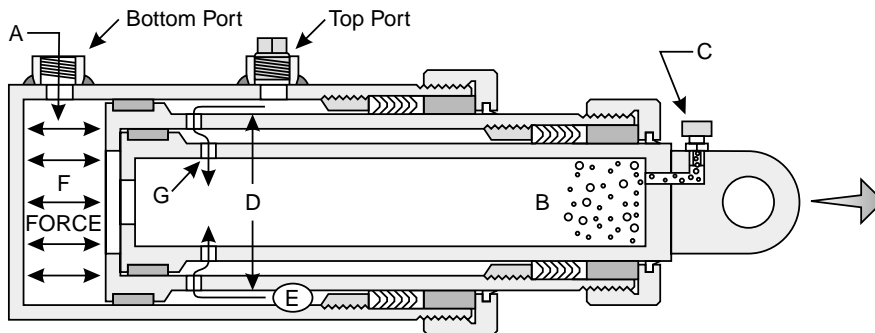

To Extend:

High pressure oil from the pump is directed by the control valve through the port (A) to fill the cylinder. Any air in the system is trapped in the end of the cylinder (B) and may be bled off through the bleeder valve (C).

Generally, bleeding is only necessary on initial start up or if air has been allowed to enter the system (Note: the bleeder valve must be located at the highest part of the cylinder).

Oil pushes on the bottom of the sleeve or plunger forcing (F) it to move out. The outside diameter or sealing area of the moving sleeve or plunger (D) determines the effective area.

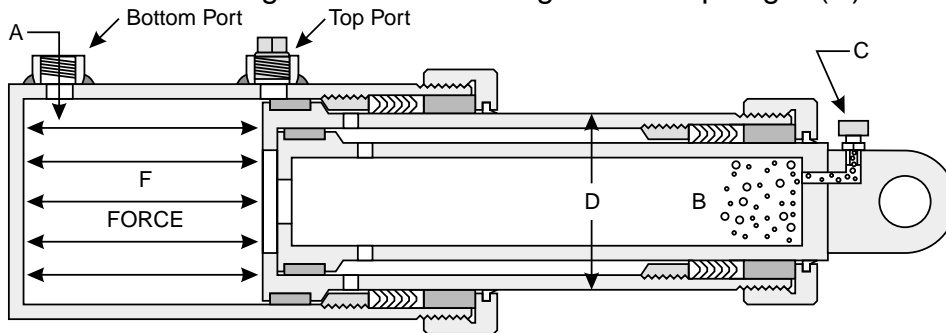

As the sleeve or plunger moves out, the oil trapped between (E) the sleeve or plunger wall is released through transfer holes (G) which are drilled in the sleeve or plunger.

Under normal operating conditions the largest diameter moving sleeve extends first, then the next largest sleeve, etc.

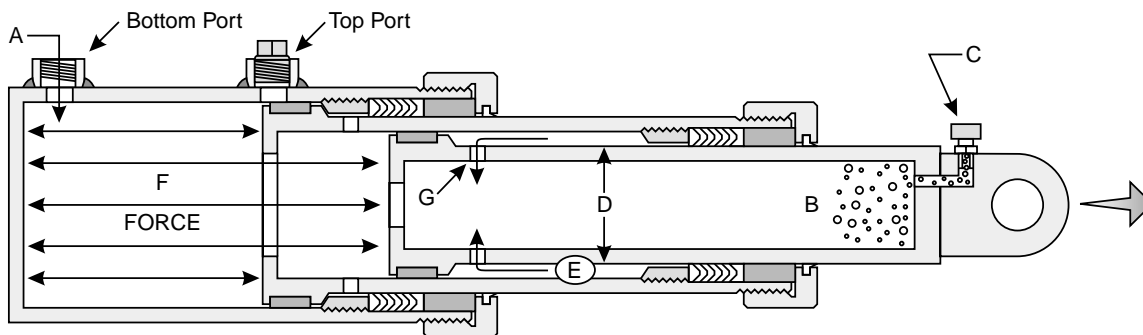

So at a given PSI (pressure) and GPM (gallons per min.) the cylinder will develop less force and increase in speed as it changes to the next moving stage.

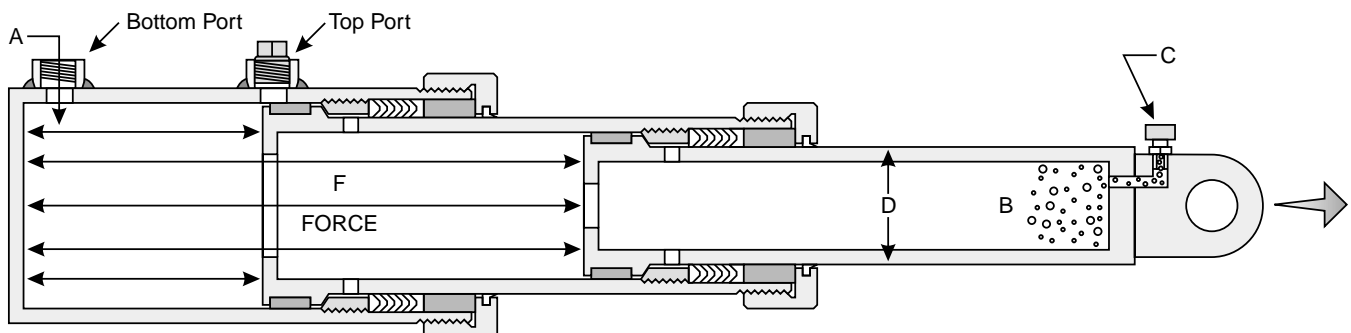

Single Acting Telescopic Cylinder Operation

Retracting

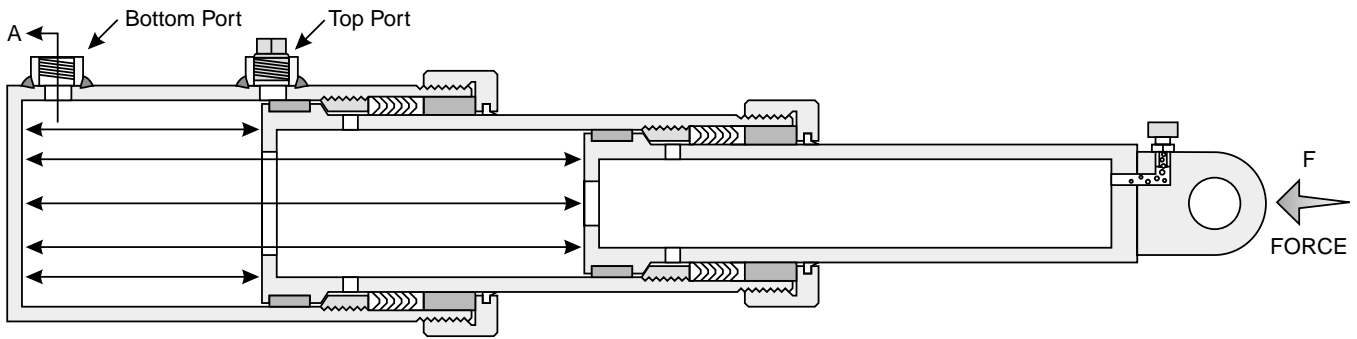

To Retract:

A single acting cylinder must be retracted by gravity or mechanical means (F).

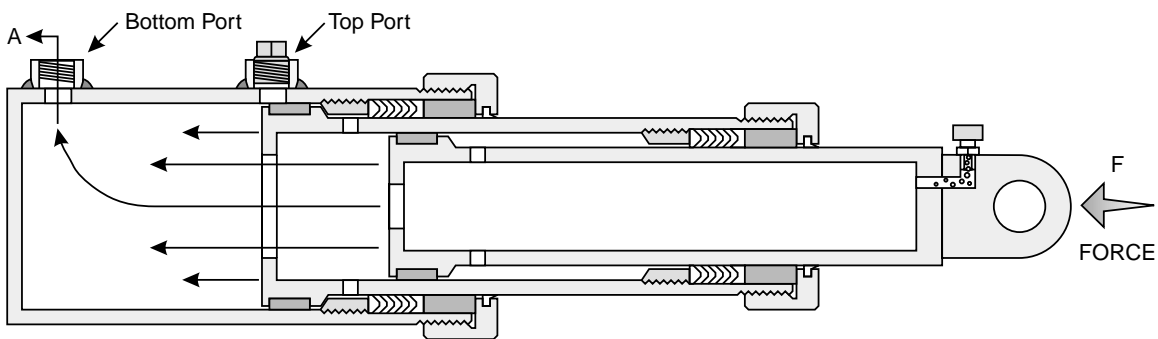

Under normal operating conditions the plunger or smallest diameter sleeve is pushed closed first, forcing oil out through port (A), then the next smallest, etc.

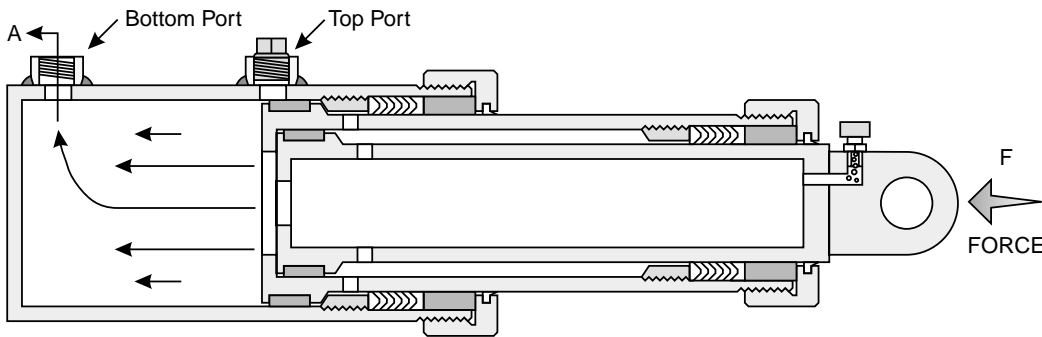

Note: If the top port is used, the speed of the cylinder may be reduced because of the oil flow restriction as the oil passes thru the transfer holes (G).

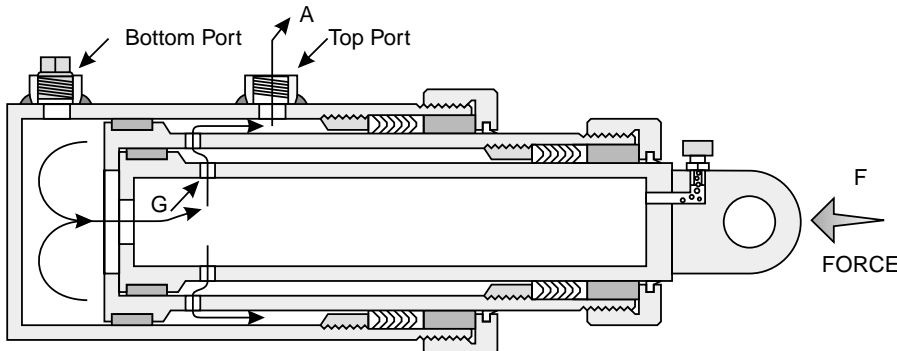

Equip your vehicle with
 **Commercial Hydraulics**
the world's best hydraulic cylinders

Single-Acting Telescopic Dump Cylinders

WARNING!! Telescopic cylinders commonly installed on dumping vehicles are devices intended to provide only a lifting force. The cylinder is not a structural member, and is not designed for, nor intended to provide stability to the dumping vehicle. The cylinder can bend, buldge or separate causing the dump body to drop suddenly, resulting in serious personal injury or property damage, if the following warnings are not observed.

Cylinders are not to be used as a stabilizer on a dump body or dump trailer. The cylinder is strictly a lifting device and is not a structural member of the dumping unit.

The cylinder should float in the pin mountings. The cylinder should be installed with 1/8" to 3/16" of clearance between the pin and the pin hole if the mounting eye is wider than 5", or with 1/16" to 1/8" clearance if the mounting eye is less than 5" wide. There should be a clearance of 1/8" to 1/4" per side on eyes less than 5" wide and 1/4" to 1/2" clearance per side on eyes in excess of 5" wide. This is to allow the body to sway slightly while dumping, without putting a side load on the cylinder. The cylinder plunger or one of the sleeves should be extended a minimum of 1/4" when the dump body is in the down position. The cylinder end mounts should be lubricated regularly.

Cylinders cannot withstand side pressures from a dump unit leaning. A tractor trailer unit must be in a straight line when dumping, not jackknifed. All dump units must be on firm, level ground and not operated during heavy crosswinds. Failure to do so may cause the unit to upset.

Do not overload the dump unit. The load must be evenly distributed during loading and unloading.

Do not jerk or slingshot dump unit in an attempt to free a sticking or frozen load. Pulling forward (or backing up) and hitting the brakes, or lowering the body part way and then quickly engaging the valve in the "HOLD" or "RAISE" position will cause a tremendous pressure spike. This pressure spike may bulge or split one of the larger stages of the cylinder.

When lowering a load that is sticking, the dump unit must be feathered down slowly to avoid a high pressure build up in the cylinder.

Do not operate cylinder at pressures above factory recommended operating pressures (Normally 2,000 P.S.I unless otherwise approved).

The driver should stay at the controls during the entire dumping operation. If the body starts to lean to one side, the driver should immediately lower the body. It is important to feather the control valve into the hold position to avoid a pressure spike in the cylinder.

Do not operate cylinder with personnel or equipment alongside.

The dump unit must be lowered completely before moving unit.

Do not drive with P.T.O. or Hydraulic Pump engaged.

Hydraulic hoses should be inspected regularly and replaced if worn out or damaged.

Hydraulic oil should be inspected and or changed regularly and whenever a new cylinder is installed.

A damp to light film of oil on each plunger or stage of a telescopic cylinder indicates good cylinder operation. After many cycles of the cylinder, a small accumulation of oil may be noticed on the plungers or sleeves at the head nuts. This should not be mistaken for packing leakage.

Cylinder should be free of entrapped air. It is advisable to bleed air from cylinder weekly for a smooth operation.

Before working on a telescopic cylinder mounted on a truck or trailer unit, use supports or holding devices that will absolutely prevent the body from accidentally lowering. Place control valve in the "LOWER" position to assure that all pressure has been relieved from the cylinder.

8 Tips to Help Prevent End Dump Roll-Overs

1. Wind:

Do not attempt dumping operations in high gusty wind conditions. If possible, raise the dump body directly into the wind.

2. Terrain:

Uneven terrain, causing the trailer wheels to be 3 1/2 inches to 4 inches higher than the other side, puts the top of the body 12 inches to 14 inches off center when the cylinder is fully extended. On fresh fill, loaded trailer wheels may sink on one side, again setting up potential tipover. On road construction, the crown is also critical on spread application, as in dumping on a slope. A 4 inch plus, height differential of wheels on an axle 8 feet wide, is another rollover potential.

3. Hung Loads:

A hung load is commodity that does not discharge when a dump body is raised to an elevated position. This condition exists due to surface adhesion between the commodity and the interior of the dump body. To avoid a tipover due to a hung load, the driver should be warned by an observer or be aware of the material's moisture content, if this condition exists, immediately lower the dump body.

4. Humping:

Humping is a rapid acceleration / deceleration method used to loosen a hung load from a trailer. If the load is off center and the trailer is moved, a tipover may occur. Also, serious damage to the hoist may occur if an extreme humping motion is used to get a sticky load out of the body.

5. Jackknife:

A jackknife position of the tractor with the trailer is not recommended when dumping. In a jackknifed position, the upper coupler pivots on bearings, contributing nothing to dump stability. When the tractor and trailer are straight, the coupler bearings are normally 34 inches apart, assisting in stabilizing the dump.

6. Tires:

A blown tire or a severely underinflated tire can cause dump instability, when dumping. Always check tires visually for cuts or punctures by nails and metal. Make sure all tires are inflated properly. Proper tire inflation also improves wear and fuel economy.

7. Stay at the Controls:

An operator who fails to stay at the controls will never control the body when it starts to lean over for a tipover. If a problem exists, the body can be lowered and the operator can check and remedy any potential problems, then resume dumping the load.

8. Overloading:

Overloading is a very common occurrence that aggravates all the above conditions that cause tipovers.

Double Acting Telescopic Cylinder Operation

Extending

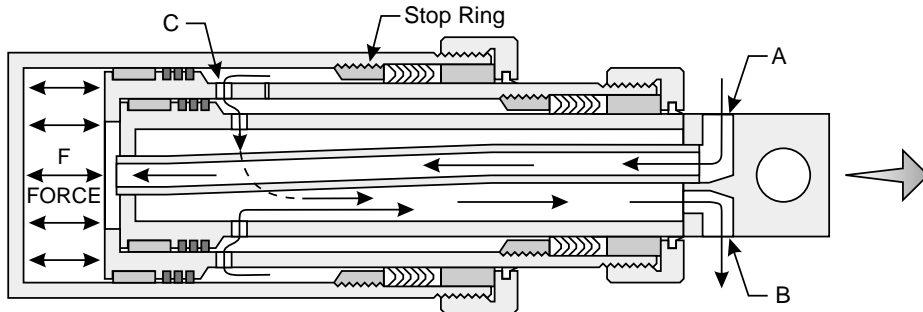

To Extend:

High pressure oil is directed by the control valve into port A. The oil passes through the transfer tube in the rod to the base of the cylinder.

The pressure acts on the effective area (area of the largest piston) and extends all stages to the first stop ring. The next stage then begins to extend.

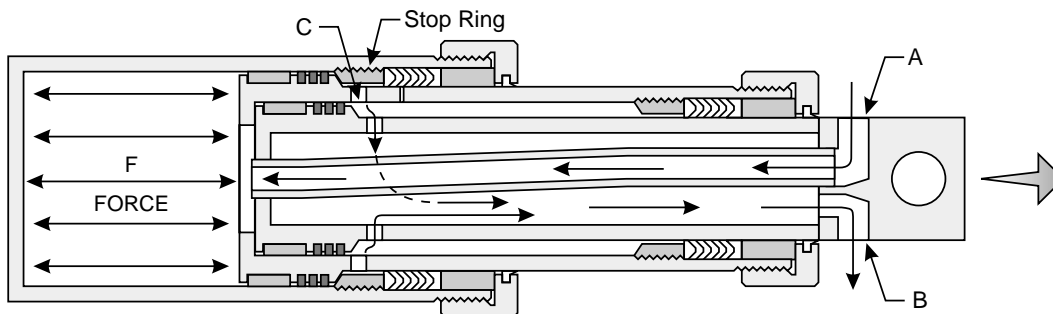

The effective area of each stage is figured from the inside diameter of the next largest stage. Each stage extends in its turn to the stop ring. So at a given PSI (pressure) and GPM (gallons per min.) the cylinder will develop less force and increase in speed as it changes to the next moving stage.

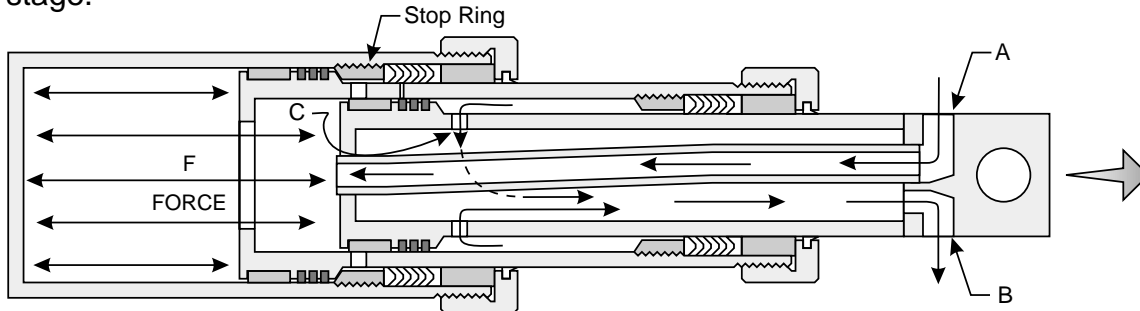

Oil trapped between the sleeves escapes through holes (C) in each sleeve and returns to the tank through port B.

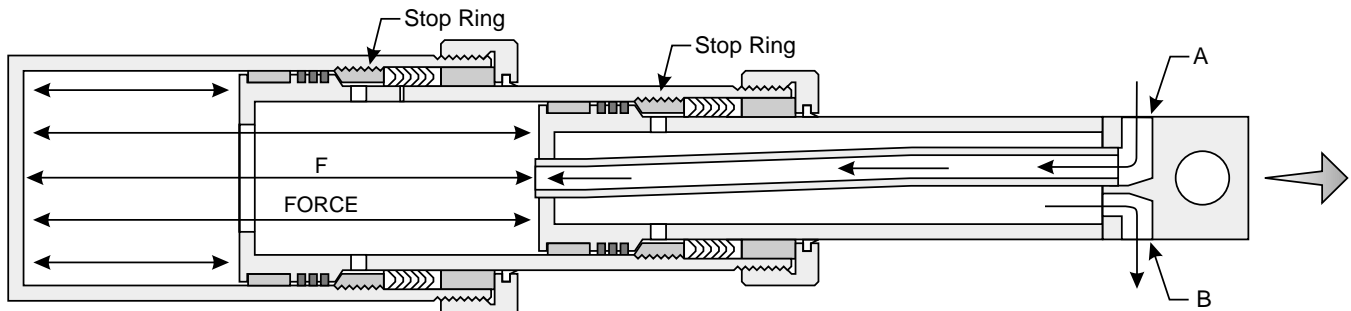

Double Acting Telescopic Cylinder Operation

Retracting

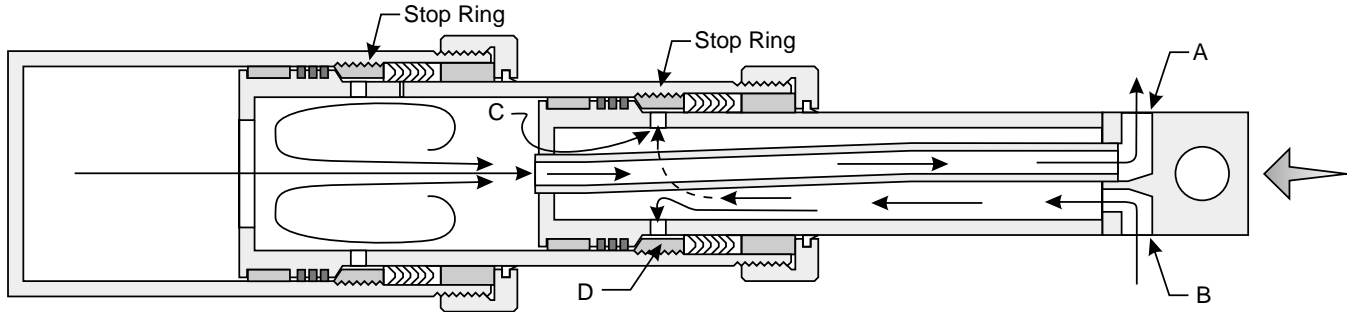

To Retract:

High pressure oil is directed by the control valve into port B. The pressure is applied to the effective area (D) of the plunger which retracts first. Each stage from the smallest to the largest

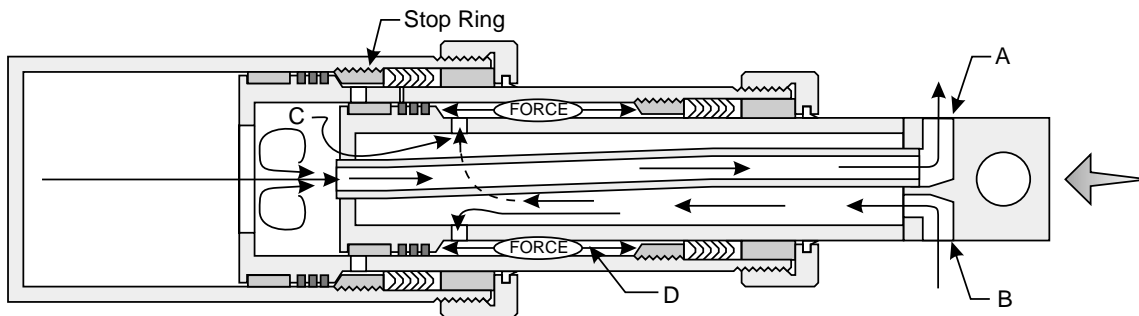

retracts in its turn, however, THE EFFECTIVE AREA FOR RETRACTING EACH STAGE IS THE AREA (D) OF THE PLUNGER.

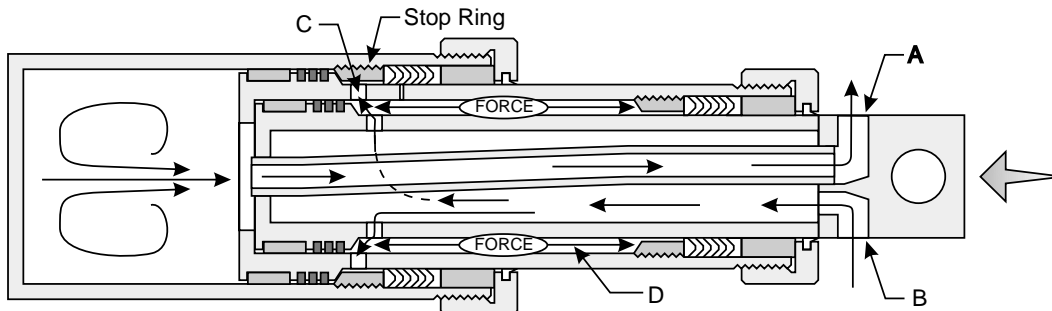

Oil inside the cylinder is forced out of port A. Because of the area differential, the flow into port B must be multiplied by this differential to determine the flow out of port A. It may be necessary to install a dump-to-tank valve to speed up the retracting cycle.

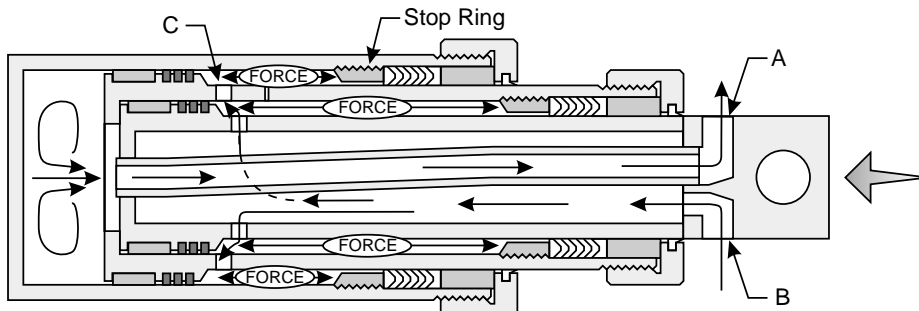

Equip your vehicle with
 **Commercial Hydraulics**
 the world's best hydraulic cylinders

Double-Acting Telescopic Cylinders

A double-acting telescopic cylinder should be fully retracted when not in use.

A double-acting telescopic cylinder should not be extended until it has been fully retracted. A partially extended cylinder with pressure relieved may drift out of position. This can happen if a cylinder experiences vibration, such as an ejector or push out cylinder does in a refuse body. If this happens and the cylinder is then extended, the out of position plunger or sleeves will rapidly reposition themselves and possibly cause high pressure oil to be trapped on the retract side of the cylinder. This could cause a stage / sleeve to bulge and or the packing and bearings to be blown out from under a head nut.

Do not operate a packer / ejector cylinder with a misaligned blade. If the packer / ejector blade is bent, damaged, or if the blade slide shoes or guide track assembly are worn out, this can cause excessive side loading to the cylinder damaging it internally or bending a plunger or sleeve.

If the hydraulic system uses quick disconnects (such as on a transfer trailer) or holding / lock type valves, make sure they are properly connected. If not, oil may become trapped in the cylinder causing an excessive pressure build up and damage to the cylinder. This is particularly true if there is a blockage on the retract side of the cylinder and the cylinder is then extended. This could internally intensify the pressure 10 times or more inside the cylinder. (Example; The pump develops 2,000 P.S.I. trying to extend the cylinder, oil pressure trapped on the retract side of the cylinder could see 20,000 P.S.I.)

Do not operate a cylinder at pressures above factory recommended operating pressures (Normally 2,000 P.S.I. unless otherwise approved). Make sure hydraulic pump is developing required G.P.M., Double-acting telescopic cylinders normally require 15 G.P.M. to retract properly.

Most double-acting telescopic cylinders will self bleed themselves of air. Upon installation of a new cylinder this will require cycling the cylinder approximately 10 times to the complete extend and retract positions with no load against it. Check to make sure stages sequence properly. When extending, the largest stage should move first then the next largest, etc. and when retracting, the smallest should move first then the next smallest, etc.

On Roll Off units, if the Lift Cylinders are not completely extended when a container is being pulled onto the hoist, the lift cylinders may be pulled open by the weight of the load. Then as the container is pulled over center, the cylinders will be forced closed until they hit the column of oil inside the cylinders causing a sudden pressure surge. If the lift cylinders are pulled open by the load, they should be extended with the control valve to fill them with oil before pulling the container on the rest of the way. Care should be taken if moving Roll Off unit with tilt cylinders extended, avoiding sudden stops or jolts.

On Roll Off units dropping off a loaded container, feather control valve to avoid any pressure surges in the reeving / cable cylinders as gravity pulls the container to the ground.

On Roll Off units, if the container is not evenly loaded and is heavy on one side, the lift cylinders may mis-stage. When the plunger / sleeves attempt to correct themselves, there may be a sudden pressure surge, possibly damaging the cylinder.

Storage and Installation

STORAGE

It pays to keep spare hydraulic cylinders on hand for use when you need them. But, you must know and follow these recommended storage practices or the cylinders can be ruined. Hydraulic cylinders, though often large and unwieldy, are precision machines with finely finished parts and close tolerances. And they're expensive. So handle them with care.

For optimum storage life, hydraulic cylinders should be kept in an environment that is protected from excessive moisture and temperature extremes. A hot, dry desert climate with cold nights, for example, must be accommodated when choosing the storage area. Daytime heat quickly bakes oil out of sealing materials, which causes leaks and rapid wear when the cylinder is placed in service. Cooling at night causes water condensation and corrosion damage to wear surfaces. Storage areas that allow exposure to rain, snow and extreme cold must like wise be avoided.

It's best to store cylinders indoors if possible. But indoors or out, be sure that plugs or closures are properly installed in all ports to keep out moisture and dirt. However, overtightening of port plugs should be avoided. Widely varying temperatures and tightly closed ports may cause pressure inside the cylinder to build up to the point where the piston moves far enough to expose the rod to corrosion or contamination. Try to choose a storage location where the cylinders are protected from physical damage. Even a little ding from a falling bar or forklift tine can cause trouble later.

Cylinders, Particularly large ones, should be stored closed in a vertical position with the rod end down. Be sure they're blocked securely to keep them from toppling. Storing with the rod ends down keeps oil on the seals, which protects them from drying out. This is more critical with fabric and butyl seals than with urethane sealing materials. Storing single-acting cylinders with the rod end up can cause port closures to pop open and leak, exposing the sleeves to corrosion damage and contamination. Storing with the rod end down also discourages the temptation to lift a cylinder by the rod eye – a dangerous practice. If horizontal storage cannot be avoided, the rod or cylinder should be rolled into a new position every two months or so to prevent drying, distortion and deterioration of the seals. Don't forget that a cylinder can be a major source of contamination. A small scratch or nick on the sleeve will quickly shred packing and contaminate the system. Store cylinders carefully and keep them clean.

The following procedures should be followed in order to prevent oxidation and maintain the surfaces of a mounted hydraulic cylinder during idle periods. These idle periods may include; inventory units, demo units, out of service units, etc.

- All machined surfaces left expose should be coated with a light film of grease, if not oxidation will occur.
- If oxidation is present, apply a light coat of oil to the surfaces.
- Buff surfaces with 320 or 400 grit sandpaper. Do not buff surfaces up and down the length, buff only around the circumference.
- If after buffing, the surfaces show evidence of oxidation damage i.e., pitting, the cylinder should be inspected by an authorized service center for evaluation.
- Operation of a hydraulic cylinder with surface damage will shorten the longevity and preclude any warranty express or implied.

INSTALLATION

· Cleanliness is an important consideration, and Parker cylinders are shipped with the ports plugged to protect them from contaminants entering the ports. These plugs should not be removed until the piping is to be installed. Before making the connection to the cylinder ports, the piping should be thoroughly cleaned to remove all chips or burrs which might have resulted from threading or flaring operations. One small foreign particle can cause premature failure of the cylinder or other hydraulic system components. If oxidation is present, apply a light coat of oil to the surfaces.

· Proper alignment of the cylinder piston rod and its mating component on the machine should be checked in both the extended and retracted positions. Improper alignment will result in excessive rod gland and/or cylinder bore wear.

· Cylinders operating in an environment where air drying material are present such as fast- drying chemicals, paint, or welding splatter, or other hazardous conditions such as excessive heat, should have shields installed to prevent damage to the piston rod and piston rod seals.

Hydraulic Theory

The basis for all hydraulic systems is expressed by Pascal's law which states that the pressure exerted anywhere upon an enclosed liquid is transmitted undiminished, in all directions, to the interior of the container. This principle allows large forces to be generated with relatively little effort. As illustrated, a 5 pound force exerted against a 1 inch square area creates an internal pressure of 5 psi. This pressure, acting against the 10 square inch area develops 50 pounds of force.

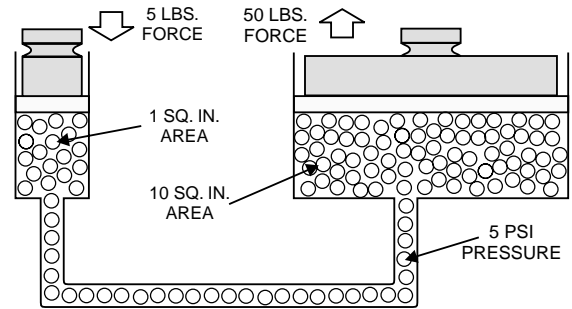

In a basic hydraulic circuit, the force exerted by a cylinder is dependent upon the cylinder bore size and the pump pressure. (There is no force generated unless there is resistance to the movement of the piston). With 1000 psi pump pressure exerted against a 12 square inch piston area (approximately 4" dia.), a force of 12,000 pounds is developed by the cylinder. The speed at which the piston will move is dependent upon the flow rate (gpm) from the pump and the cylinder area. Hence, if pump delivery is 1 gallon per minute (231 cu. in./min.) the cylinder piston will move at a rate of 19.25 in./min. (231 cu. in. ÷ 12 sq. in./min.).

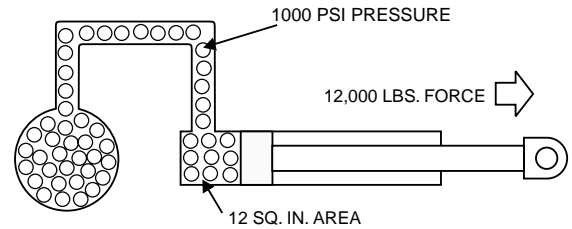

The simplest hydraulic circuit consists of a reservoir, pump, relief valve, 3-way directional control valve, single acting cylinder, connectors and lines. This system is used where the cylinder piston is returned by mechanical force. With the control valve in neutral, pump flow passes through the valve and back to the reservoir. With the valve shifted, oil is directed to the piston side of the cylinder, causing the piston to move, extending the rod. If the valve is returned to neutral, the oil is trapped in the cylinder, holding it in a fixed position, while pump flow is returned to the reservoir. Shifting the valve in the opposite direction permits the oil to pass through the valve back to the reservoir. The relief valve limits the system pressure to a pre-set amount. Relief valves are commonly incorporated into the directional control valve.

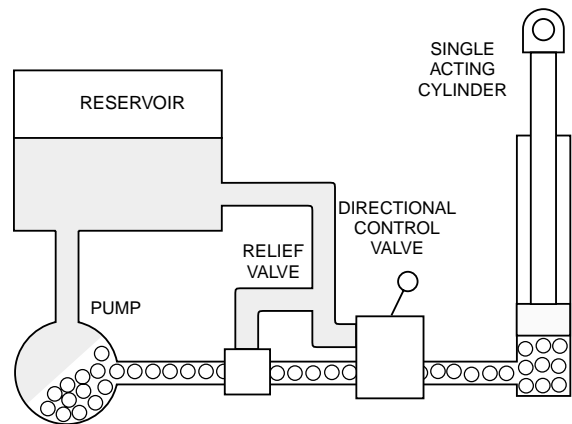

A hydraulic system using a double acting cylinder and a 4-way valve differs from a single acting cylinder system in that the cylinder can exert force in both directions. With the control valve in neutral, flow is returned to the reservoir. When shifted in one direction, oil is directed to the piston side of the cylinder, causing the cylinder to extend. Oil from the rod side passes through the valve back to the reservoir. If the valve is shifted to neutral, oil in the cylinder is trapped, holding it in a fixed position. When the valve is shifted in the opposite position, oil is directed to the rod side of the cylinder, causing the cylinder to retract. Oil from the piston side passes through the valve back to the reservoir. Cylinder extend force is the result of pressure (psi) times the piston area (minus any force resulting from the pressure acting against the rod side of the piston). Retract force is a result of the pressure (psi) times the area difference between the rod and the piston (minus any force resulting from pressure acting against the piston side of the cylinder).

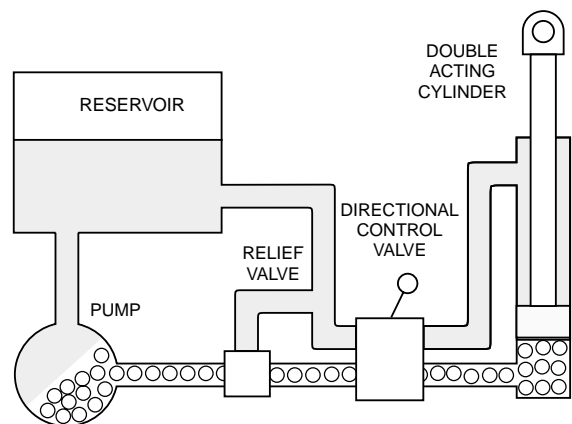

All of the systems described above are open center systems due to the oil flowing through the control valve back to the tank. Most systems are this type. Closed center systems use control valves with the inlet port blocked and variable displacement pumps. With the control valve in neutral, the pump is "de-stroked" to zero flow.

Designing With Cylinders

The function of a cylinder in a fluid power system is to convert energy in the fluid stream into an equivalent amount of mechanical energy. Its power is delivered in a straight-line, push-pull motion.

Graphic Symbols: Following diagram illustrates standard ANSI (American National Standards Institute) graphic symbols for use in circuit diagrams. Six of the more often used are shown:

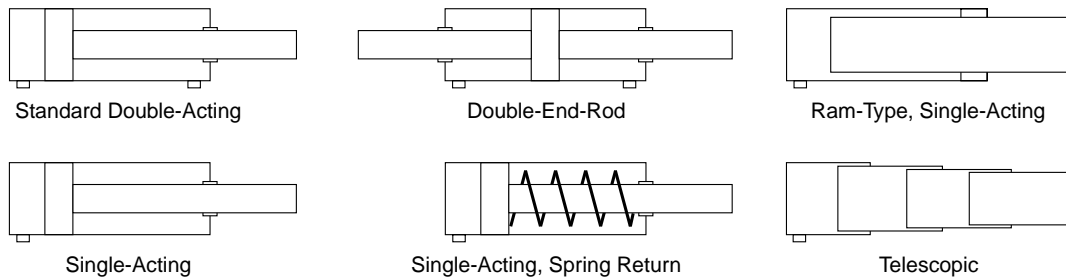

Standard ANSI (American National Standards Institute) Graphic Symbols for Use in Circuit Diagrams.

The standard double-acting cylinder with piston rod out one end, is used in the majority of applications. It develops force in both directions of piston travel. The double-end-rod type is a variation of the standard cylinder but having a piston rod extending out both end caps. It is occasionally used where it is necessary to have equal area on both sides of the piston, such as a steering application, or where one of rod extensions is to be used for mounting a cam for actuation of a limit switch, or for mounting a stroke limiting stop. The single-acting cylinder develops force in one direction, and is retracted by the reactive force from the load or an internal or external spring. The single-acting ram is a construction often used on fork lift mast raise, or a refuse body tailgate raise, or a high tonnage press cylinders. The telescoping cylinder is built in both single-acting and double-acting types. Its purpose is to provide a long stroke with a relatively short collapsed length. The single-acting telescopic is a construction often used to raise dump trucks and dump trailers. The double-acting telescopic is a construction often used in garbage bodies to pack and eject the load.

Force Produced by a Cylinder:

A standard double-acting cylinder has three significant internal areas. The full piston area when exposed to fluid pressure, produces force to extend the piston rod. The amount of this force, in pounds, is calculated by multiplying piston square inch area times gauge pressure, in PSI.

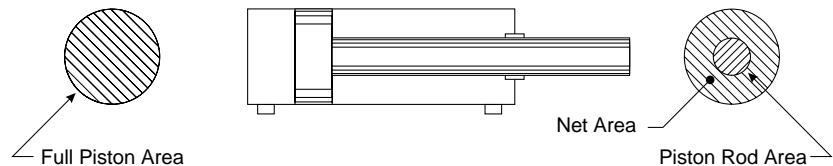

Significant Areas in a Double-Acting Cylinder, Single-End-Rod Type.

The "net" area on the front side of the piston is less than full piston area because part of the piston surface is covered by the rod. Net area is calculated by subtracting rod area from full piston area. Because net area is always less than piston area, cylinder force for rod retraction is always less than can be developed for extension when working at the same pressure.

Cylinder Force Against a Load: The force which a cylinder can exert against a load is determined by making two calculations. First, extension force is calculated according to piston area and PSI pressure against it. Then, the opposing force on the opposite side of the piston is calculated the same way. Net force against a load is the difference between the two.

Caution! It is incorrect, on a single-end-rod cylinder to calculate cylinder net force as piston area times ΔP (pressure drop, psid) across the piston. This is true only for double-end-rod cylinders which have equal areas on both sides of the piston.

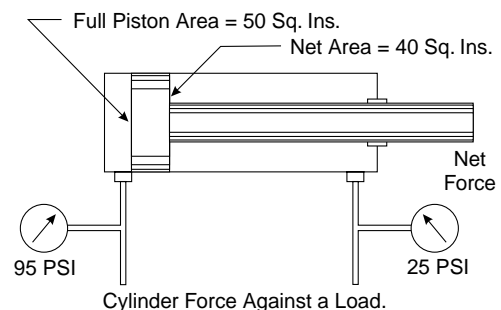

Example: The extension force is 95 PSI x 50 sq. in. = 4750 lbs. The opposing force on the rod side is 25 PSI x 40 sq. in. = 1000 lbs. Therefore, the net force which the cylinder can exert against a load in its extension direction is 4750 - 1000 = 3750 lbs. In making cylinder force calculation we sometimes assume that the opposite side of the piston is at atmospheric pressure, and that the counter-force is zero. On some kinds of loads this can lead to serious error.

Note: Most designers try to eliminate back pressure to get full extend force, but there will always be back pressure.

Designing With Cylinders

Standard catalog cylinder models are not designed to take any appreciable side load on the piston rod. They must be mounted so the rod is not placed in a bind at any part of the stroke. If the direction of the load changes during the stroke, hinge mounting must be used on both the rod end and rear end. Use guides on the mechanism, if necessary, to assure that no side load is transmitted to the cylinder rod or piston.

Rod Buckling

Column failure or buckling of the rod may occur if the cylinder stroke is too long relative to the rod diameter. The exact ratio of rod length to rod diameter at which column failure will occur cannot be accurately calculated, but the "Column Strength" table in this manual shows suggested safe ratios for normal applications.

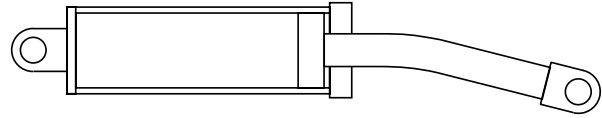

Tension and Compression Failures

All standard cylinders have been designed with sufficiently large piston rods so failure will never occur either in tension or compression, provided the cylinder is operated within the manufacturers pressure rating.

Rod Bearing Failure

Rod bearing failures usually occur when the cylinder is at maximum extension. Failures occur more often on hinge or trunnion mount cylinders, in which the rear support point is located considerably behind the rod bearing. If space permits, it is wise to order cylinders with longer stroke than actually required, and not permit the piston to approach to the front end while under full load.

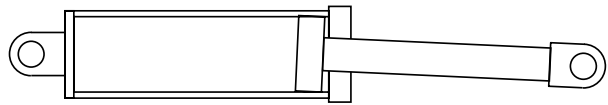

Stop Collar

On those application where it is necessary to let the piston "bottom out" on the front end, the cylinder may be ordered with a stop collar. The stop collar should be especially considered on long strokes if the distance between support exceeds 10 times the rod diameter, if the maximum thrust is required at full extension, and if the cylinder has a rear flange, clevis, tang, or trunnion mounting.

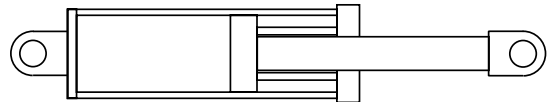

MINIMUM PISTON ROD DIAMETER

Figures in body of chart are suggested minimum rod diameters, in inches.

Load, Pounds	Exposed Length of Piston Rod, Inches / Rod Diameter, Inches							
	10"	20"	40"	60"	70"	80"	100"	120"
1,000			3/4	1				
1,500			13/16	1-1/16				
2,000		5/8	7/8	1-1/8	1-1/4	1-3/8		
3,000		11/16	15/16	1-3/16	1-3/8	1-1/2		
4,000		3/4	1	1-1/4	1-7/16	1-9/16	1-7/8	
6,000	13/16	7/8	1-1/8	1-3/8	1-9/16	1-5/8	1-7/8	
8,000	15/16	1	1-3/16	1-1/2	1-5/8	1-3/4	2	2-1/4
10,000	1	1-1/8	1-5/16	1-9/16	1-3/4	1-7/8	2-1/8	2-3/8
15,000	1-3/16	1-1/4	1-7/16	1-3/4	1-3/4	2	2-1/4	2-1/2
20,000	1-3/8	1-7/16	1-5/8	1-7/8	2	2-1/8	2-7/16	2-3/4
30,000	1-11/16	1-3/4	1-7/8	2-1/8	2-1/4	2-3/8	2-11/16	3
40,000	2	2	2-1/8	2-3/8	2-1/2	2-5/8	2-7/8	3-1/4
60,000	2-3/8	2-7/16	2-1/2	2-3/4	2-3/4	2-7/8	3-1/4	3-1/2
80,000	2-3/4	2-3/4	2-7/8	3	3	3-1/4	3-1/2	3-3/4
100,000	3-1/8	3-1/8	3-1/4	3-3/8	3-1/2	3-1/2	3-3/4	4
150,000	3-3/4	3-3/4	3-7/8	4	4	4-1/8	4-3/8	4-1/2
200,000	4-3/8	4-3/8	4-3/8	4-1/2	4-3/4	4-3/4	4-7/8	5
300,000	5-3/8	5-3/8	5-3/8	5-1/2	5-1/2	5-1/2	5-3/4	6

Cylinder Working a Rotating Lever:

A cylinder working a hinged lever can exert its maximum force on the lever only when the lever axis and cylinder axis are at right angles. When Angle "A" is greater or less than a right angle, only part of the cylinder force is effective on the lever. The cylinder force is found by multiplying the full cylinder force times the sine (sin) of the least angle between cylinder and lever axes. Cylinder Force, FF, is horizontal in this figure. Only that portion, EF, which is at right angles to the lever axis is effective for turning the lever. The value of EF varies with the acute angle "A" between the cylinder and lever axis.

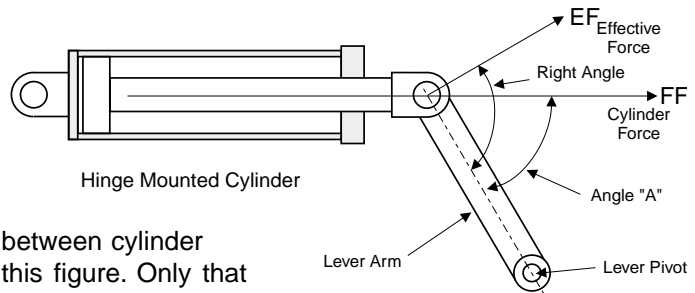

Example: Find the effective force exerted by a 3-inch bore cylinder against a lever when the cylinder is operating at 3000 PSI and when its axis is at an angle of 55 degrees with the lever axis.

First, find the full force developed by the cylinder: FF (full force) = 7.07 (piston area) x 3000 PSI = 21,210 lbs.

Next, find the effective force at 55°: EF (effective force) = 21,210 x 819 (sin 55°) = 17,371 lbs.

Since maximum cylinder force is delivered in the right angle position, the hinge points for the cylinder and lever should be located, if possible, so the right angle falls close to the lever position which requires the greatest torque (force).

Note: The working angles on a hinged units, such as a dump truck, refuse body packer blade, or a crane, are constantly changing, it may be necessary to construct a rough model on a sheet of paper, to exact scale, with cardboard arms and thumbtack hinge pins. This will show the point at which the greatest cylinder thrust is needed. An exact calculation can then be made for this condition.

POWER FACTOR TABLE
Trigonometric Sines and Cosines

Angle, Degrees	Sine (sin)	Cosine (cos)	Angle, Degrees	Sine (sin)	Cosine (cos)	Angle, Degrees	Sine (sin)	Cosine (cos)
1	0.0175	0.9998	31	0.5150	0.8572	61	0.8746	0.4848
2	0.0349	0.9994	32	0.5299	0.8480	62	0.8829	0.4695
3	0.0523	0.9986	33	0.5446	0.8387	63	0.8910	0.4540
4	0.0698	0.9976	34	0.5592	0.8290	64	0.8988	0.4384
5	0.0872	0.9962	35	0.5736	0.8192	65	0.9063	0.4226
6	0.1045	0.9945	36	0.5878	0.8090	66	0.9135	0.4067
7	0.1219	0.9925	37	0.6018	0.7986	67	0.9205	0.3907
8	0.1392	0.9903	38	0.6157	0.7880	68	0.9272	0.3746
9	0.1564	0.9877	39	0.6293	0.7771	69	0.9336	0.3584
10	0.1736	0.9848	40	0.6428	0.7660	70	0.9397	0.3420
11	0.1908	0.9816	41	0.6561	0.7547	71	0.9455	0.3256
12	0.2079	0.9781	42	0.6691	0.7431	72	0.9511	0.3090
13	0.2250	0.9744	43	0.6820	0.7314	73	0.9563	0.2924
14	0.2419	0.9703	44	0.6947	0.7193	74	0.9613	0.2756
15	0.2588	0.9659	45	0.7071	0.7071	75	0.9659	0.2588
16	0.2756	0.9613	46	0.7193	0.6947	76	0.9703	0.2419
17	0.2924	0.9563	47	0.7314	0.6820	77	0.9744	0.2250
18	0.3090	0.9511	48	0.7431	0.6691	78	0.9781	0.2079
19	0.3256	0.9455	49	0.7547	0.6561	79	0.9816	0.1908
20	0.3420	0.9397	50	0.7660	0.6428	80	0.9848	0.1736
21	0.3584	0.9336	51	0.7771	0.6293	81	0.9877	0.1564
22	0.3746	0.9272	52	0.7880	0.6157	82	0.9903	0.1392
23	0.3907	0.9205	53	0.7986	0.6018	83	0.9925	0.1219
24	0.4067	0.9135	54	0.8090	0.5878	84	0.9945	0.1045
25	0.4226	0.9063	55	0.8192	0.5736	85	0.9962	0.0872
26	0.4384	0.8988	56	0.8290	0.5592	86	0.9976	0.0698
27	0.4540	0.8910	57	0.8387	0.5446	87	0.9986	0.0523
28	0.4695	0.8829	58	0.8480	0.5299	88	0.9994	0.0349
29	0.4848	0.8746	59	0.8572	0.5150	89	0.9998	0.0175
30	0.5000	0.8660	60	0.8660	0.5000	90	1	0

Cylinders on Cranes and Beams:

Example 1: Calculation to find cylinder force required to handle 15,000 lbs. when the beam is in the position shown.

First find the force F2 at right angles to the beam which must be present to support the 15,000 lb. load.

$$F2 = W \times \cos 50^\circ = 15,000 \times .643 = 9,645 \text{ lbs.}$$

Next, find the force F1, also at right angles to the beam, which must be produced by the cylinder to support the 15,000 lb. load. This is calculated by proportion. F1 will be greater than F2 in the same ratio that arm length 17 feet is greater than arm length 5 feet.

$$\text{Arm length ratio of } 17 \div 5 = 3.4.$$

Therefore, $F1 = 9,645 \times 3.4 = 32,793 \text{ lbs.}$

Finally, calculate the cylinder force, at an angle of 30° to the beam, which will produce a force of 32,793 lbs. at its rod hinge point at right angles to the beam.

$$F (\text{cylinder force}) = F1 \div \sin 30^\circ = 32,793 \div .500 = 65,586 \text{ lbs.}$$

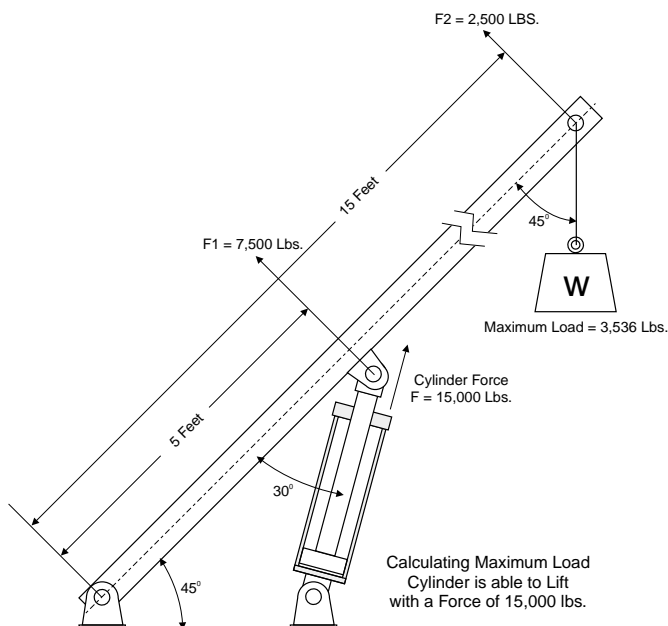
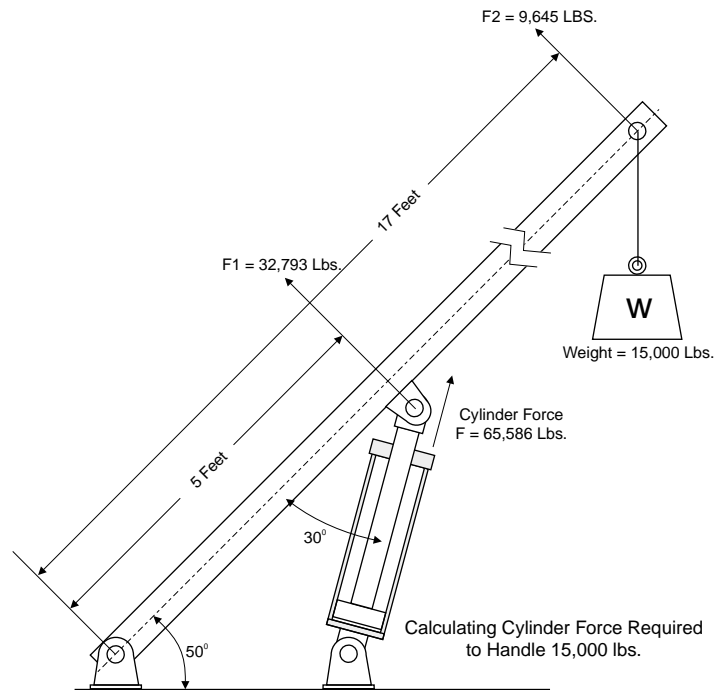

Example 2: Calculation to find maximum load that can be lifted with a cylinder force of 15,000 lbs. when the beam is in the position shown.

First, translate the cylinder thrust, F, of 15,000 lbs. into 7,500 lbs. at right angles to the beam using power factor of 0.500 (sin) from the power factor table, for a 30° angle.

Next, translate this to F2, 2,500 lbs. at the end of beam where the weight is suspended. This is done with simple proportion by the length of each arm from the base pivot point. F2 is 1/3rd F1 since the lever arm is 3 times as long.

Finally, find the maximum hanging load that can be lifted, at a 45° angle between beam and load weight, using sin (power factor) for 45° :

$$W = F2 \div \sin 45^\circ = 2500 \div 0.707 = 3535 \text{ lbs.}$$

Calculations for a Heavy Beam:

On a heavy beam it is necessary to calculate not only for concentrated loads such as the suspended weights and cylinder thrust, but to figure in the weight of the beam itself. If the beam is uniform, so many pounds per foot of length, the calculation is relatively easy. In the example shown in figure "B", the beam has a uniform weight of 150 lbs.

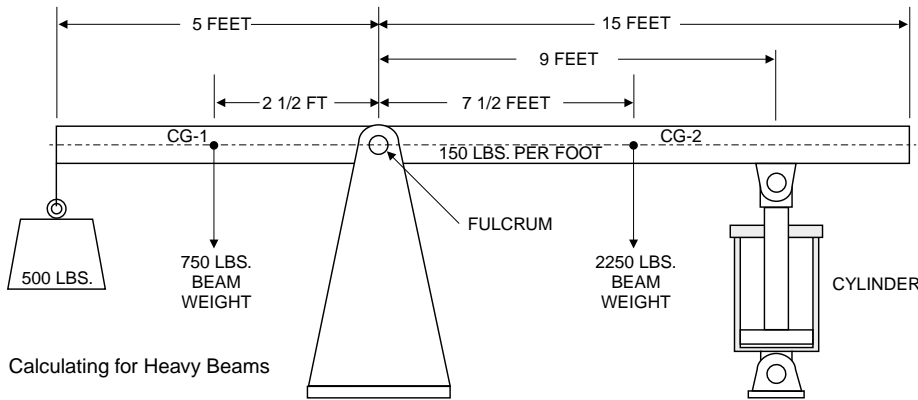

per foot, is partially counterbalanced by a weight of 500 lbs. on the left side of the fulcrum, and must be raised by the force of a cylinder applied at a point 9 feet from the right side of the fulcrum.

The best method of solution is to use the principle of moments. A moment is a torque force consisting of (so many) pounds applied at a lever distance of (so many) feet or inches. The solution here is to find how much cylinder thrust is needed to just balance the beam. Then, by increasing the hydraulic cylinder

thrust 5 to 10% to take care of friction losses, the cylinder would be able to raise the beam.

Using the principle of moments, it is necessary to calculate all of the moment forces which are trying to turn the beam clockwise, then calculate all the moment forces trying to turn the beam counter-clockwise, then subtract the two. In this case they must be equal to balance the beam.

Clockwise moment due to the 15 feet of beam on the right side of the fulcrum: This can be considered as a concentrated weight acting at its center of gravity 7 1/2 feet from the fulcrum. $\text{Moment} = 150 \text{ (lbs. per foot)} \times 15 \text{ feet} \times 7 \frac{1}{2} \text{ feet} = 16,875 \text{ foot pounds.}$

Counter-clockwise moment due to the 5 feet of beam on the left side of the fulcrum: $150 \text{ (lbs. per foot)} \times 5 \text{ feet} \times 2 \frac{1}{2} \text{ feet (CG distance)} = 1875 \text{ foot pounds.}$

Counter-clockwise moment due to hanging weight of 500 pounds: $500 \times 5 \text{ feet} = 2500 \text{ foot lbs.}$

Subtracting counter-clockwise from clockwise moments: $16,875 - 1875 - 2500 = 12,500 \text{ foot pounds}$ that must be supplied by the cylinder for balance condition. To find cylinder thrust: $12,500 \text{ foot pounds} \div 9 \text{ feet (distance from fulcrum)} = 1388.8 \text{ pounds.}$

Remember when working with moments, that only the portion of the total force which is at right angles to the beam is effective as a moment force. If the beam is at an angle to the cylinder or to the horizontal, then the effective portion of the concentrated or distributed weight, and the cylinder thrust, can be calculated with the power factors (refer to chart).

Designing With Cylinders Telescopic Cylinders

The great advantage telescopic cylinders have over conventional rod-type cylinders is their ability to provide an exceptionally long stroke from a compact initial package. The collapsed length of typical telescopic cylinders varies between 20% to 40% of their extended length. Thus, when mounting space is limited and the application needs a long stroke, a telescopic cylinder is a natural solution.

For example, a dump body needs to be tilted 60 degrees in order to empty completely. If the body or trailer is fitted with a conventional rod-type cylinder - with a one-piece barrel and stroke long enough to attain that angle - the dump body could not return to a horizontal orientation for highway travel because of the cylinder's length, even when fully retracted. A telescopic cylinder easily solves this problem.

Telescopic hydraulic cylinders are relatively simple devices, but their successful application requires an understanding of this component's idiosyncrasies. Knowledge of how telescopic cylinders work and which special application criteria to consider will enable you to design them safely and economically into equipment.

Main and Stages

As the name infers, Telescopic cylinders are constructed like a telescope. Sections of DOM (drawn over mandrel) steel tubing with successively smaller diameters nest inside each other. The largest diameter section is called the *main* or *barrel*; the smaller-diameter sections that move are called *stages*; The smallest stage is also called the *plunger*. The maximum practical number of moving stages seems to be six. Theoretically, cylinders with more stages could be designed but their stability problem would be daunting.

Telescopic cylinders normally extend from the largest stage to the smallest. This means the largest stage - with all the smaller stages nested inside it - will move first and complete its stroke before the next stage begins to move. This procedure will continue for each stage until the smallest-diameter stage is fully extended. Conversely, when retracting, the smallest-diameter stage will retract fully before the next stage starts to move. This continues until all stages are nested back in the main.

Basic Cylinder Types

As with conventional cylinders, the two basic types of telescopic hydraulic cylinders are *single-* and *double-acting*.

Single-acting telescoping cylinders extend under hydraulic pressure and rely on gravity or some external mechanical force for retraction. Single-acting cylinders are used in applications where some form of load is always on the cylinders. The classic single-acting telescopic applications are dump trucks and dump trailers. Pressurized oil extends the telescopic cylinder to raise one end of the dump body and expel its load. When pressure is released, the weight of the dump body forces oil out of the cylinder and it retracts.

Double-acting telescopic cylinders are powered hydraulically in both directions. They can be used in applications where neither gravity nor external force is available. They are well suited to noncritical positioning applications requiring out-and-back movement of a substantial load. A classic application is the packer-ejector cylinder in refuse vehicles and transfer trailers. The horizontally mounted cylinder pushes a platen to compress the load, then must retract with the platen so more material can be added. Gravity cannot help, so a double-acting cylinder is used.

Bearings and Seals

Each stage is supported within each successively larger stage by at least two bearings. One is at the bottom outside diameter or *piston end* of the stage, and the other is at the top internal diameter or *packing section* of the next larger stage. The distance between these two bearings determines the degree by which one stage overlaps the next. Generally, this distance or overlap must increase as overall stroke increases in order to resist deflection caused by the weight of extended stages and the load.

There are several designs for sealing telescopic cylinders. One of the most common designs for sealing telescopic cylinders is the use of several hinged chevron vee seals and / or one-piece, multi-lip seals with hinged lips molded in place. These seals are held in place by a stop ring or snap ring and packing nut and they use guide bearings on the sleeve piston. The internal diameter "ID" of each stage is sealed against the outer diameter "OD" of the next smaller stage nested inside it. The style and placement of these seals varies among cylinder manufactures. The style of seal also depends on its particular function. Zero-leakage, multiple-lip soft seals are usually found in the internal diameter at the packing section of the main and moving stages. Low-leakage hard seals are found on the piston end of double-acting telescopic cylinders. These piston seals allow the cylinder to retract under pressure.

Another design used on some single-acting telescopic cylinders, is the use of soft, zero leakage seals on the piston, which in turn use the full bore of the next larger stage as the effective area for extend force. These same seals contain the oil in the cylinder. The upper end of the cylinder, where the soft seals normally would be found, now contains a bearing for guidance. If any type of seal is used in the upper end of this telescopic cylinder design, it is usually a wiper/seal combination to exclude contaminants from entering the cylinders. With either type, the many sealing surfaces must compensate for normal deflection of stages as the cylinder extends.

Designing With Cylinders Telescopic Cylinders

The cylinder design with the bearing on the piston and the seal on the other end is called a *displacement-type cylinder*. The single-acting design with a seal on the piston and a bearing at what normally would be the packing end approaches the classification of ram-type cylinder. Performance is similar to a double-acting rod-type cylinder with pressurized oil being supplied only to the piston side. All the telescopic stages would stroke in this way.

Double-Acting Telescopic Cylinders

Normally extension of a double-acting telescopic cylinder occurs in the same manner as with the single-acting type.

Retraction of double-acting telescopic cylinders is made possible by sealing each moving stage's piston area outside diameter with the next larger stage's inside diameter and building internal oil-transfer holes into each moving stage. The oil-transfer holes are located just above the pistons in the body of the stage. The retraction port normally is located in the top of the smallest stage. Oil flows through this port and into the smallest stage. The oil-transfer hole allows oil to enter and pressurize the volume between the next stage's internal diameter and the smaller stage's outer diameter. Pressure in this volume generates the force to move or retract the smaller stage into the larger stage.

Once this stage is fully retracted, the oil-transfer hole in the next larger stage is exposed to allow oil flow for it to retract. This retraction process continues automatically until all stages have retracted into the main. The seal on each stage selects the areas against which pressure will work.

Locating the retract port on the top of the smallest stage is the simplest way to design a double-acting telescopic cylinder, but this port location typically requires an arrangement of hoses, hose protection, and hose reels to deliver oil to the moving stage. To avoid having fluid power ports spaced far apart when the cylinder is fully extended, most double-acting telescopic cylinder designs locate both fluid ports in the smallest stage or plunger. The cylinder is then mounted so that the smallest stage or plunger is stationary and the larger and heavier stages would be the ones that move as the cylinder extends.

In some instances a double-acting telescoping cylinder can be designed where both ports are located in the stationary main barrel. Cylinder size (diameter and stroke) and the number of moving stages determine whether this is possible. If it is, the more-complicated internal passages for oil flow require a double wall and or a special trombone type telescopic design.

Piston seals on double-acting telescoping cylinders are normally manufactured from a hard substance such as cast iron, ductile iron or glass-reinforced nylon. The hard seals are needed to limit abrasion between the oil transfer holes and ports over which they must pass.

Single- and Double-Acting Combinations

There are a few unusual types of telescoping cylinders designed for specific applications. For example, a manufacturer of oil well equipment uses a type composed of both single- and double-acting stages to position a work-over rig. The work-over rig is a derrick or tower that is transported horizontally to the well site on a trailer. There, telescopic cylinders extend to swing the rig into a vertical position. When the rig's work is done, the telescopic cylinder pulls the rig to begin the transition from vertical back to horizontal. However, once the rig has started to tilt, no more pull force is needed because of the rig's weight and gravity will continue to retract the cylinder. In other words, the cylinder needs hydraulic power for the first part of its retraction stroke, but then operates as a single-acting unit.

In this type of design, the smallest moving stage is designed to be double-acting; the others are single-acting. The small stage can then provide push force to raise the rig, and pull force to start it back down. It is not unusual to design this type cylinder as a *skip-a-sleeve design*. Skip-a-sleeve design is as its name implies, a sleeve or stage is skipped during design. Normally a telescopic stage diameter increases approximately every inch, example; sleeve diameter may be 3.75" fits into a 4.25" bore, 4.75" fitting into 5.25" bore, etc. In a skip-a-sleeve design, a sleeve is removed to increase the effective area and the retract force of the smallest sleeve or plunger, example; plunger diameter is 2.75" and fits into the 4.25" bore of the 4.75" sleeve, thus increasing effective area and retract force.

Constant-Thrust / Constant-Speed

A special telescopic cylinder - known as a *constant-thrust/constant-speed cylinder* - is configured so that all moving stages will extend at the same time, providing an overall constant speed as well as a constant push force throughout its stroke when extending or retracting. This type of cylinder has been used to drive a drill head in underground mining, where such performance parameters are necessary and space is at a premium. The more-complicated design accomplishes the required action by trapping oil internally, matching extend and retract areas, and limiting the number of moving stages.

Designing With Cylinders Telescopic Cylinders

Design Considerations

Three familiar formulas determine the general operating characteristics of telescoping cylinders and can be manipulated to calculate the cylinder size required for a given cycle time or load. These formulas are:

$$F = A \times P$$

where:

F - force, lb

A - area, in²

P - operating pressure, psi

$$S = 19.2 \text{ Q/A}$$

where:

S - speed, fpm

Q - flow rate, gpm

$$T = V/231Q$$

where:

T - cycle time, min

V - cylinder volume (area X stroke), in³

The basic formulas for force, speed, and cycle time that apply to conventional rod-type cylinders also can be used with telescopic cylinders. To successfully apply these formulas, the designer must know which of the multiple areas and diameters to use. To calculate the force of any stage, you must decide which area will be substituted into the formulas. This area is determined by the placement of the seals that describe the boundaries of the area.

For example: the extend area of a double-acting stage is determined by the seals on the pistons. Thus, the appropriate area would be calculated from the internal diameter of the next larger stage. On retraction, the area of any double-acting stage is the difference between that stage's outside diameter and the inside diameter of the next larger stage.

Designers must remember that the extend area for each stage is different, so the extend force for each stage also is different. The differences in areas mean that in an application with a constant-displacement pump supplying the hydraulic system, each stage will move at a different speed. This speed difference for each stage also holds true during retraction of double-acting telescopic cylinders because each stage's retract area is different.

In both types of telescopic cylinders, the smallest stage determines the force capacity of the cylinder. This stage will usually have the smallest extend and retract area. During extension, this stage will generate the cylinder's minimum force; during retraction, this stage normally generates the maximum force. A double-acting telescopic cylinder can exert no more retraction force than the smallest retract area provides.

After determining the effective diameter of each stage, volume can be approximated by dividing stroke by the number of stages and multiplying the quotient by each effective area. The sum of these volumes equals the approximate volume of oil to extend the cylinder. Reservoir volume should equal the cylinder's extended volume plus an initial volume of oil to fill the fully retracted cylinder and an adequate reserve for make-up oil.

Pump capacity is determined by applying the formula for speed to solve for Q (flow rate, gpm) in each stage. Inlet porting at the cylinder must be sized to accommodate the required flow for a given extension speed, of course.

Special Design Considerations

Designers should *never* treat the telescopic cylinders as structural members. These cylinders should be used to generate work forces - not to stabilize the structure. They should be considered no more rigid than the columns of oil they contain. Telescopic cylinders always should be provided with mechanical support members.

Fully extended, long stroke telescopic cylinders can become very long, slender columns, making them susceptible to buckling. The structure of a telescopic cylinder can be considered as special as a stepped column with different diameter elements, each having a different moment of inertia. Additional overlap can help stabilize such a cylinder, but more overlap increases collapsed length as well as overall column length. Sometimes a cylinder diameter larger than required for the load may be needed to keep the cylinder safe under column loading.

As stated earlier, single-acting telescopic cylinders are extended by pressure and retracted by gravity or an external force. The extend speed is determined by the pump flow and flow capacity of the control valve. The retract speed is a function of the load on the cylinder and the ability of the hydraulic fluid to return to tank. Retraction speed can be controlled by metering return-oil flow through the control valve. Light loads and restricted flow slow down the retraction stroke. Most single-acting telescopic cylinders will not retract under their own weight. This is a result of several variables, including friction of the internal seals, attitude of the cylinder, and the type of mounting. A rigid mount with a low attitude may cause enough binding so that light loads cannot force the cylinder to retract.

As with any type of cylinder, heavy side loads should be avoided. Because of telescopic cylinder's multiple moving stages, side loading can cause internal binding that could result in mis-staging and possible stalling of the cylinder's movement. Because the overlap of each successive stage must be designed and manufactured with running and machining tolerances, these areas can act like hinges, allowing some movement. Longer overlap helps limit this movement, but cannot eliminate it. This is a Catch 22 design situation: the longer the overlap, the longer the cylinder's collapsed length.

Designing With Cylinders Telescopic Cylinders

Flow, Pressure Control

A three-way, three-position valve can provide raise, lower and hold control for a single-acting cylinder. Retraction speed of single-acting cylinders may be controlled by manually metering flow through the valve's return port. As an alternative, some systems use an orifice in the return line, valve, or cylinder port that is sized to limit flow and, thus, limit retraction speed.

Four-way, three-position valving is needed to perform the same control functions on double-acting types. The additional pathway provides a route to tank for oil displaced from the plunger end.

Dealing with Intensification

Due to its construction, double-acting telescopic cylinders will act as pressure intensifiers during extension and flow multipliers during retraction. These two phenomenon are directly related to the large difference in effective area between the extend and retract side of each stage piston. This ratio can be as high as 10:1, or even greater. During extension of a double-acting telescopic cylinder, hydraulic oil is pumped into the extend port and exhausted out the retract port. If exhaust flow is impeded or restricted, the retract side of the cylinder can be pressurized to a level equal to the extend pressure multiplied by the differential area ratio. A dead block of exhaust flow can produce pressures high enough to destroy the cylinder. If any type of holding or check valve is installed in the retract line or on the retract port, the pressure intensification phenomenon can become dangerous. In the case of a 10:1 stage, a 2000 psi main pressure would result in an intermediate plunger pressure of 20,000 psi if flow from plunger is dead blocked. A similar, though less hazardous condition often results when the plunger side outlet line is reduced for design reasons or as the result of clogging or misconnection. The circuit must be designed so that these valves open before (or simultaneously with) the application of extend pressure to the cylinder.

When a double-acting cylinder retracts, the opposite occurs. Oil is pumped into the retract port and exhausted through the extend port. The exhaust flow will be equal to the retract flow multiplied by the differential area ratio. With a 10:1 ratio, a 20-gpm retract flow becomes a 200-gpm exhaust flow. If the extend lines or valves are too small and flow is restricted, backpressure can occur in the cylinder to slow the retract speed. If the backpressure equals the pump's retract pressure, the cylinder will stall and not retract.

Telescopic cylinder manufacturers attempt to size the ports to eliminate or reduce the potential for this phenomenon, but designers should size other components in the hydraulic circuit with this in mind. Most problems relating to these phenomenon result from increasing pump flow or downsizing lines, connectors, or control valves after the cylinder has been specified for operation with larger components.

Seal Bypass

Piston seals in double-acting telescopic cylinders normally are manufactured from a hard substance, such as cast iron, ductile iron, or glass reinforced nylon. Hard seals are needed to resist abrasion when the seals slide across the transfer holes. However, these seals are not as efficient as soft urethane or rubber seals, so small amounts of oil can bypass them. This bypass flow actually can cause a cylinder to stall if pump flow is less than the seal's allowable leakage rate. This may become a problem if the cylinder is required to stroke at low speeds. Consequently, loading should be limited to a level slightly below the cylinder's rated force at a given pressure.

Bypass leakage also can allow a cylinder to drift in either direction while holding a load. Drift is extremely hazardous if the cylinder is holding a load on the retract area. If a piston drifts past the internal transfer holes in a stage, the retract oil will rapidly transfer to the extend area - causing the cylinder to extend abruptly. This is possible because the retract oil volume is less than the extend volume, due to the large differential area ratio. Therefore, a double-acting telescoping cylinder should not be expected to hold a load on retraction.

Summary

It should now be evident that specifying telescoping cylinders requires knowledge beyond that of conventional cylinders. The best insurance to guard against unforeseen problems — especially for those lacking familiarity with telescoping cylinders — is to draw from the experience of manufacturer's application engineers.

Manufacturer's of telescopic cylinders can (and have) altered their designs to suit a variety of special application considerations. Their application engineers should be eager to provide assistance in selecting or designing the right cylinder for your specific application, and advising about circuitry to operate it safely and efficiently.

Formulas

CYLINDER FORMULAS

Thrust or force of any cylinder:

$$F = A \times P$$

$$P = F \div A$$

$$A = F \div P$$

F = Force or thrust, in pounds

A = Piston area in square inches ($.7854 \times D^2$)

P = PSI (Gauge pressure in pounds per square inch)

$$\text{HP} = \frac{\text{Pounds of push (or pull)} \times \text{Distance (in feet)}}{550 \times \text{Time (in seconds)}}$$

HP = Horsepower

Circle Formula:

$$A = D \times D \times .7854$$

$$A = D^2 \times 0.7854$$

$$A = \pi \times R^2$$

$$A = \pi \times D^2 \div 4$$

$$\text{Circumference} = 2 \times R \times \pi$$

$$\text{Circumference} = \pi \times D$$

$$D = \sqrt{A/.7854}$$

A = Area in² (Area sq. in.)

R = Radius (1/2 of Diameter)

D = Diameter, inches

$\pi = 3.14$

Hydraulic Cylinder Piston travel speed:

$$V1 \text{ (in/min)} = \text{CIM} \div A$$

$$V2 \text{ (ft/min)} = Q \times 19.25 \div A$$

$$V3 \text{ (ft/sec)} = Q \times 0.3208 \div A$$

$$Q \text{ (GPM)} = 3.117 \times V3 \text{ (ft/sec)} \times A$$

$$Q \text{ (GPM)} = \text{CIM} \div 231$$

V1 = Velocity or piston travel speed, inches per minute

V2 = Velocity or piston travel speed, feet per minute

V3 = Velocity or piston travel speed, feet per second

CIM = Flow rate in cubic inches per minute (in³)

A = Effective area in square inches (in²)

Q = GPM Gallons per minute

1 Gallon = 231 in³ (cubic inch)

Volume required to move a piston a given distance:

$$V = A \times L$$

V = Volume in cubic inches (in³)

A = Area in square inches (in²)

L = Length or stroke in inches

Regenerative Cylinder

$$\text{Extend Speed} = \text{Rod Volume} \div \text{Flow Rate in}^3$$

$$\text{Area to Retract} = \text{Area to extend} - \text{Rod Area}$$

$$\text{Cylinder Ratio} = \text{Area to extend} \div \text{Area to retract}$$

Note:

Ratio can be used to calculate pressure intensification and flow intensification.

Effective force of a cylinder working at an angle to direction of the load travel:

$$F = T \times \sin A$$

T = Total cylinder force, in pounds

F = Part of the force which is effective, in pounds

A = Least angle, in degrees, between cylinder axis and load direction.

Moment Arm Equations / Levers:

$$F \times Df = W \times Dw$$

$$F = W \times Dw \div Df$$

$$W = F \times Df \div Dw$$

$$Df = W \div F \times Dw$$

$$Dw = F \div W \times Df$$

F = Cylinder force

Df = Cylinder force distance to pivot

W = Weight or Load Force

Dw = Weight or Load Force distance to pivot

Toggle Force:

$$T = F \times A \div 2 \times B$$

T = Toggle Force

F = Cylinder Force

A = Distance cylinder centerline to toggle

B = Remaining stroke

Force for piercing or shearing sheet metal:

$$F = P \times T \times \text{PSI}$$

F = Force required, in pounds

P = Perimeter around area to be sheared, in inches

T = Sheet thickness in inches

PSI = Shear strength rating of the material in pounds per square inch.

P.O. Check Application:

$$\text{Release PSI} = \frac{\text{Cap End Area} \times \text{Max. W.P.} - \text{Load}}{\text{Rod End Area}}$$

Max. W.P. = Pressure Rating of Components

$$\text{Ratio} = \frac{\text{Max Working PSI}}{\text{Release PSI}}$$

Example;

2 to 1 Ratio = 1 square inch (in²) at 1000 psi working pressure will open when a Release pressure of 500 psi is applied to a 2 square inches (in²) area.

Formulas

HYDRAULIC PUMP EQUATIONS

Horsepower Required to Drive Hydraulic Pump:

$$\text{HP} = \text{PSI} \times \text{GPM} \div 1714$$

$$\text{HP} = (\text{PSI} \times \text{GPM}) \div (1714 \times \text{EFFICIENCY})$$

HP = Horsepower
PSI = Gauge pressure in pounds per square inch
GPM = Oil flow in gallons per minute
EFFICIENCY = Efficiency of hydraulic pump

Important:

As all systems are less than 10% efficient and efficiency factor must be added to the calculated input horsepower.

Example:

Input hp = 10 gpm x 1500 psi ÷ 1714 (constant) = 8.75
hp x 0.85 (efficiency) = required input 10 hp

Rule of thumb:

For every 1 HP of drive, the equivalent of 1 GPM @ 1500 PSI can be produced.

Rule of thumb:

To idle a pump when it is unloaded will require about 5% of its full rated horsepower.

Note:

1 hp = 33,000 ft lbs per min or 33,000 lbs raised 1 ft in 1 min

1 hp = 550 ft. lbs. per second

1 hp = 746 Watts or 0.746 kw

1 hp = 42.4 Btu per min

1 hp = 2545 Btu per hour

BTU = The energy to raise one pound of water one degree Fahrenheit.

Flow Formulas:

$$\text{GPM (theoretical)} = \text{RPM} \times \text{CIR} \div 231$$

GPM = Oil flow in gallons per minute
CIR = Cubic Inch (in³) per Revolution
RPM = Pump revolutions per minute

$$\text{Volume required (gpm)} = \frac{\text{Volume Displaced} \times 60}{\text{Time (s)} \times 231}$$

$$\text{Flow rate (gpm)} = \frac{\text{Velocity (ft/s)} \times \text{Area (in}^2\text{)}}{0.3208}$$

Note:

Fluid is pushed or drawn into a pump
Pumps do not pump pressure, their purpose is to create flow. (Pressure is a result of resistance to flow).

Torque and horsepower relations:

$$\text{T} = \text{HP} \times 63025 \div \text{RPM}$$

$$\text{HP} = \text{T} \times \text{RPM} \div 63025$$

$$\text{RPM} = \text{HP} \times 63025 \div \text{T}$$

T = Torque, inch-lbs
RPM = Speed, revs / minute
HP = Horsepower

Note:

For Torque in foot-lbs use 5252 in place of 63025

Note:

Work (in lbs) = force (lbs) x distance (in)

Power = Force x Distance ÷ Time

$$\text{Theoretical Pressure} = \text{T} \times 6.28 \div \text{CIR}$$

T = Torque, inch-lbs
CIR = Cubic Inch (in³) per Revolution

Pump Efficiencies:

$$\text{Volumetric Efficiency} = \frac{\text{Actual GPM} \times 100}{\text{Theoretical Flow}}$$

$$\text{Mechanical Efficiency} = \frac{\text{Actual PSI} \times 100}{\text{Theoretical Pressure}}$$

$$\text{Overall Efficiency} = \frac{\text{Output HP} \times 100}{\text{Input HP}}$$

$$\text{Overall Efficiency} = \text{Mech. Eff.} \times \text{Volumetric Eff.}$$

Theoretical Flow = RPM x CIR ÷ 231

Theoretical Pressure = T x 6.28 ÷ CIR

Input HP = PSI x GPM ÷ 1714

Output HP = T x RPM ÷ 63025

T = Torque, inch-lbs
CIR = Cubic Inch (in³) per Revolution
GPM = Flow in gallons per minute
PSI = Gauge pressure in pounds per square inch
RPM = Pump revolutions per minute

Gear Displacement Calculation:

The volumetric displacement of a gear pump or motor can be approximated by measurement of the internal parts and substituting the values in the following formula:

$$\text{V} = 6.03 \times \text{W} \times (2 \times \text{D} - \text{L}) \times (\text{L} - \text{D} \div 2)$$

Where

V = displacement in in³/rev

W = gear width in inches

D = gear tip diameter in inches

L = dimension across both gears when meshed in inches

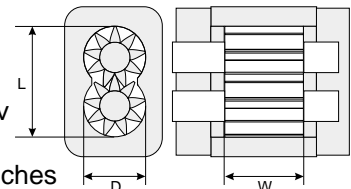

Formulas

HYDRAULIC MOTOR EQUATIONS

Note: Hydraulic motors are typically classified as high speed motors (500 - 10,000 rpm) or low speed motors (0 - 1,000) rpm.

Relationship between displacement and torque of a hydraulic motor:

$$\begin{aligned}T &= \text{HP} \times 63025 \div \text{RPM} \\ \text{HP} &= T \times \text{RPM} \div 63025 \\ \text{RPM} &= \text{HP} \times 63025 \div T\end{aligned}$$

Note:

For Torque in foot-lbs use 5252 in place of 63025

$$\begin{aligned}T &= \text{CIR} \times \text{PSI} \div 6.28 \\ \text{CIR} &= T \div \text{PSI} \times 6.28 \\ \text{PSI} &= T \times 6.28 \div \text{CIR}\end{aligned}$$

$$\begin{aligned}T &= (\text{GPM} \times \text{PSI} \times 36.77) \div 6.28 \\ \text{GPM} &= (T \div \text{PSI} \div 36.77) \times 6.28 \\ \text{PSI} &= (T \div \text{GPM} \div 36.77) \times 6.28\end{aligned}$$

Note:

Divide PSI by Mechanical Efficiency if required.
For Torque in foot-lbs use 75.36 in place of 6.28

T = Torque, inch-lbs
CIR = Cubic Inch (in³) per Revolution
GPM = Flow in gallons per minute
PSI = Pressure difference across motor
RPM = Pump revolutions per minute
HP = Horsepower

Torque General Info:

$$\text{Torque} = \text{Radius} \times \text{Load}$$

$$\text{Torque (in lbs)} = \text{Lever Length (in.)} \times \text{Pull (lbs.)}$$

$$\text{Radius} = 1/2 \text{ of Diameter}$$

$$\text{Circumference} = 3.14 \times \text{Diameter}$$

$$\text{Foot Pound} = \text{Inch Pound} \div 12$$

$$\text{Inch Pound} = \text{Foot Pound} \times 12$$

Motor Speed:

$$\begin{aligned}\text{GPM} &= \text{RPM} \times \text{CID} \div 231 \\ \text{RPM} &= \text{GPM} \times 231 \div \text{CID} \\ \text{CID} &= \text{GPM} \div \text{RPM} \times 231\end{aligned}$$

$$\text{Speed} = (336 \times \text{MPH}) \div \text{Wheel Diameter (in.)}$$

Side load on pump or motor shaft:

$$F = (\text{HP} \times 63024) \div (\text{RPM} \times R)$$

F = Side load, in pounds, against shaft
R = Pitch radius of sheave on pump shaft, in inches;
HP = Driving power applied to shaft.

Motor Efficiencies:

$$\text{Volumetric Efficiency} = \frac{\text{Actual Speed} \times 100}{\text{Theoretical Speed}}$$

$$\text{Mechanical Efficiency} = \frac{\text{Actual Torque} \times 100}{\text{Theoretical Torque}}$$

$$\text{Overall Efficiency} = \frac{\text{Output HP} \times 100}{\text{Input HP}}$$

$$\text{Overall Efficiency} = \text{Mech. Eff.} \times \text{Volumetric Eff.}$$

Theoretical Speed = GPM x 231 ÷ CIR
Theoretical Torque (in lbs) = CIR x PSI ÷ 6.28
Input HP = PSI x GPM ÷ 1714
Output HP = T x RPM ÷ 63025

T = Torque, inch-lbs
CIR = Cubic Inch (in³) per Revolution
GPM = Flow in gallons per minute
PSI = Pressure difference across motor
RPM = Pump revolutions per minute

Note:

For Torque in foot-lbs use 5252 in place of 63025

Draw Bar Pull, Moving a load up an incline:

$$F = L \times \sin$$

F = Force
W = Weight or load
sin = Sin of incline or angle

Rule of thumb:

Grades less than or equal to 10° use the degree of the angle. Grades greater than 10° use sin.

$$\text{Grade (\% of Slope)} = \text{Rise} \div \text{Run}$$

Draw Bar Pull, Friction:

$$F = W \times M$$

F = Force
W = Weight or load
M = Coefficient of friction

Draw Bar Pull, Moving a load up an incline with friction:

$$\begin{aligned}\text{F to move load} &= (W \times \sin) + (W \times \cos \times M) \\ \text{F to hold load} &= (W \times \sin) - (W \times \cos \times M)\end{aligned}$$

F = Force
W = Weight or load
M = Coefficient of friction
sin = Sin of incline or angle
cos = Cosine of incline or angle

Formulas

Velocity of oil flow in pipe:

$$V = \text{GPM} \times 0.3208 \div A$$

$$A = \text{GPM} \times 0.3208 \div V$$

$$\text{GPM} = A \times V \div 0.3208$$

V = Oil velocity in feet per second

GPM = Flow in gallons per minute

A = Inside area of pipe in square inches.

Rule of thumb:

Pump suction lines 2 to 4 feet/second

Pressure lines up to 500 PSI - 10 to 15 fps

Pressure lines 500 to 3000 PSI - 15 to 20 fps

Pressure lines over 3000 PSI - 25 fps

All oil lines in air-over-oil system - 4 fps

fps = feet per second

Barlow formula (hoop stress):

$$P = 2 \times t \times S \div D$$

P = Working pressure in PSI with a 4:1 Design Factor

t = Wall thickness, in inches

S = Allowable stress (12,500 with a 4:1 Design Factor)

D = Outside diameter, in inches.

$$D = \sqrt{A/.7854}$$

Atmosphere:

Atmospheric pressure is 14.7 psi at sea level

One Bar is equal to 14.5 psi (Atmos. - 1.01 Bar)

The pressure created by one foot of water is .433 psi

$$\text{Atmospheric Ratio} = 14.7 \div \text{PSI} = 33.9 \div (X)$$

Atmospheric will lift water 33.9 feet

1 inch Hg = .491 psi

14.7 psi = 29.92 hg

Y inch Hg Absolute = (29.92 - Y) x .491 = PSI

PSI = lbs \div in²

Hg = Inches of mercury

Filtration:

1 Micron = .000039"

149 Micron = 100 Mesh

74 Micron = 200 Mesh

44 Micron = 325 Mesh

Beta 75 = 98.7%

Beta 100 = 99%

Beta 200 = 99.5%Gas

Beta Ratio = Upstream Count \div Downstream Count

Efficiency Percent (%) = 1 - (1 \div Beta Ratio) x 100

Gas Formulas:

$$\text{PSIG (PSI Gage)} = \text{PSIA} - 14.7$$

$$\text{PSIA (PSI Absolute)} = \text{PSIG} + 14.7$$

Isothermal

$$P_1 \times V_1 = P_2 \times V_2$$

P₁ = Pre-charge Pressure + 14.7

V₁ = Initial Gas Volume

P₂ = System Pressure + 14.7

V₂ = Compressed Gas Volume

P₁, V₁ are initial pressure and volume; P₂ and V₂ are final conditions.

Note:

Isothermal operation occurs when compression or expansion is slow enough to allow transfer of heat out of or into the accumulator.

Adiabatic

$$P_1 \times V_1 \times T_2 = P_2 \times V_2 \times T_1$$

$$P_1 \times V_1 \div T_1 = P_2 \times V_2 \div T_2$$

P₁ = Pre-charge Pressure + 14.7

V₁ = Initial Gas Volume

P₂ = System Pressure + 14.7

V₂ = Compressed Gas Volume

T₁ = Initial Temp. Absolute (Rankine)

T₂ = Increased Temp. Absolute (Rankine)

T₁, P₁ and V₁ are initial temperature, pressure and volume and, T₂, P₂ and V₂ are final conditions.

Note:

Adiabatic operation occurs when compression or expansion is rapid so that there is no transfer of heat. The adiabatic equation is used where compression or expansion occurs in less than 1 minute.

Rule of thumb:

Compressibility of hydraulic oil: Volume reduction is approximately 0.5% for every 1000 PSI pressure.

Compressibility of water: Volume reduction is about 0.3% for every 1000 PSI pressure.

Rankine = Fahrenheit + 460

Kelvin = Celsius + 278

Celsius to Fahrenheit = (C + 17.78) x 1.8 = Fahrenheit

Fahrenheit to Celsius = F - 32 \div 1.8 = Celsius

Initial Gas Volume - Compressed **Gas** = Usual Oil

Formulas

Reservoir Cooling:

$$\text{HP Radiated} = \text{Sq. Ft.} \times \text{TD} \div 1000$$

$$\text{Sq. Ft.} = \text{HP} \times 1000 \div \text{TD}$$

$$\text{TD} = \text{HP} \times 1000 \div \text{Sq. Ft.}$$

HP = Power radiating capacity expressed in horsepower

Sq. Ft. = Surface area, in square feet

TD = Temperature difference (Delta) in °F between oil and surrounding air.

If the tank is half full, divide the answer by 2.

If the tank is stainless steel (CRES), divide the answer by 2.

If the tank is aluminum, multiply the answer by 2.8.

$$1 \text{ HP} = 2545 \text{ BTU}$$

$$1 \text{ HP} = 746 \text{ Watts}$$

BTU = the energy to raise one pound of water one degree Fahrenheit

Rule of thumb:

Each watt will raise the temperature of 1 gallon of oil by 1 °F per hour.

Reservoir Heating:

$$\text{BTU's to heat a reservoir} = \text{Oil volume (ft}^3\text{)} \times 62.4$$

$$\text{Specific Heat (.5)} \times \text{Specific Gravity (.89)} \times \text{Temp.}$$

$$\text{Delta (Differential)}$$

$$\text{BTU} \div 2545 = \text{HP per Hour}$$

$$\text{HP} \times 746 = \text{Watts}$$

Note:

The following applies to petroleum based hydraulic fluids.

Hydraulic oil serves as a lubricant and is practically non-compressible. It will compress approximately 0.5% at 1000 psi.

The weight of hydraulic oil may vary with a change in viscosity, however, 55 to 58 lbs/ft³ covers the viscosity range from 150 SUS to 900 SUS @ 100 degrees F.

Pressure at the bottom of a one foot column of oil will be approximately 0.4 psi.

To find the pressure at the bottom of any column of oil, multiply the height in feet by 0.4.

Atmospheric pressure equals 14.7 psia at sea level.

psia (pounds per square inch absolute).

Gauge readings to not include atmospheric pressure unless marked psia.

Energy Formulas:

$$1 \text{ Kw} = 1.3 \text{ hp}$$

$$1 \text{ hp} = 550 \text{ ft lbs/s}$$

$$\text{Hydraulic hp} = \text{gpm} \times \text{psi} \div 1714$$

$$\text{Torque (in lbs)} = \text{psi} \times \text{disp. (in}^3\text{/rev)} \div 6.28$$

$$\text{Torque (in lbs)} = \text{hp} \times 63025 \div \text{Rpm}$$

$$\text{hp} = \text{Torque (ft lbs)} \times \text{rpm} \div 5252$$

$$\text{Btu (per hour)} = \Delta\text{psi} \times \text{gpm} \times 1.5$$

Formulae in SI Metric Units

Familiar fluid power formulae in English units are shown in the left column. When the industry converts to SI (International) units, these formulae will take the form shown in the right column.

English Units

Metric Units

Torque, HP, Speed Relations in Hydraulic Pumps and Motors

$$T = HP \times 5252 \div RPM$$

$$HP = T \times RPM \div 5252$$

$$RPM = HP \times 5252 \div T$$

T = Torque, foot-lbs.

RPM = Speed, revs/min

HP = Horsepower

$$T = Kw \times 9543 \div RPM$$

$$Kw = T \times RPM \div 9543$$

$$RPM = Kw \times 9543 \div T$$

T = Torque, Nm (Newton-meters)

RPM = Speed, revs/min

Kw = Power in kilowatts

Hydraulic Power Flowing Through the Pipes

$$HP = PSI \times GPM \div 1714$$

HP = Horsepower

PSI = Gauge pressure, lbs/sq. inch

GPM = Flow, gallons per minute

$$Kw = Bars \times dm^3/min \div 600$$

Kw = Powers in kilowatts

Bars = System pressure

dm³/min = Flow, cu. dm/minute

Force Developed by an Air or Hydraulic Cylinder

$$T = A \times PSI$$

T = Force or thrust, in lbs.

A = Piston area, square inches

PSI = Gauge pressure, lbs/sq. inch

$$N = A \times Bars \times 10$$

N = Cylinder force in Newtons

A = Piston area, sq. centimeters

Bars = Gauge pressure

Travel Speed of a Hydraulic Cylinder Piston

$$S = V \div A$$

S = Travel speed, inches/minute

V = Vol. of oil to cyl., cu.in/min

A = Piston area, square inches

$$S = V \div 6A$$

S = Travel speed, meter/sec

V = Oil flow dm³/minute

A = Piston area, square centimeters

Barlow's Formula - Burst Pressure of Pipe & Tubing

$$P = 2t \times S \div O$$

P = Burst pressure, PSI

t = Pipe wall thickness, inches

S = Tensile str., pipe material, PSI

O = Outside diameter of pipe, inches

$$P = 2t \times S \div O$$

P = Burst pressure, bars

t = Pipe wall thickness, mm

S = Tensile str., pipe material, bars

O = Outside diameter of pipe, mm

Velocity of Oil Flow in Hydraulic Lines

$$V = GPM \times 0.3208 \div A$$

V = Velocity, feet per second

GPM = Oil flow, gallons/minute

A = Inside area of pipe, sq. inches

$$V = dm^3/min \div 6A$$

V = Oil velocity, meters/second

dm³/min = Oil flow, cu.dm/minute

A = Inside area of pipe, sq.cm.

Recommended Maximum Oil Velocity in Hydraulic Lines

fps = feet per second

Pump suction lines - 2 to 4 fps

Pres. lines to 500 PSI - 10 to 15 fps

Pres. lines to 3000 PSI - 15 to 20 fps

Pres. lines over 3000 PSI - 25 fps

Oil lines in air/oil system - 4 fps

mps = meters per second

Pump suction lines - .6 to 1.2 mps

Pres. lines to 350 bar - 3 to 4½ mps

Pres. lines to 200 bar - 4½ to 6 mps

Pres. lines over 200 bar - 7½ mps

Oil lines in air/oil system - 1¼ mps

Equivalent Values & U.S. / Metric Conversions

LENGTH

1 micron (μ) = 0.00004 inch (in.)
1 millimeter (mm) = 0.039 in.
1 centimeter (cm) = 0.3937 in.
1 decimeter (dm) = 0.3281 foot (ft.)
1 meter (m) = 39.37 in.
= 3.281 ft.
= 1.0937 yards (yds.)

AREA - SQUARE

1 square millimeter = 0.00155 square inch (sq. in.)
1 square centimeter = 0.155 sq. in.
1 square decimeter = 15.5 sq. in.
= 0.10764 square feet (sq. ft.)

AREA - CUBIC

1 cubic centimeter = 0.061 cubic inch (in.³)
= 0.0002642 U.S. liquid gallons
1 cubic decimeter = 61.023 in.³

LIQUID MEASURE

1 milliliter (ml) = 0.0338176 ounce (oz.)
1 deciliter (dl) = 3.381 oz.
1 liter (l) = 1.0569 quarts (qt.)
= 0.26417 gallon (gal.)
1 drop = 0.05 cubic centimeter (cc)
= 0.00169 oz.

WEIGHT

1 gram (g) = 0.0353 ounce (oz.)
1 kilogram (kg.) = 2.2046 pounds (lb.)
1 metric ton = 0.9842 U.S. ton

TEMPERATURE

$^{\circ}\text{Celsius} = 5/9 (^{\circ}\text{Fahrenheit} - 32)$

FLOW - LIQUID

1 liter/minute (lpm) = 0.2642 U.S. gallon/minute (gpm)

FORCE

1 Newton (N) = 0.225 pound (lb.)

FREQUENCY

1 cycle/second (cps) = 1 Hertz (H)

ABSOLUTE VISCOSITY

1 centipoise (@ 0.9 specific gravity) = 5.35 SUS

POWER

1 kilowatt (kw) = 1.34 horsepower (HP)
1 horsepower (HP) = 33,000 foot-pounds (ft. lbs.)/minute
= 550 foot-pounds (ft. lbs.)/second
= 42.4 BTU/minute
= 746 watts

PRESSURE

1 bar = 14.5 pounds per square inch (psi) — above atmospheric
= 33.8 foot water column
= 42 foot oil column
= 29.92 inches of mercury (in. Hg)
1 millimeter of mercury (mm Hg) = 0.03937 in. Hg — below atmospheric
1 psi = 2.0416 in. Hg
= 27.71 in. water
1 foot column of water = 0.433 psi
1 foot column of oil = 0.390 psi

TORQUE

1 Newton-meter (Nm) = 8.88 pound-inches (lb.-in.)

VELOCITY

1 meter per second (m/s) = 3.28 feet/second (fps)

Conversion Factor Tables

To convert	→	→	→	→	Into	→	→	→	→	→	Multiply by
Into	←	←	←	←	To convert	←	←	←	←	←	Divide by
Unit					Unit						Factor
Atmospheres	Atm	bar	bar	bar		1.01325
Atmospheres	Atm	inches of mercury	in Hg		29.92
Atmospheres	Atm	mm of mercury	mm Hg		760
Atmospheres	Atm	pounds/square inch	psi		14.7
bar	bar	pounds/square inch	psi		14.5
British thermal unit	Btu	calorie	cal		252
British thermal unit	Btu	joule	J		1054.35
British thermal unit	Btu	foot pounds	ft-lbs		777.65
British thermal unit/hr	Btu/hr	kilowatts	kW		0.000293071
centimetres	cm	inches	in		0.3937
centimetres per sec	cm/sec	feet per minute	ft/min		1.969
centimetres per sec	cm/sec	feet per second	ft/sec		0.03281
Celsius	°C	Fahrenheit	°F		(F-32) ÷ 1.8
centiStokes	cSt	Saybolt	SUS		4.635 (>52 cSt)
cubic centimetres	cm ³	cubic inches	in ³		0.06102
cubic feet	cu ft	gallons US	US gal		7.481
cubic feet	cu ft	cubic metres	m ³		0.0283168
cubic inches	in ³	cubic centimetres	cm ³		16.3871
cubic inches	in ³	gallons US	US gal		0.004329
cubic yards	yd ³	cubic metres	m ³		0.7646
degrees	(angle)	°radians	rad		0.0174533
Fahrenheit	°F	Celsius	°C		(C x 1.8) + 32
feet	ft	metres	m		0.3048
feet of water	ft H ₂ O	bar	bar		0.0298907
feet of water	ft H ₂ O	pounds/square inch	psi		0.4335
feet of water	ft H ₂ O	inches of mercury	in Hg		0.8826
feet of oil (sg = 0.87)	pounds/square inch	psi		0.377
feet of oil (sg = 0.87)	inches of mercury	in Hg		0.768
feet per minute	ft/min	centimetres per sec	cm/sec		0.5080
feet per second	ft/sec	centimetres per sec	cm/sec		30.48
feet per minute	ft/min	miles per hour	mph		0.01136
feet per second	ft/sec	miles per hour	mph		0.6818
fluid ounces UK	UK fl oz	cubic centimetres	cm ³		28.413
fluid ounces US	US fl oz	cubic centimetres	cm ³		29.5735
foot pounds per min	ft-lbs/min	horsepower	hp		0.0003030
foot pounds per sec	ft-lbs/sec	horsepower	hp		0.001818
foot pounds per min	ft-lbs/min	watts	W		81.3492
foot pound	ft-lb	kilogram metre	kgm		0.1383
foot pound	ft-lb	Newton metre	Nm		0.1356
foot pound	ft-lb	joule	J		1.35582
gallons US	US gal	cubic inches	in ³		231
gallons US	US gal	gallons UK	UK gal		0.8327
gallons US	US gal	litres	l		3.78531
gallons US	US gal	cubic feet	cu ft		0.1337
gallons UK	UK gal	litres	l		4.54596
gallons UK	UK gal	gallons US	US gal		1.201
horsepower	hp	British thermal unit/min	Btu/min		42.44
horsepower	hp	foot pounds per min	ft-lbs/min		33
horsepower	hp	foot pounds per sec	ft-lbs/sec		550
horsepower	hp	kilowatts	kW		0.7457
horsepower	hp	Pferde Starke	PS		1.014
horsepower	hp	poncelet		0.7604

Conversion Factor Tables

To convert	→	→	→	→	Into	→	→	→	→	→	Multiply by
Into	←	←	←	←	To convert	←	←	←	←	←	Divide by
Unit					Unit						Factor
inches				in	centimetres				cm		2.54
inches				in	millimetres				mm		25.4
inch pounds				in-lbs	kilogram/metre				kgm		0.01152
inch pounds				in-lbs	Newton metre				Nm		0.1130
inches of mercury				in Hg	Pascal				Pa		3386 (32° F)
inches of mercury				in Hg	pounds/square inch				psi		0.4912
inches of mercury				in Hg	millibar				mbar		33.8639
kilogram				kg	pound				lb		2.205
kilogram				kg	Newton				N		9.80665
kilogram metre				kgm	Newton metre				Nm		9.80665
kilogram metre				kgm	inch pounds				in-lbs		86.80
kilogram metre				kgm	foot pound				ft-lb		7.233
kilogram per square centimetre				kg/cm ²	bar				bar		0.980665
kilopascals				kPa	bar				bar		0.01
kilometres				km	miles						0.6214
kilometres				km	feet				ft		3281
litres				l	gallons UK				UK gal		0.2199
litres				l	gallons US				US gal		0.2642
metric horse power					kilowatts				kW		0.735499
microinches				min	microns				mm		0.0254
miles					kilometres				km		1.609
millimetres mercury				mm Hg	millibar				mbar		1.33322
Newton				N	pound				lb		0.2248
Newton metre				Nm	foot pound				ft-lb		0.7376
Newton metre				Nm	inch pounds				in-lbs		8.851
Newtons per square centimetre				N/cm ²	bar				bar		0.1
Newtons per square metre				N/m ²	bar				bar		0.00001
Pascals				Pa	bar				bar		0.00001
pint UK				UK pt	litres				l		0.568245
pint US				US pt	litres				l		0.473163
pounds				lb	grams				g		453.6
pounds				lb	Newton				N		4.448
pounds/square inch				psi	Atmospheres				Atm		0.06804
pounds/square inch				psi	bar				bar		0.06895
pounds/square inch				psi	inches of mercury				in Hg		2.036
pounds/square inch				psi	feet of water				ft H ₂ O		2.307
pounds/square inch				psi	feet of oil (sg=0.87)						2.65
pounds/cubic foot				lb-ft ³	Kilograms/cubic metre				kg-m ³		16.02
square inches				in ²	square centimetres				cm ²		6.5416
square feet				ft ²	square metres				m ²		0.09290304
Saybolt				SUS	centiStokes				cSt		See below
32 – 99 SUS					cSt = 0.2253 x SUS – (194.4 ÷ SUS)						
100 – 240 SUS					cSt = 0.2193 x SUS – (134.6 ÷ SUS)						
>240 SUS					cSt = SUS ÷ 4.635						

Troubleshooting Hints

Troubleshooting Hints:

Many of the failures in a hydraulic system show similar symptoms: a gradual or sudden loss of pressure or flow, resulting in loss of power or speed in the cylinders or hydraulic motors. In fact, the cylinders may stall under light loads or may not move at all. Often the loss of power is accompanied by an increase in pump noise, especially as the pump tries to build up pressure.

Any one of the system's components - pump, relief valve, directional valve, or cylinder could be at fault.

By following an organized step-by-step testing procedure, the problem can be traced to a general area, then if necessary, each component in that area can be tested, repaired or replaced.

Familiarize yourself with the circuitry of the hydraulic system to be tested. Review of the Service Manual is critical to learn the circuitry and location of various components: reservoir, hydraulic pump, relief valve, control valves, cylinders and hydraulic motors. The Service Manual should also provide operating specifications on fluid temperature, relief valve setting and pump delivery at specific RPMs.

Check the obvious. Is there sufficient fluid in the reservoir? Is it dirty? Is the filtering system in proper condition? Are there any bent linkages or pinched hoses? Are quick couplers functioning properly?

Before you start troubleshooting a system, it is helpful to ask questions and find out about the problem:

1. Has the system been working fine and then it just quit and stopped working?
2. Has the system been working fine and then it started to slowly change in the way it works?
3. Does the system work fine when first started and then changes as it is used and as the system heats up?
4. Did the system stop working after something else was fixed or replaced?
5. Did the system ever work or work properly after it was assembled?

When troubleshooting a hydraulic system there are a few tools which will aid in finding and repairing a problem.

1. Pressure Gauge; To measure the System Pressure (P.S.I.).
2. Flow Meter; To measure Gallons per Minute (G.P.M.).
3. Temperature Gauge; To measure Heat.
4. Needle Valve; To Load / Restrict the System being tested.
5. And Your Senses;
 - A. Seeing; Is that suppose to be BENT?
 - B. Hearing; Is it suppose to be that LOUD?
 - C. Smell; Is it suppose to SMELL BURNT?
 - D. Touch; I can't it's too HOT!
 - E. Common; Do I want to get in there while it's WORKING? I DONT THINK SO!

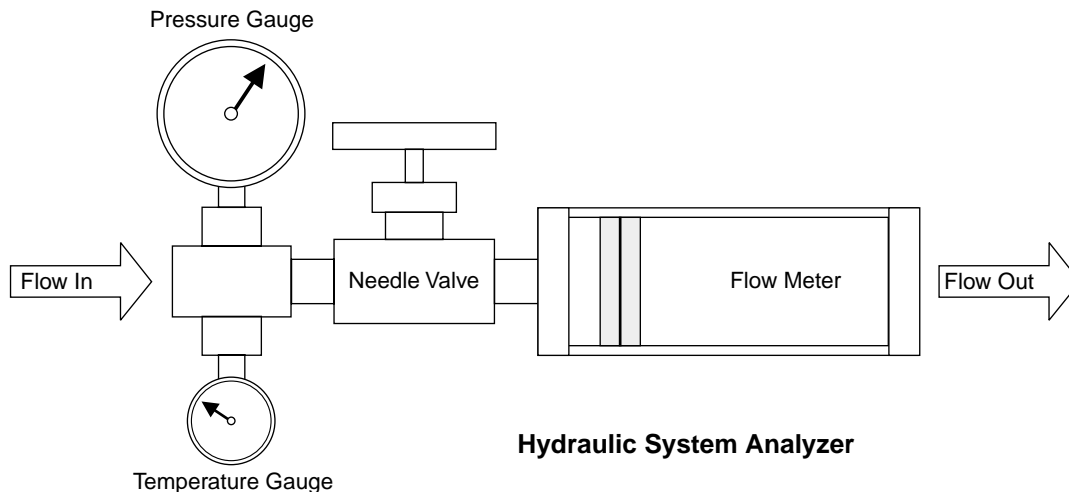

With items 1, 2, 3, 4, and the necessary fittings and hoses, a Hydraulic System Analyzer can be built and most hydraulic system problems can be diagnosed and repaired.

Make sure the items are sized properly for the system being tested, don't use a 200 PSI Gauge in a 3000 PSI System or a 5 GPM Flow Meter or Needle Valve in a 50 GPM System. Verify and make sure that all the components are rated at, or exceed the pressures and flows being tested.

Troubleshooting Hints

A Hydraulic Analyzer can be used to check the following:

- 1. Fluid Temperatures, using the temperature gauge provided.** Fluid should be flowing through the analyzer for several minutes to obtain an accurate reading.
- 2. Flow rates, using the flow meter provided.** With the needle valve wide open, the monitor will show the rate at minimum pressure loss. The flow rate can be restricted by turning in on the needle valve from wide open to show the flow at various pressure loads.
- 3. System or operating pressure, by referring to the pressure gauge.** To prevent possible component damage, always be sure the needle valve on your analyzer is in the wide open position prior to starting system and if possible, have a relief valve between pump and analyzer.

Example Test for Hydraulic Pump Performance:

1. With system off and needle valve on analyzer in wide open position, install the analyzer in the line with fluid to be flowing in the direction of the arrow on the flow monitor scale.
2. Tighten all fittings to prevent unnecessary leakage.
3. Allow fluid to flow through the analyzer by turning on system.
4. Check the system Service Manual to see what specifications the pump is rated at. Example: 15 gpm @ 1500 psi.
5. With full flow flowing through the analyzer, start turning in the analyzer needle valve, gradually restricting the flow and at the same time, increasing pressure load on the pump. When reaching the rated pressure of the system pump, determine if the pump is operating efficiently (proper flow rate) or if it may need replacing or rebuilding. If the system relief valve is set below test pressure, the relief may have to be increased slightly to test the pump. Be sure to turn the relief valve back to its previous setting when tests have been completed.

Troubleshooting Heated Fluid:

When analyzing a hydraulic system in which the fluid temperature is higher than normal, it should be kept in mind that hot fluid can produce unusual flow and operating characteristics. A flow monitor with a minimal sensitivity to temperature variation should be used. When fluid gets hot, the viscosity decreases (the fluid gets much thinner). This thinner fluid can pass through much smaller openings or, in other words, more fluid will pass through the same original opening.

When the System Heats Up:

1. Pumps usually slip more fluid through standard clearances. High pressure settings usually cannot be obtained.
2. When the fluid thins down, the parts run closer together and wear faster. Particles of dirt which may not have been a problem with thicker fluid may now be very damaging.
3. Valves, cylinders and actuators will slip more fluid through standard clearances.

All-in-all, excessive heat in a system will not only cause excessive and faster wear, but the system will seem very sluggish because of the lack of fluid supply and operating pressure.

Knowing the potential of your analyzer, the effects of fluid temperature and pressure drop will always insure confidence in analyzing and troubleshooting any service problem areas. The analyzer is only as good as the operator and the less complicated the unit, the more it will be used.

Troubleshooting Hints

Basic Troubleshooting Steps:

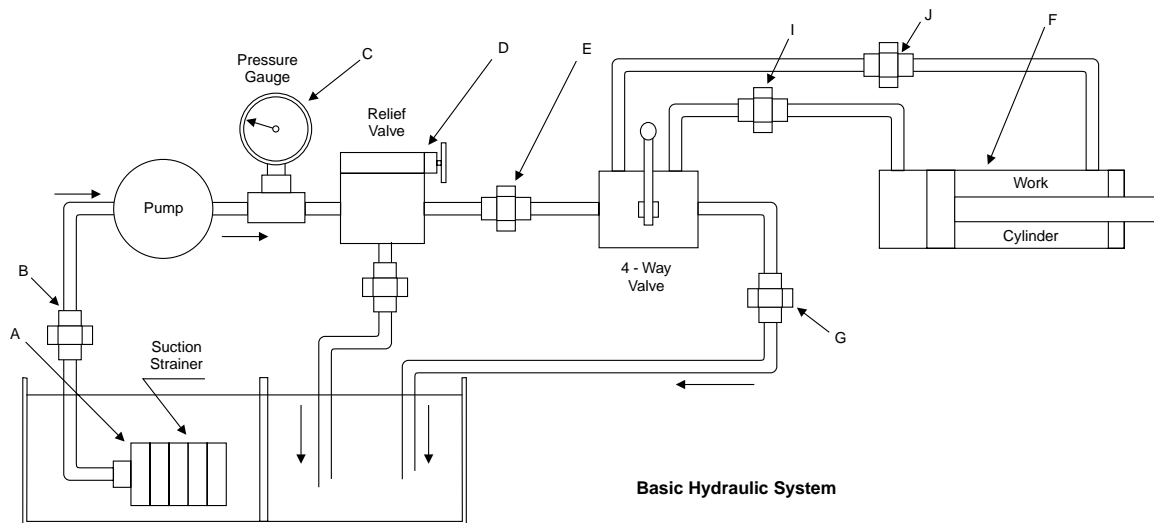

Step 1 - Pump Suction Strainer...

Probably the field trouble encountered most often is cavitation of the hydraulic pump inlet caused by restriction due to a dirt build-up on the suction strainer. This can happen on a new as well as on an older system. It produces systems such as: increased pump noise, loss of high pressure and / or speed.

If the strainer is not located in the pump suction line it will be found immersed below the oil level in the reservoir, as at Point A. Some operators of hydraulic equipment never give the equipment any attention or maintenance until it fails. Under these conditions, sooner or later, the suction strainer will probably become sufficiently restricted to cause a breakdown of the whole system and damage to the pump.

The suction strainer should be removed for inspection and should be cleaned before reinstallation. Wire mesh strainers can best be cleaned with an air hose, blowing from inside out. They can also be washed in a solvent which is compatible with the reservoir fluid. Kerosene may be used for strainers operating in petroleum based fluid. Do not use gasoline or other explosive or flammable solvents. The strainer should be cleaned even though it may not appear to be dirty. Some clogging materials cannot be seen except by close inspection. If there are holes in the mesh or if there is mechanical damage, the strainer should be replaced.

When reinstalling the strainer, inspect all joints, as at Point B for possible air leaks, particularly at union joints. There must be no air leaks in the suction line. Check the reservoir oil level to be sure it covers the top of the strainer by at least 3" at minimum oil level, which is with all cylinders extended. If it does not cover to this depth there is danger of a vortex forming which may allow air to enter the system when the pump is running.

Step 2 - Pump and Relief Valve...

If cleaning the pump suction strainer does not correct the trouble, isolate the pump and relief valve from the rest of the circuit by disconnecting at Point E so that only the pump, relief valve, and pressure gauge remain in the pump circuit. Cap or plug both ends of the plumbing which was disconnected. The pump is now deadheaded into the relief valve. Back out relief valve pressure adjustment. Start the pump and watch for pressure buildup on the gauge while tightening the adjustment on the relief valve. If full pressure can be developed, obviously the pump and relief valve are operating correctly, and the trouble is to be found further down the line. If full pressure cannot be developed in this test, continue with Step 3.

Step 3 - Pump or Relief Valve?...

If high pressure cannot be obtained in Step 2 by running the pump against the relief valve, further testing must be conducted to see whether the fault lies in the pump or in the relief valve. Proceed as follows:

If possible, disconnect the reservoir return line from the relief valve at Point H. Attach a short length of hose to the relief valve outlet. Hold the open end of this hose over the reservoir filler opening so the rate of oil flow can be observed. Start the pump and run the relief valve adjustment up and down while observing the flow through the hose. If the pump is bad, there will probably be a full stream of oil when relief valve adjustment is backed off, but this flow will diminish or stop as the adjustment is increased. If a flowmeter is available, the flow can be measured and compared with the pump catalog rating.

Troubleshooting Hints

If a flowmeter is not available, the rate of flow on small pumps can be measured by discharging the hose into a bucket while timing with the sweep hand on a watch. For example, if a volume of 10 gallons is collected in 15 seconds, the pumping rate is 40 GPM, etc.

If the gauge pressure does not rise above a low value, say 100 PSI, and if the volume of flow does not substantially decrease as the relief valve adjustment is tightened, the relief valve is probably at fault, and should be cleaned or replaced as instructed in Step 5.

If the oil flow substantially decreases as the relief valve adjustment is tightened, and if only a low or moderate pressure can be developed, this indicates trouble in the pump. Proceed to Step 4.

Step 4 - Pump...

If a full stream of oil is not obtained in Step 3, or if the stream diminishes as the relief valve adjustment is tightened, the pump is probably at fault. Assuming that the suction strainer has already been cleaned and the inlet plumbing has been examined for air leaks, as in Step 1, the oil is slipping across the pumping elements inside the pump. This can mean a worn-out pump, or too high an oil temperature. High slippage in the pump will cause the pump to run considerably hotter than the oil reservoir temperature. In normal operation, with a good pump, the pump case will probably run about 20° F above the reservoir temperature. If greater than this, excess slippage, caused by wear, may be the cause.

Check also for slipping belts, sheared shaft pin or key, broken shaft, broken coupling, or loosened set screw.

Step 5 - Relief Valve...

If the test of Step 3 has indicated the trouble to be in the relief valve, D, the quickest remedy is to replace the valve with another one known to be good. The faulty valve may later be disassembled for inspection and cleaning. Pilot operated relief valves have small orifices which may be blocked with accumulations of dirt. Blow out all passages with an air hose and run a small wire through orifices. Check also for free movement of the spool. In a relief valve with pipe connections in the body, the spool may bind if pipe fittings are over tightened. If possible, test the spool for bind before unscrewing threaded connections from the body, or, screw in fittings tightly during inspection of the valve.

Step 6 - Cylinder...

If the pump will deliver full pressure when operating across relief valve in Step 2, both pump and relief valve can be considered good, and the trouble is further downstream. The cylinder should be tested first for worn out or defective seals.

Run the cylinder to one end of its stroke. Disconnect the fluid line which was allowing oil to exhaust from the cylinder. Plug or cap the valve side of this disconnected line to avoid oil spillage caused by any back pressure in the tank return line. Attach a hose to the cylinder fitting where the fluid line was disconnected. Place open end of attached hose into a barrel or bucket. Start the pump and activate the valve to continue to stroke the cylinder the same direction. With the cylinder at the end of its stroke, check for any oil flowing from hose into barrel. If flow is excessive the cylinder may need repaired or replaced. Pistons with metal rings can be expected to have a small amount of leakage across the rings, and even those "leaktight" soft seals may have a small bypass during break in of new seals or after the seals are well worn. After checking, reinstall the lines and run the piston to the opposite end of the barrel and repeat the test. Occasionally a cylinder will leak at one point in its stroke due to a scratch or dent in the barrel. Check suspected positions in mid stroke by installing a positive stop at the suspected position and run the piston rod against it for testing. Once in a great while a piston seal may leak intermittently. This is usually caused by a soft packing or O-ring moving slightly or rolling into different positions on the piston, and is more likely to happen on cylinders of large bore.

Step 7 - Directional Control Valve...

If the cylinder has been tested (Step 6) and found to have reasonably tight piston seals, the 4-way valve should be checked next. Although it does not often happen, an excessively worn valve spool can slip enough oil to prevent build-up of maximum pressure. Symptoms of this condition are a loss of cylinder speed together with difficulty in building up to full pressure even with the relief valve adjusted to a high setting. This condition would be more likely to occur with high pressure pumps of low volume output, and would develop gradually over a long period of time.

Other Components

Check other components such as by-pass flow controls, hydraulic motors, etc. Solenoid 4-way valves of the pilot operated type with tandem or open center spools may not have sufficient pilot pressure to shift the spool.

System Inoperative:

1. Insufficient or No fluid in system.

Refill system with proper grade and type of fluid.
Filter new oil being added as recommended.
Refill oil reservoir with cylinders in closed position.
If refilled while cylinders are extended the reservoir may over flow when or as the cylinders retract.
Check for leaks.

2. Pump is not engaged.

Is pump shaft turning?
Check if PTO (power take off) is engaged.
Variable control mechanism out of adjustment.
Adjust to machine service manual specifications.

3. Slipping or broken pump drive.

Check pump drive mechanism (drive key, flex coupler) for damage.
Check for proper alignment or tension.

4. Pump inlet line plugged.

Drain oil and replace filter or filter element.
Check for clogged oil strainers.
Oil lines dirty or collapsed.
Check if correct inlet hose is used, inner liner may be collapsed.
Never use a pressure type hose as a pump inlet suction hose.
Check if supply shut off or gate valve is closed.
Check in reservoir for other possible obstructions.

5. Pump speed too slow.

Check minimum drive speed.
May be too slow to prime pump.

6. Wrong fluid in system.

Oil viscosity too heavy for pump to pick up a prime.
Drain complete system. Add new fluid of proper viscosity.

7. Air leaks at intake. Pump not priming.

Circuit must be tested at inlet connections.
At pump intake piping joints, test by pouring oil on joints while listening for a change in sound of operation.
Determine where air is being drawn into line connection and tighten.
At pump shaft, Test by pouring oil on shaft seal while listening for a change in sound of operation.
Follow manufacturer's recommendation when changing seals.

Air drawn in through intake pipe opening.
Check to be certain suction and return lines are well below oil level in reservoir. Add oil to reservoir if necessary.

7. Worn or dirty pump.

Clean, repair or replace.
Check alignment.
Check for contaminated oil.
Drain and flush system.

8. Pump driven in wrong direction of rotation.

Most pump assemblies will have an arrow showing correct rotation.

On gear type pumps, the pressure port / output will be on the side where the gears come together and mesh.

Check to assure correct pump rotation was applied during assembly.

9. Leakage.

Check all components, particularly the relief valve for proper settings.
Refer to technical manuals.

10. Broken or badly worn components (pump, valves, cylinders, etc.).

Examine and test for internal or external leakage.
Analyze the conditions that brought on the failure and correct them.

Repair or replace the faulty components according to technical manual specifications.

11. Excessive load.

Check unit specifications for load limits.

System Develops No Pressure:

1. Pump not delivering fluid.

Follow the remedies mentioned above.

2. Incorrect valve position or setting.

Check and engage valve.
Install pressure gauge and adjust to correct pressure.

3. Vanes in vane pump sticking.

Check for burrs or metal particles that might hold vanes in their slots.

Repair or replace if necessary.

Clean system if contaminants are found.

4. Fluid recirculating back to reservoir and not going to functions.

Mechanical failure of some other part of the system, especially a relief valve.

If contamination is involved, clean and refill with proper fluid.

5. Piston pump or valve broken, or stuck open allowing fluid to return to inlet side.

Disassemble the pump, determine the cause and correct it.

Repair according to technical manual instructions.

System Operates Erratically:

1. Air in system.

Check suction side for leaks. Repair.

2. Cold oil.

Allow ample warm-up period.

Operate only at recommended operating temperature ranges.

3. Wrong fluid viscosity.

Oil viscosity too heavy.

Drain complete system. Add new fluid of proper viscosity.

Troubleshooting Hints

4. Pump speed too slow.

Increase engine speed.
Check manual for recommendations.

5. Dirty or damaged components.

Clean or repair as necessary.

6. Restriction in filters or lines.

Clean and/or replace elements or lines.

7. Internal pump parts are sticking.

Dismantle and repair according to technical manual instructions.

Look for burrs on parts or metal particles in fluid.

If contaminants are the cause, clean and refill with proper fluid.

8. Distance between internal parts has increased due to wear.

Dismantle and repair.

If wear is abnormal, determine the cause by checking the operation and maintenance records as well as by examining the pump and system.

System Operates Slowly:

1. Oil viscosity too high, cold oil.

Allow oil to warm up before operating machine.

2. Low pump drive speed.

Increase engine speed (check manual for recommendations).

If clutch or belt-driven, check for proper tension.

3. Low oil level.

Check reservoir and add oil as necessary.

4. Air in system.

Check suction side for leaks. repair.

5. Badly worn pump, valves, cylinders, etc.

Repair or replace as needed.

6. Restriction in filters or lines.

Clean and/or replace elements or lines.

7. Improper adjustments.

Check orifices, relief, unloading, flow control valves, etc.

Adjust per manual.

8. Oil leaks.

Tighten fittings, replace seals or damaged lines.

System Operates Too Fast:

1. Wrong size or incorrectly adjusted restrictor or flow control.

Replace or adjust as necessary.

2. Engine running too fast.

Reduce engine speed.

Overheating of Oil in System:

1. Oil passing thru relief valve for excessive time.

Return control valve to neutral when not in use.

System stalling under load, etc.

Fluid viscosity too high.

2. Relief or unloading valve set too high.

Install pressure gauge and adjust to correct pressure.

3. Incorrect oil, low oil, dirty oil.

Use recommended oil, fill reservoir, clean oil, replace filter element.

4. Engine running too fast.

Reduce engine speed.

5. Excessive component internal leakage.

Check stall leakage past pump, valve, motor, cylinder or other components.

Repair or replace component as necessary.

6. Restriction in filters or lines.

Check if line I.D.'s are too small causing high velocity.

Check if valvings too small, causing high velocity.

Clean and/or replace elements or lines.

7. Malfunctioning oil cooler / heat exchanger.

Check if water is shut off, if water cooled.

Check for clogging.

Clean repair.

8. Insufficient heat radiation.

Check for proper air circulation around reservoir.

Ambient temperature too high for system design.

Clean dirt and mud from reservoir and components.

9. Reservoir sized too small.

Increase reservoir size.

Add oil cooler or heat exchanger.

10. Reservoir assembled without or insufficient baffling.

Add baffling to allow fluid time to cool.

Foaming of Oil:

1. Incorrect oil, low oil, dirty oil.

Replace, clean or add as needed.

2. Air leaks.

Check suction line and component seals for suction leaks. Repair or replace.

3. Return of tank line not below fluid level.

Repair or replace.

4. Inadequate baffles in reservoir.

5. Lack of anti-foaming additives in oil.

Replace fluid with proper grade.

Troubleshooting Hints

Noisy Pump:

- 1. Air leak in intake, or air is being drawn through the inlet line.**
Repair or make sure the inlet line is submerged in fluid in the reservoir.
To check for leaks, pour fluid around the joints and listen for a change in sound of operation.
- 2. Low oil level, incorrect oil, foamy oil.**
Check if oil viscosity too high or operating temperature too low.
Replace, clean or add proper grade and type of fluid as needed.
With rare exception all return lines should be below fluid level in reservoir
- 3. Pump inlet line or inlet screen is restricted or clogged.**
Clean or replace as needed.
- 4. Reservoir breather vent clogged.**
Clean or replace as needed.
- 5. Worn or damaged pump.**
Check and correct cause of parts failure.
Repair or replace as needed.
- 6. Pump speed too fast.**
Operate pump within recommended speed.
- 7. Drive coupling mis-aligned.**
Align unit and check condition of seals and bearings.
Misalignment will cause wear and subsequent high noise level in operation.
- 8. Relief or unloading valve set too high.**
Use reliable gauge to check operating pressure.
Relief valve may have been set too high with a damaged pressure gauge.
Check unloading devices to see that they are properly controlling the pump delivery.

Excessive Pump Wear:

- 1. Abrasive contaminants or sludge in the fluid.**
Check for the cause of contaminants.
Replace or repair worn parts according to service manual.
Install or change fluid filter.
Replace fluid with recommended grade and quality.
- 2. Viscosity of fluid too low or too high.**
Replace fluid with proper grade and type.
- 3. Sustained high pressure above maximum pump rating.**
Check for possible relief valve malfunction or other parts failure.
- 4. Air leaks or restriction in system causing cavitation.**
Eliminate any leaks in system.
- 5. Drive shaft misaligned.**
Check and correct according to technical manual specifications.

Leaky Pump or Motor:

- 1. Damaged or worn shaft seal.**
Check and replace.
Check for misalignment.
Check that chemicals in fluid are not destroying packing or seals
- 2. Loose or damaged parts.**
Tighten or replace.

Internal Pump Parts Breakage:

- 1. Excessive pressure above maximum limits for pump.**
Check for parts malfunction and cause.
Repair according to machine technical manual.
- 2. Seizure due to lack of fluid.**
Check reservoir fluid level, as well as fluid inlet line for restriction.
Check for plugged inlet filter or strainer.
- 3. Abrasive contaminants in fluid are getting past the filter.**
Check for plugged inlet filter or strainer.
Check for malfunctioning filter bypass valve.
- 4. Excessive torquing of housing bolts.**
Replace damaged parts.
Torque to proper specifications.

Load Drops with Control Valve in Neutral:

- 1. Leaking cylinder seals or fittings.**
Replace worn parts.
- 2. Control valve not centering when released.**
Check linkage.
Check spool for binding.

Control Valve Sticking (Binding):

- 1. Valve linkage misaligned.**
Repair.
- 2. Tie-bolts too tight (stack valves).**
Loosen and retighten as necessary.
- 3. Valve damaged.**
Repair or replace.

Control Valve Leaks:

- 1. Tie-bolts too loose (stack valves).**
Tighten as necessary.
- 2. Seals damaged or worn.**
Replace.

Relief Valve Noisy:

- 1. Relief valve setting too close to operating pressure.**
Install pressure gauge and adjust to correct pressure.
- 2. Worn or scored poppet and seat.**
Replace.
- 3. Spring in relief valve broken.**
Replace spring and adjust to correct pressure.

Cylinder Seal Leakage:

1. Slow, Uniform Leakage:

- A. Poor low-pressure sealability (especially if a lip seal).
- B. Too little initial interference (if squeeze-type seal).
- C. Loss of interference or squeeze due to wear or compression set.
- D. Seal shrinkage after installation (possibly chemically induced, or a result of leaching of plasticizers by solvent action).
- E. Possible omission or failure of static seal(s).
- F. Microscopic debris lodges under seal lip (lint, fiber, etc.).
- G. Scored lip due to passage of sharp particle under seal, leaving cut or nick.
- H. Seal lip is nicked or cut during installation (note whether leak starts immediately after seal installation).
- I. Non-repetitive overheating hardens compound (which loses its ability to conform to dynamic surface deviations).
- J. Off-center alignment puts all clearance on one side, all compression on the other (due to bearing wear, excessive side loads, etc.).
- K. Check *static* surfaces of dynamic seal (groove surfaces). They may have problems F, G, or H hidden from view, and without self-cleaning tendency.

2. Gradually Increasing Leakage:

- A. Progressive wear.
- B. Increasing compression set.
- C. Progressive tear or erosion from initial nick.
- D. Fine score mark on dynamic surface progressively abrades seal lip.

3. Sudden Copious Leakage:

- A. Extruded seal.
- B. Torn seal lip (see 1-D, -E, -F, -G, -H, & -I, and 2-D).
- C. Twisted seal.
- D. Dramatic bearing failure due to excessive side load, shock, etc.
- E. Spiral failure.
- F. Massive infusion of contamination (due to incorrect fluid added to system, or to upstream introduction of dirt or wear debris).
- G. Slow rod leakage builds up behind tight wiper, then dumps . . . giving *appearance* of catastrophic seal failure. If leak rate continues, look for slow leak or erratic leak causes. If high leak rate continues, look for true catastrophic leak origin.
- H. Reverse-pressure blowout of piston seal due to pressure trap or failure of opposed seal.

4. Erratic (start-stop) Leakage:

- A. Cold start-up shrinks seal; friction/fluid heating restores size.
- B. Intermittent eccentric loading.
- C. Fibrous contamination working its way past seal lips.
- D. Unstable seal (twists and returns, cocks, etc.) *usually* caused by shock loading.
- E. Rod seal leaks slowly, tight wiper periodically dumps accumulated leakage (see 3-G).
- F. Fluid viscosity changes as temperature cycles (e.g., forklift truck alternately entering and leaving cold storage area).

5. Stick-slip Operation:

- A. Worn-away, low friction surface treatment.
- B. Breakdown of fluid lubricity due to contamination or deterioration of fluid.
- C. Viscosity change due to temperature.
- D. Excessive burnishing of dynamic surface to finer finish destroys ability of surface to maintain lube film (e.g., may go from 12 RMS to 4 RMS).

6. Seizing:

- A. Seal and bearing swell due to incompatible fluid and compound (possibly running hotter than temperature at which fluid is compatible).
- B. Thermal expansion of compound.
- C. Pressure trap between dual squeeze seals or incorrectly installed lip seals.
- D. Wedging of seal or backup device into extrusion gap (if used, it is usually the backup device that extrudes).
- E. In low-pressure systems, shock or other factors cock, cant or misorient the seals in grooves.
- F. Bent rod, cocked head, etc.

7. Scored Rod or Ram:

- A. Internally generated contamination.
- B. Externally introduced rod dirt, dirty makeup or disassembly/ reassembly dirt.
- C. Misoriented exclusion devices (wiper/scraper); eccentric installation.
- D. Misaligned (eccentric) loads cock ram into metal-to-metal contact with head.
- E. Wiper in vertical ram forms catch-all pocket.

8. Drift:

- A. Inspect valve for leakage and full closure *before* disassembly. (disconnect return line on valve and inspect visually for leakage).
- B. See problems 1 and 2 as applied to piston seals.
- C. Misapplied cast-iron rings in a "hold" cylinder (right ring in the wrong job).
- D. In "retract-mode" creep, check rod seal as well as piston seal.
- E. Static internal seal may provide leakage path past piston.

9. Increasing Cylinder Drag:

- A. Seal swell caused by improper (incompatible) *installation* lubricant (e.g., EPR seal lubed with petro-based grease or oil).
- B. Packing of contaminants into wiper groove of vertical ram.
- C. Thermal expansion of bearings and/or seals.
- D. Apparent drag increase due to undetected flow restriction in supply or return line . . . or bypassing of pressure though improperly closing valve . . . or obstructed check valve, etc.
- E. Cocked or twisted seal bypassing fluid and wedging into extrusion gap.

10. Increasing Cylinder/Rod Temperature:

- A. See causes for problem 9. In their earlier stages, these problems may appear as hotter-running cylinders.
- B. Internal leakage "throttling" past seal can cause rapid heating.
- C. Decreased lubricity of fluid can boost friction and heating (hotter fluid has lower viscosity, etc.). Contaminated or deteriorated fluid can cause same cycle.
- D. Diluted fluid can boost friction, etc.
- E. Condensation in reservoirs can emulsify or hit cylinder as slugs of fluid with near-zero lubricity. Also, hot water can *swell* compounds such as urethanes, increasing friction.

11. Telescopic sleeve undersized, out of round or bulged.

- A. Check with micrometers to see if sleeve/tube is within specifications.

Cylinder will not Operate or Move:

1. **Pump or PTO is not engaged, system not receiving fluid.**
Engage pump, correct pump flow problem.
2. **Control valve not engaged.**
Engage valve, check for linkage alignment and damage.
3. **Pressure too low.**
Check pressure at cylinder to make sure it is to circuit requirements.
4. **Cylinder bypassing internally.**
Check for internal scoring, damaged or worn seals, internal cracks.
5. **Cylinder overloaded for rated capacity.**
Reduce load.
6. **Cylinder too small or not rated for application.**
Install correct cylinder.
7. **Piston rod broken at piston end.**
Disassemble and replace piston rod.
8. **Hose quick disconnect not attached.**
Check if hose quick disconnect is connected properly.

Cylinder not Holding Load or Drifts:

1. Cylinder bypassing internally.

Check for internal scoring, damaged or worn seals, internal cracks.

Pressurize one side of cylinder and disconnect fluid line at opposite port. Observe leakage. One to three cubic inches per minute is considered normal for piston rings. Virtually no leak with soft seals on piston. Replace cylinder barrel or seals as required.

2. Other circuit leaks.

Check for leaks thru operating valve and correct. Correct leaks in connecting lines.

3. Incorrect Valving.

Open center valve with conventional single rod cylinder will creep if restriction on tank port is sufficiently high. Use tandem type valve spool configuration or spool with pump dumped through one cylinder port with the other blocked.

Closed center valve can cause similar results except creep will be according to amount of clearance flow in the valve. Proper notching of valve spool can prevent building up pressure in cylinder lines between cycles.

Spools with pressure blocked and cylinder ports completely relaxed will also prevent drift if no moving element is not affected by gravity or vibration.

Pilot operated check valves can positively lock fluid in cylinder lines. Care must be exercised to insure adequate pilot pressure when rod differential may cause intensification.

Cylinder operates erratically or chatters:

1. Telescopic cylinder sleeves mistaging.

Check for tight seals or bearings.

2. Excessive friction due to damaged or improper / misaligned mounting.

Repair or replace as needed.

3. Cylinder sized too close to load requirements.

Reduce load or install larger cylinder.

4. Large difference between static and kinetic friction.

Install speed control valves to provide back pressure to control stroke.

Oil Spilling Out of Tank:

1. Oil is foaming.

(Refer to Foaming of Oil section)

2. Oil reservoir filled while cylinders were extended.

Fill while cylinders in the retract or closed position.

Foreign Matter Sources in the Circuit:

1. Pipe scale not properly removed.

Lines need cleaned and flushed before installation.

2. Sealing compound (pipe dope, teflon tape) allowed to get inside fittings.

Use care when applying sealants.

3. Improperly screened fill pipes and air breathers.

Repair or replace as required.

Troubleshooting Hints

4. Burrs inside piping components.

Deburr before installation.

5. Tag ends of packing coming loose.

Check if packing is system compatible.
Replace packing.

6. Seal extrusions from pressure higher than compatible with the seal or gasket.

Replace seal or gasket with compatible item.

7. Human element.

Not protecting components while being repaired.
Repaired components not properly protected while stored. (Rust and other contaminants.)
Lines left open and unprotected.

8. Wipers or boots damage or not provided.

Check cylinders or rams.
Add or replace where necessary.

Preventing repeat failures:

When a hydraulic system (pump or cylinder or other major component) has a failure, implementing this 13-step checklist can help prevent repeat failures.

1. Determine cause of failure.
2. Eliminate cause of failure.
3. Retract all cylinders and drain tank.
4. Flush tank. Using diesel fuel under pressure, flush tank thoroughly and wipe with clean cloths.
5. Install new filter elements.
 - A. Check to make sure filter is 10 microns or better.
 - B. If machine does not have filtration, install a 10 micron filter on the return line.
6. Install new component.
7. Fill the tank with new oil.
 - A. Be sure recommended oil is used.
 - B. NOTE; You're filling the system, not just the oil supply tank. Pump failure due to lack of oil can result if filling is not done correctly.
Keep a close check on the oil level as you complete the following steps.
8. Disconnect all lines to cylinders and/or motors at the cylinder or motor. Be sure all implements are securely blocked and all accumulators are bled before disconnecting lines. NOTE; It may be necessary to remove, inspect, and flush the fittings that are connected to the pump, valves, and/or cylinders to remove any foreign objects that may have become lodged or stuck inside them.
9. Activate each circuit by moving control valve handle so lines are flushed with new oil. This flushes the lines and valves from pump to all cylinders and motors. Be sure to check oil level, and add new oil if necessary.

10. Connect lines to blind end of cylinders and all fluid motors. Leave rod end disconnected and with engine at one-fourth throttle, activate circuits slowly until cylinder bottoms out. New oil will be put in the blind end of the cylinder and old dirty oil flushed out the rod end. Do this for all cylinders on the machine.

11. Connect lines to rod end of cylinders. Again, check oil level and add new oil as required.

12. Operate all cylinders and motors alternately for 30 minutes at normal operating speed.

13. Change filter element, check oil level and add oil as needed.

The above procedure, if followed, will allow you to install a new pump or cylinder with confidence, knowing that you'll get satisfactory life. Cutting short these steps can cause premature hydraulic component failure; a pump, nor a cylinder will run long on a contaminated system. In nearly all cases, a replacement component will fail in a shorter time than the original preceding it unless the system is thoroughly cleaned.

In addition, to ensure good service from your equipment, the hydraulic system must be properly maintained, including frequent oil level checks, daily inspection for leaks, filter element and oil changes at recommended intervals (using correct filters and recommended grade of oil), and finally, practicing good operating techniques.

Dump Hoist Type Identification Chart

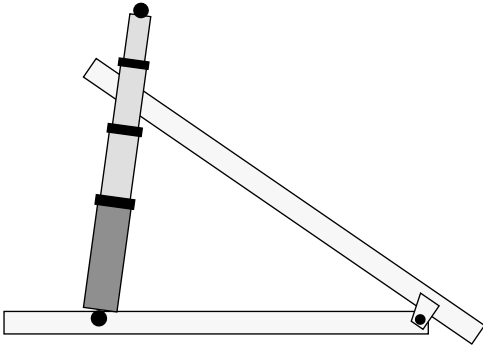

FRONT MOUNT TELESCOPIC
HEAD LIFT OR BOTTOM LIFT

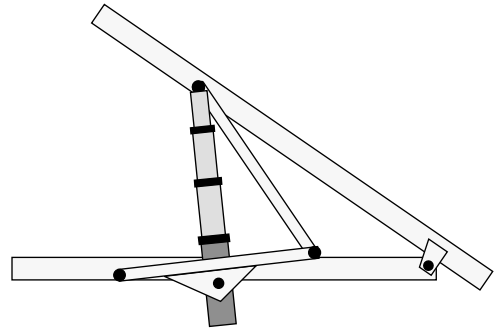

TELESCOPIC SCISSOR
HINGE FORWARD OR REARWARD

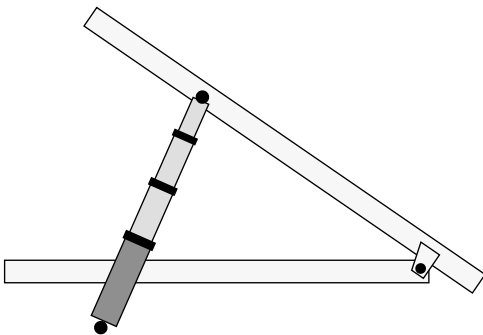

UNDERBODY TELESCOPIC
SLANT FORWARD OR SLANT REARWARD

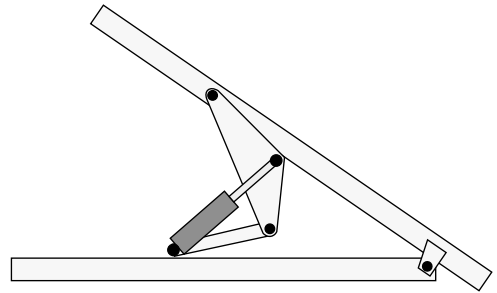

SINGLE STAGE SCISSOR

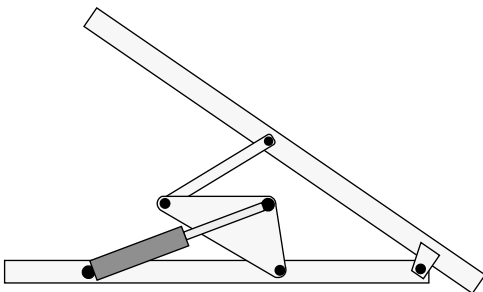

UNDER BODY ARM HOIST

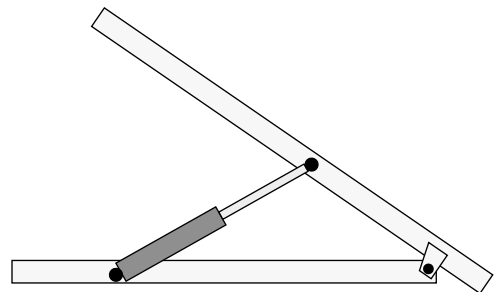

UNDER BODY DIRECT LIFT

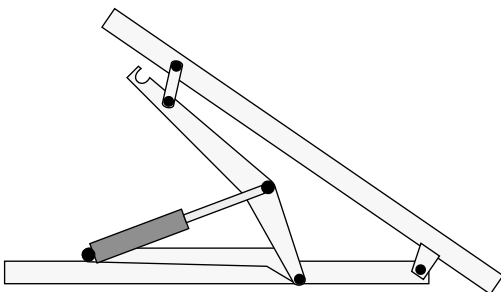

UNDER BODY ARM - SCISSOR

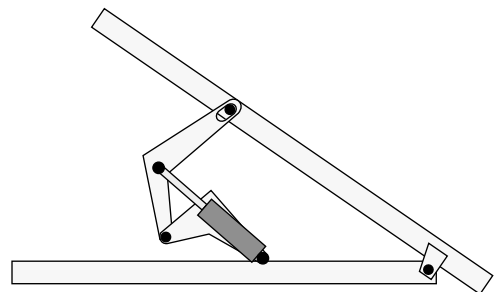

LOST MOTION SCISSOR

Dump Trailer Type Identification Chart

FRAME TYPE

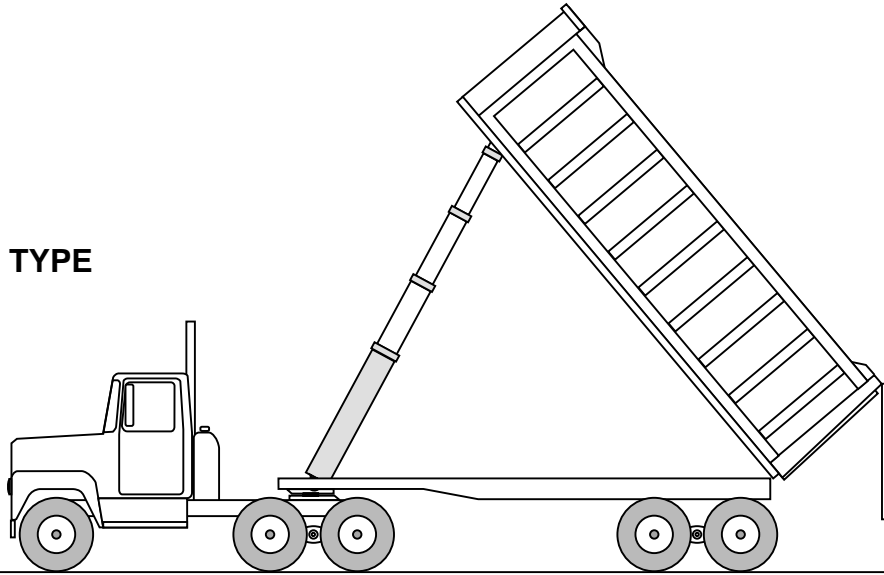

FRAMELESS

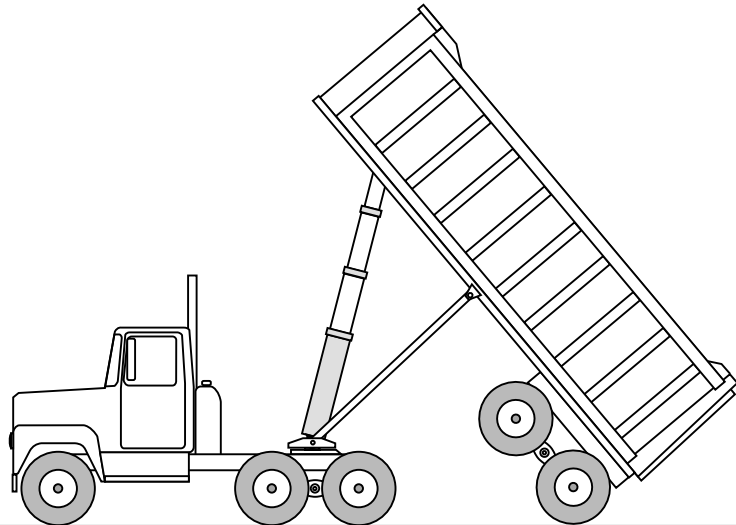

FRAMELESS HYBRID

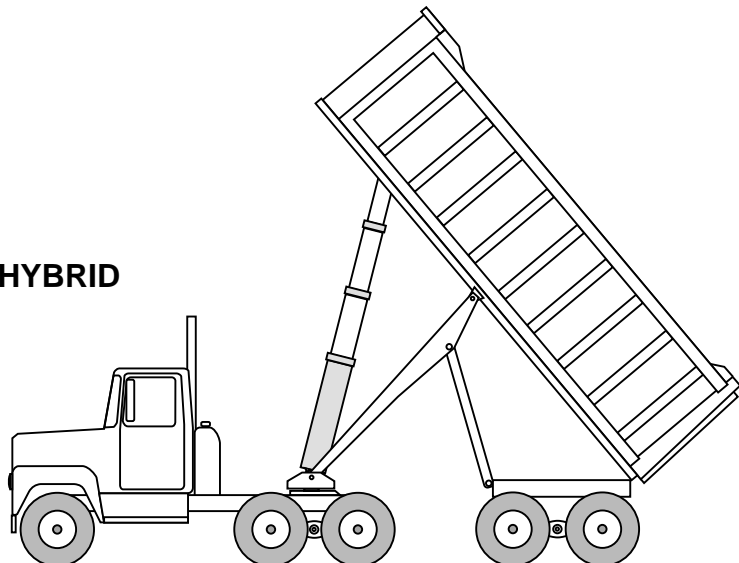

Front Loader Refuse Bodies

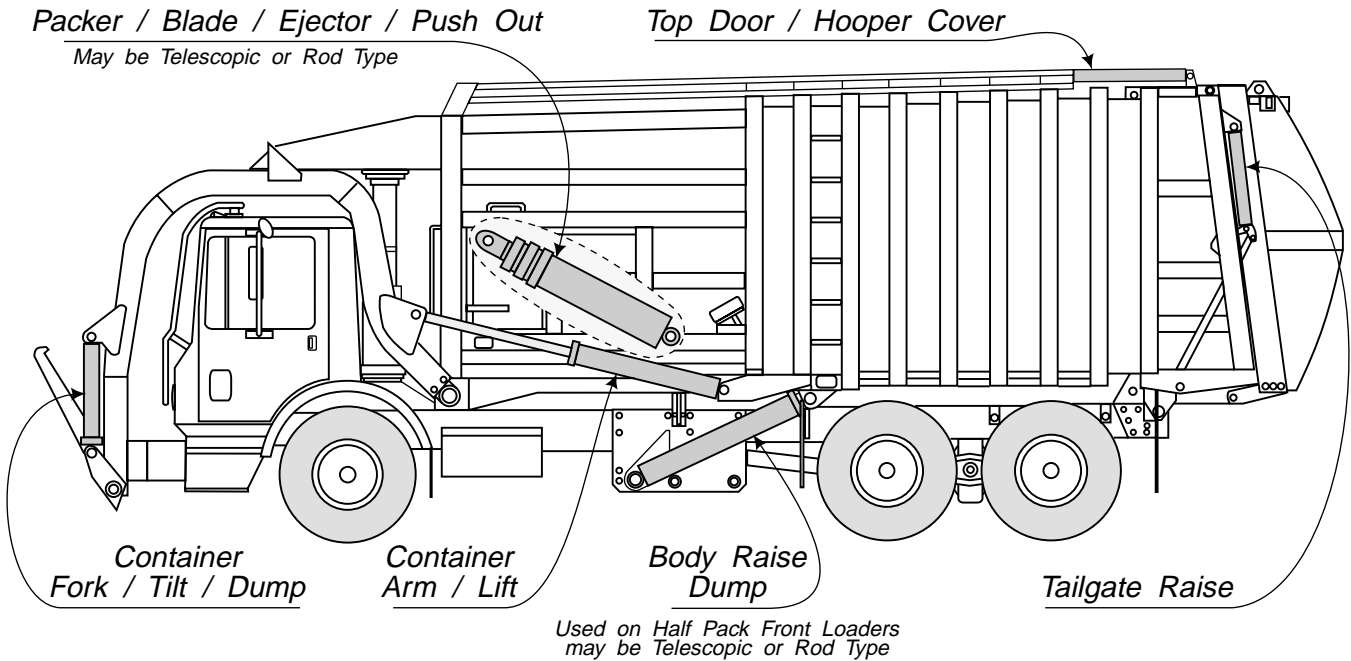

Rear Loader Refuse Bodies

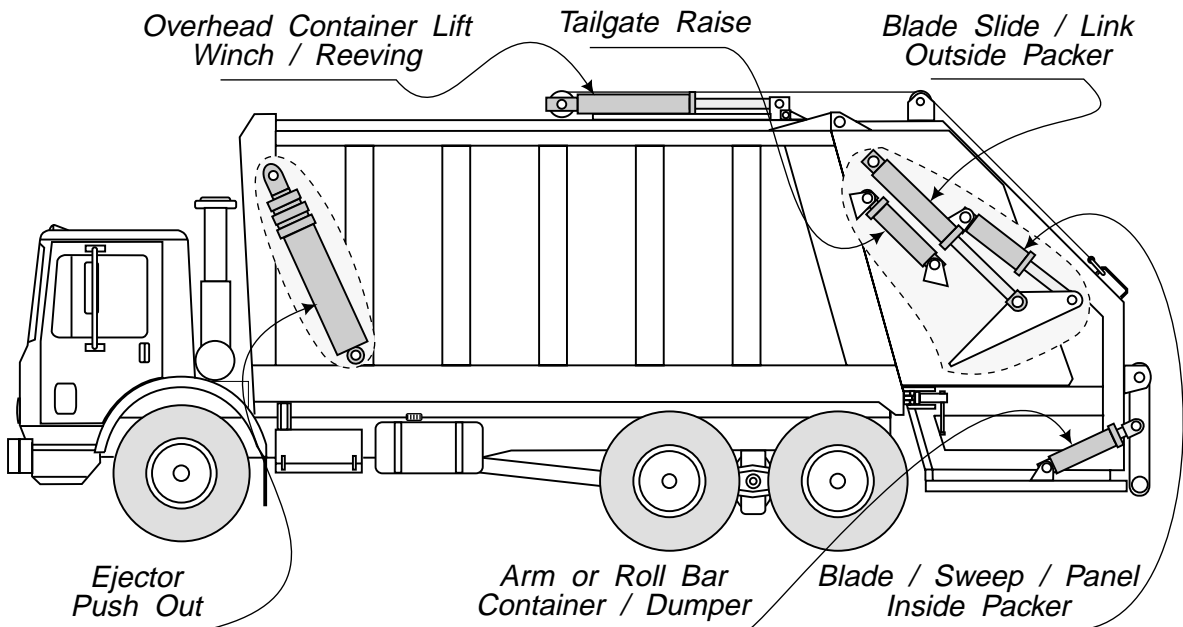

Crossover and Application Data is for Reference Only.
No Other Conditions are Expressed or Implied.

Side Loader Refuse Bodies

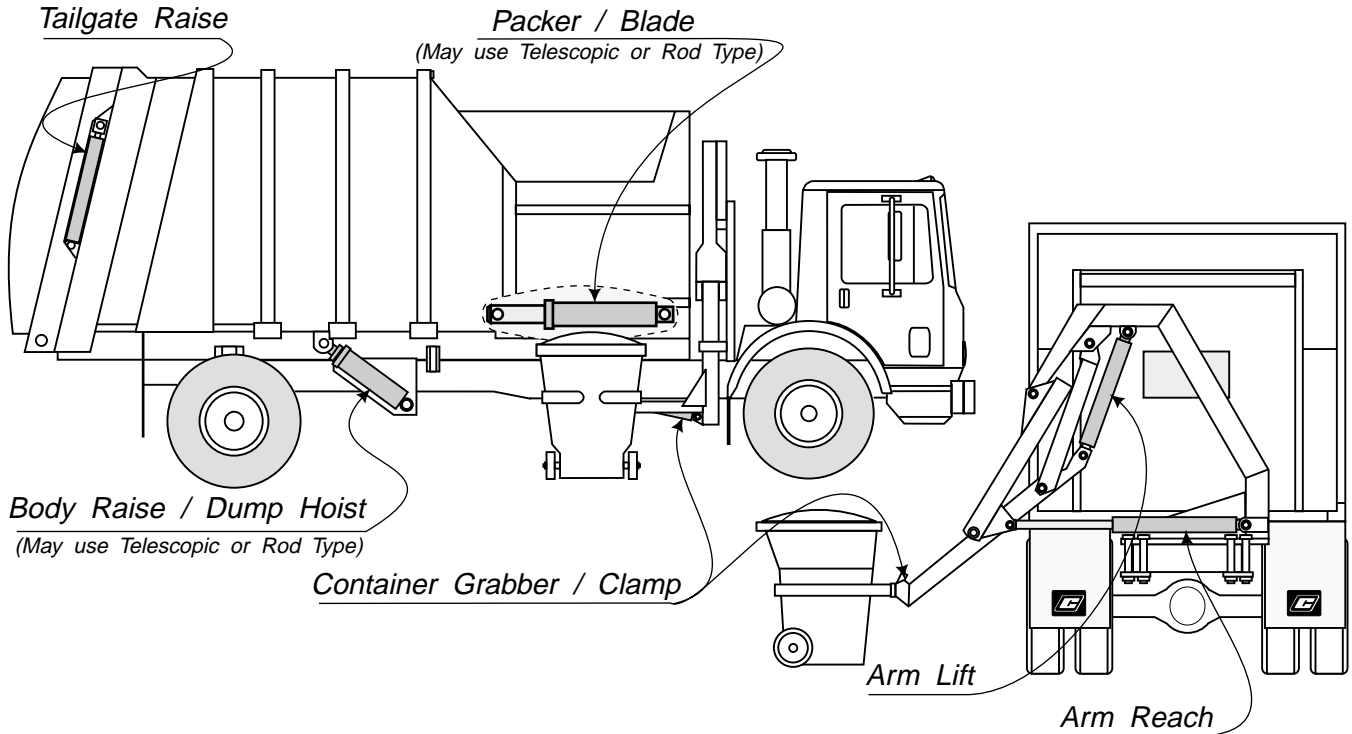

Roll-Off & Tilt Frame Hoists

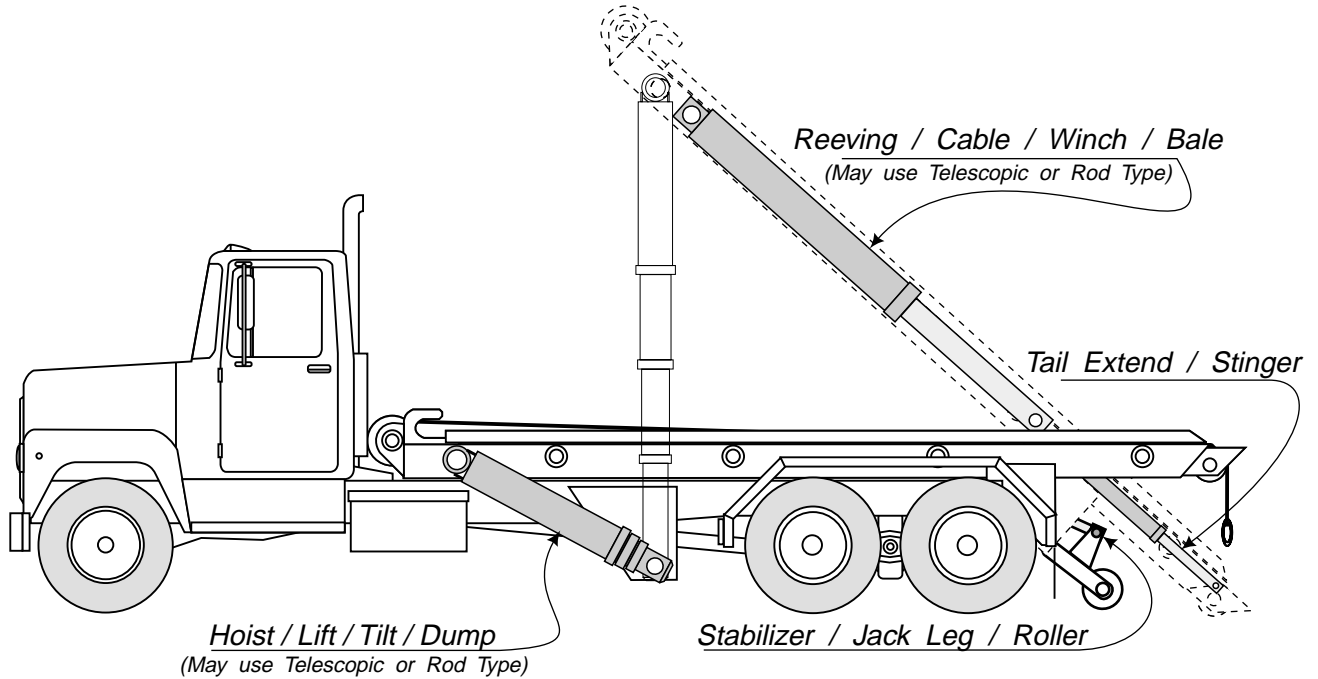

Crossover and Application Data is for Reference Only.
No Other Conditions are Expressed or Implied.

ANTHONY

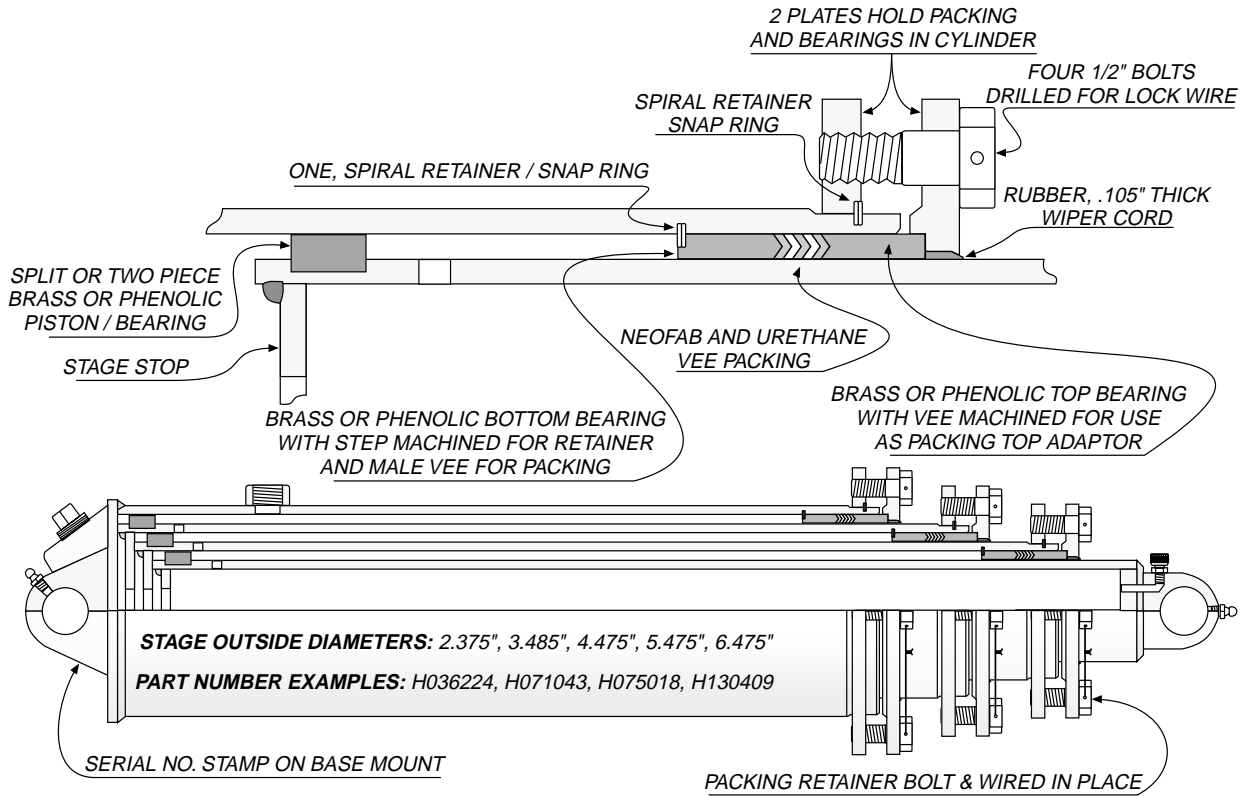

COMMERCIAL

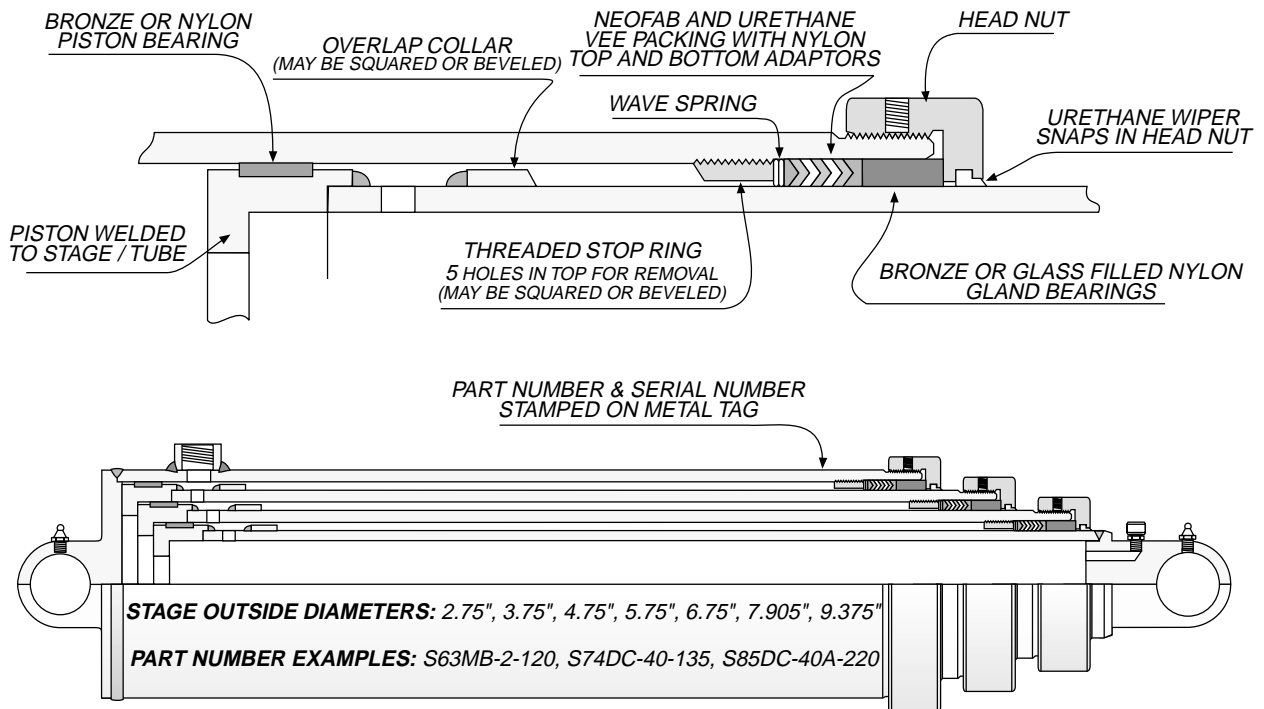

CUSTOM HOIST

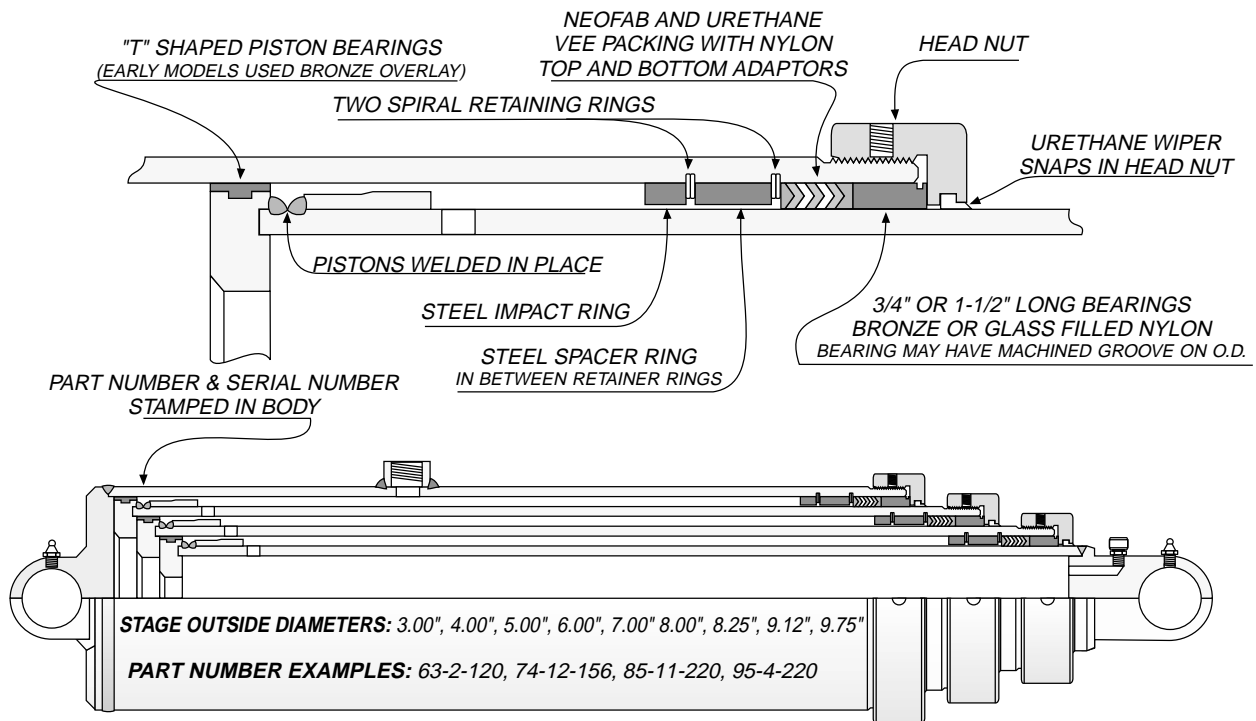

FONTAINE

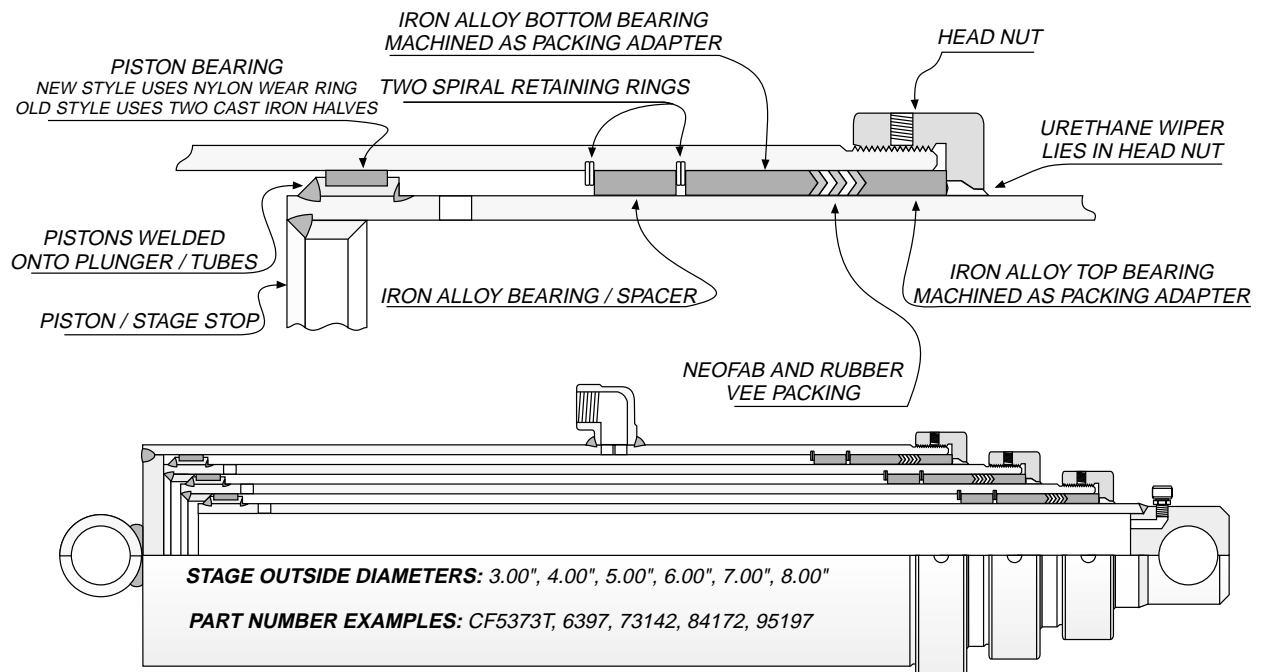

PEABODY GALION

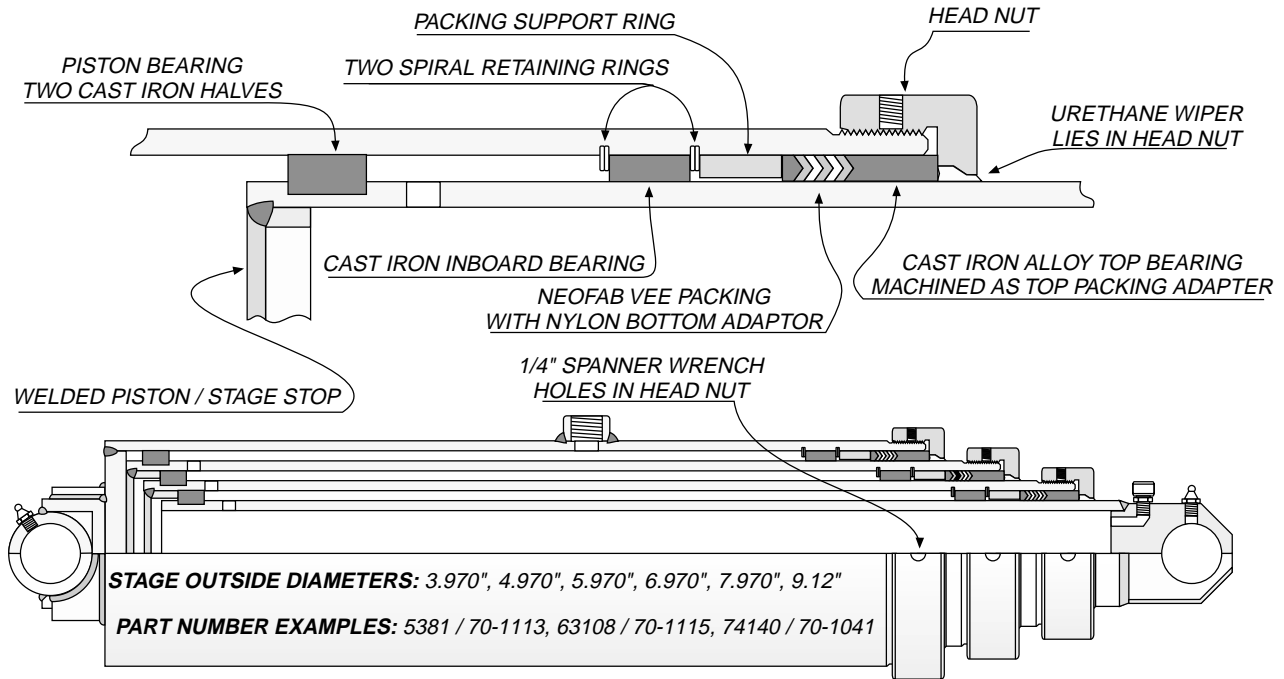

GLENCO / FARMHAND

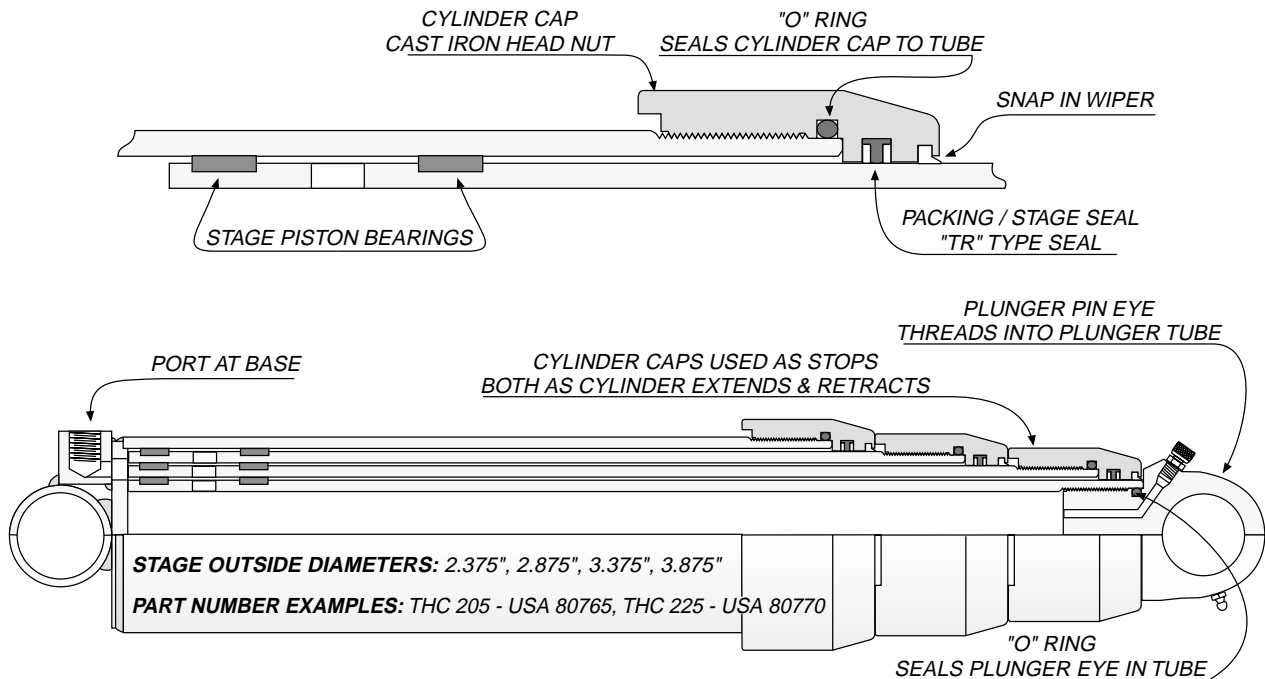

HEIL "OLD STYLE" HPT SERIES

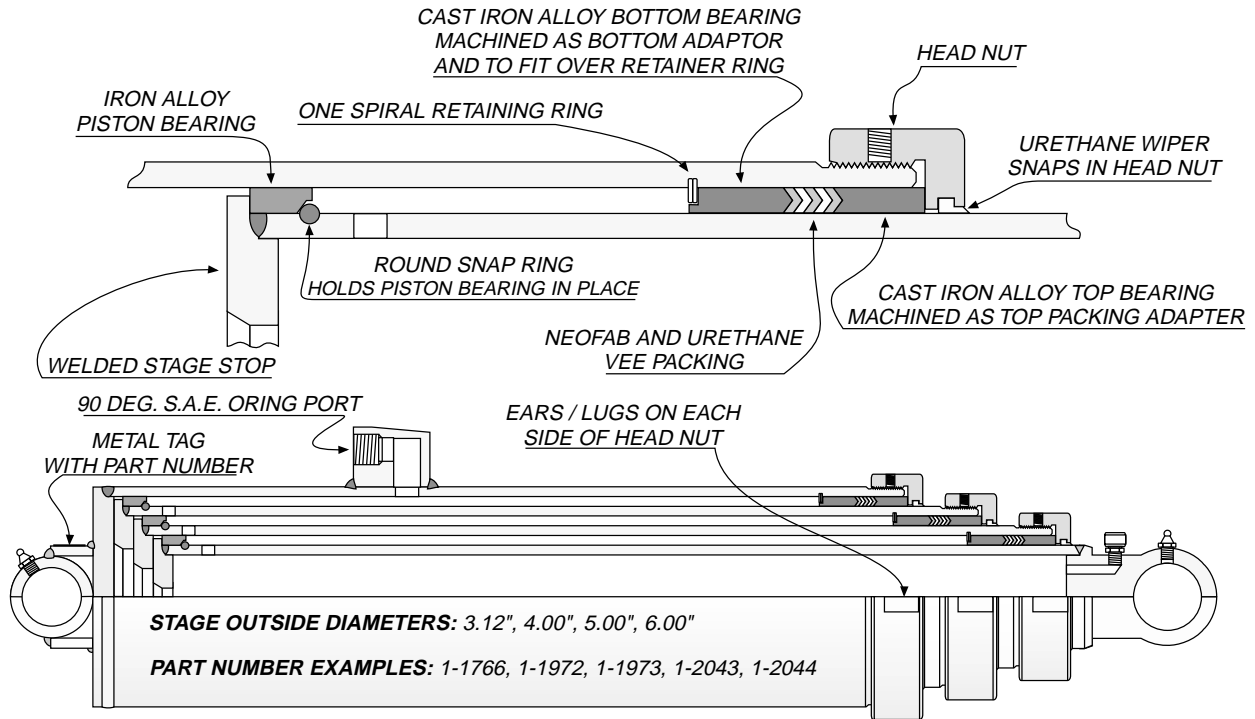

HEIL "NEW STYLE" HPT SERIES

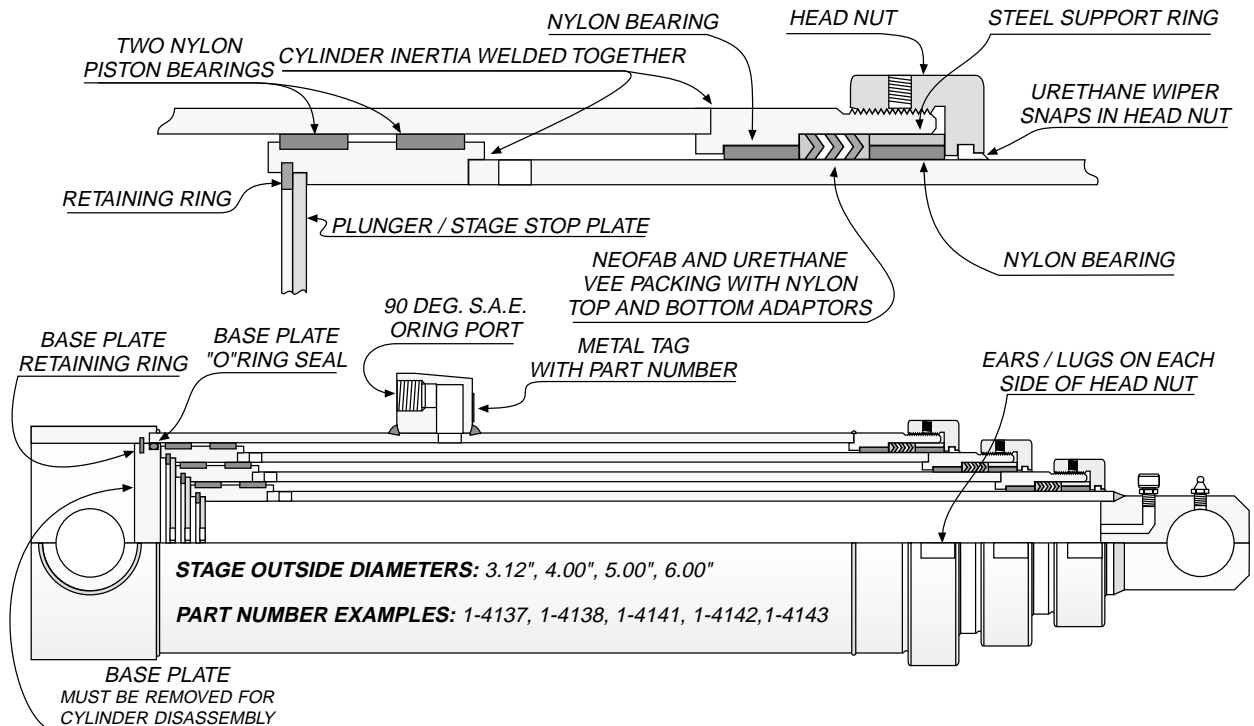

HYCO 900 - 2000 SERIES

(MFG. PRIOR TO 6/74)

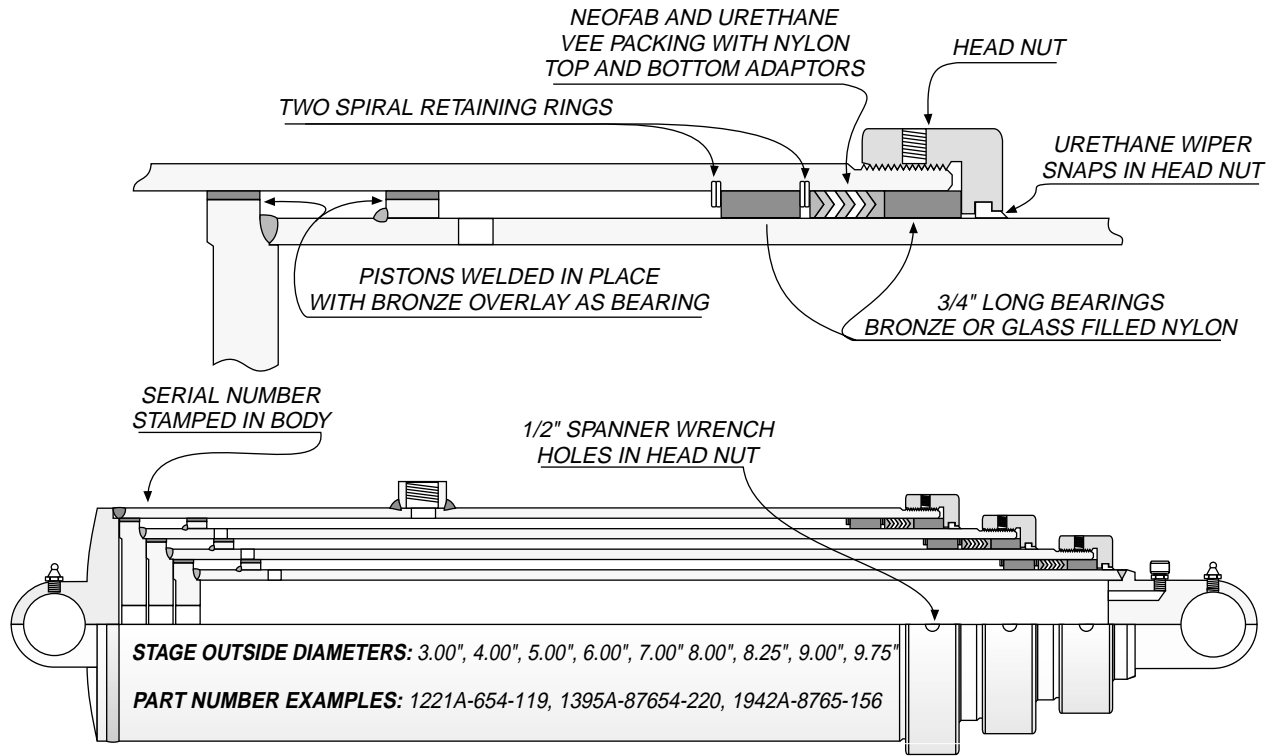

HYCO 10,000 SERIES

(MFG. FROM 7/74 TO 8/76)

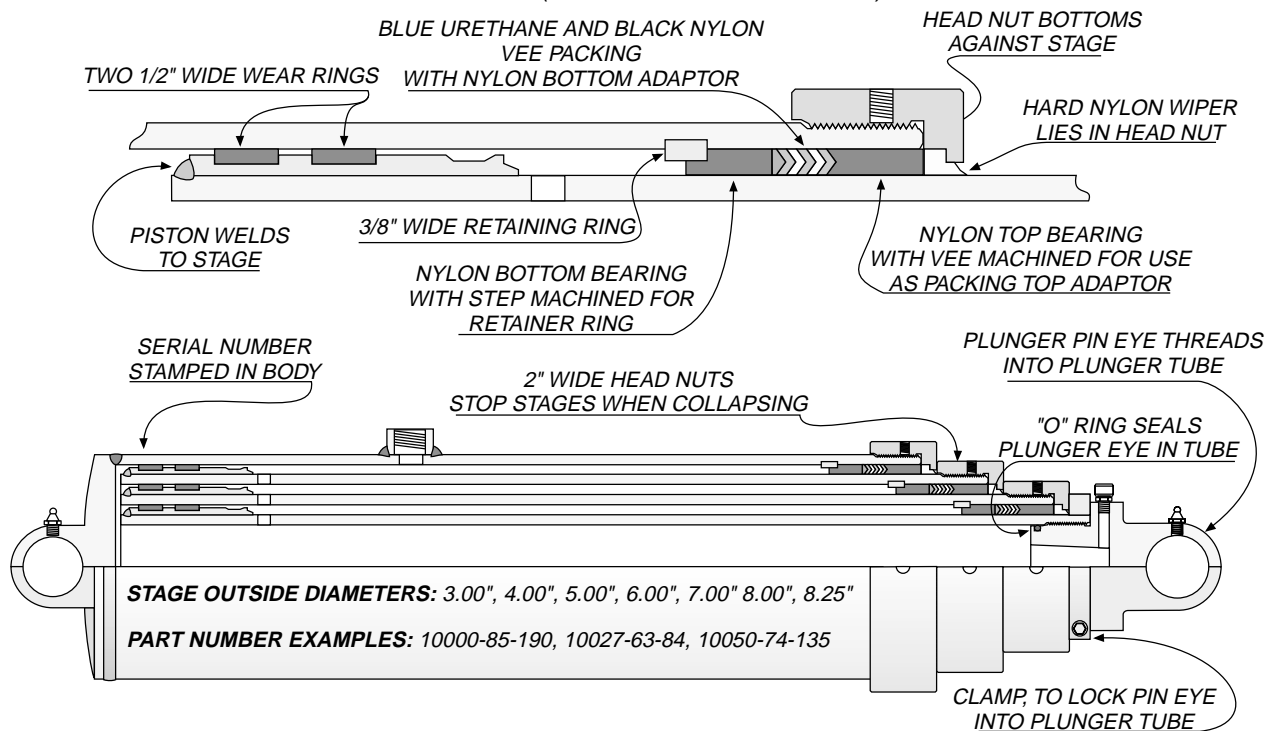

HYCO 30,000 SERIES

(OLD STYLE MFG. FROM 8/76 TO 7/81)
 (NEW STYLE MFG. FROM 8/81 TO PRESENT)

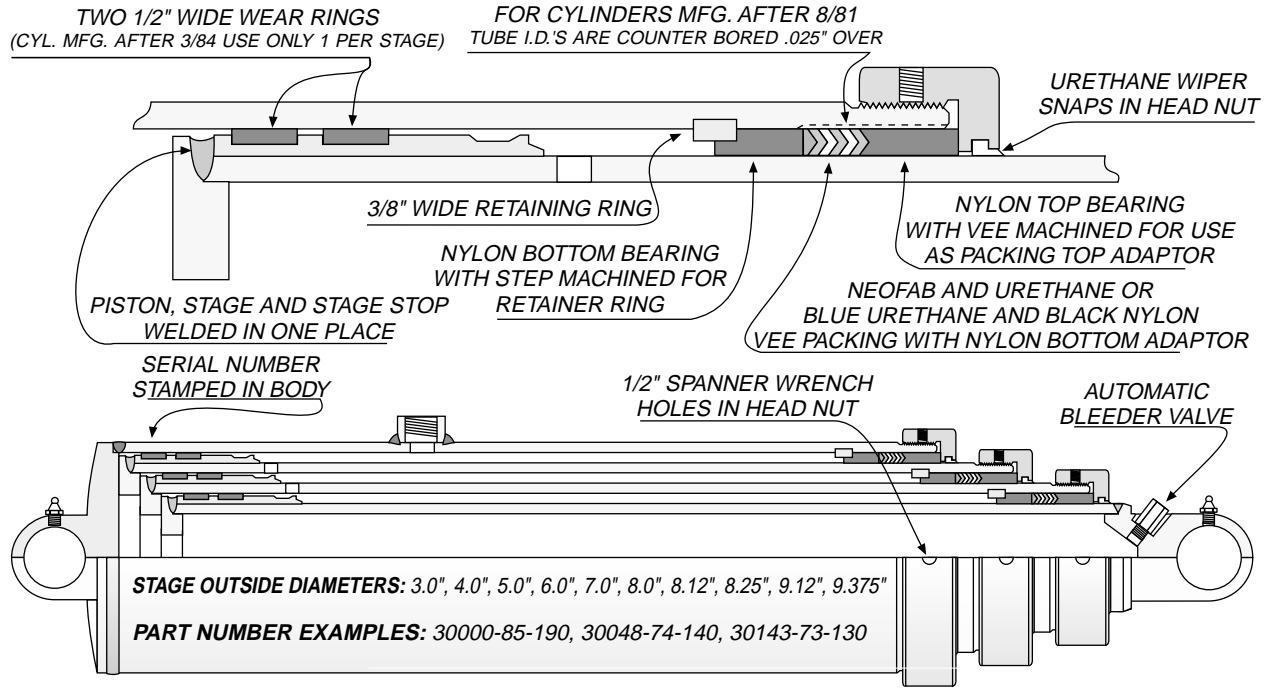

HYCO 70,000 SERIES

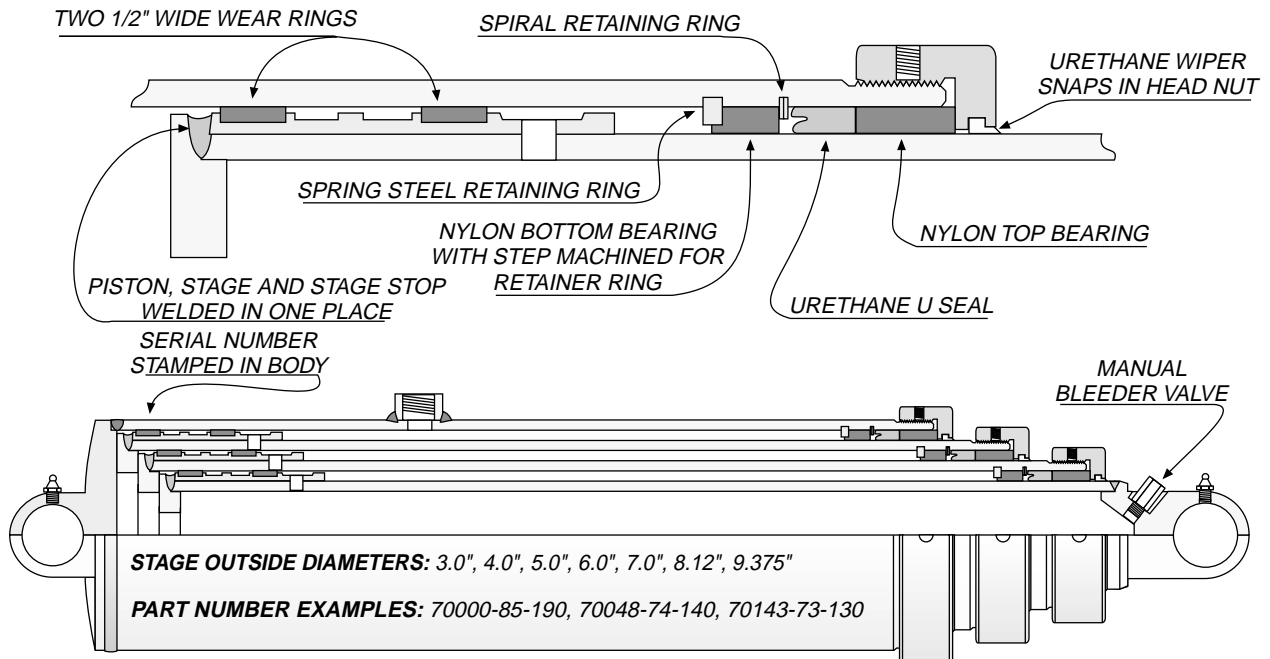

JOHNSON

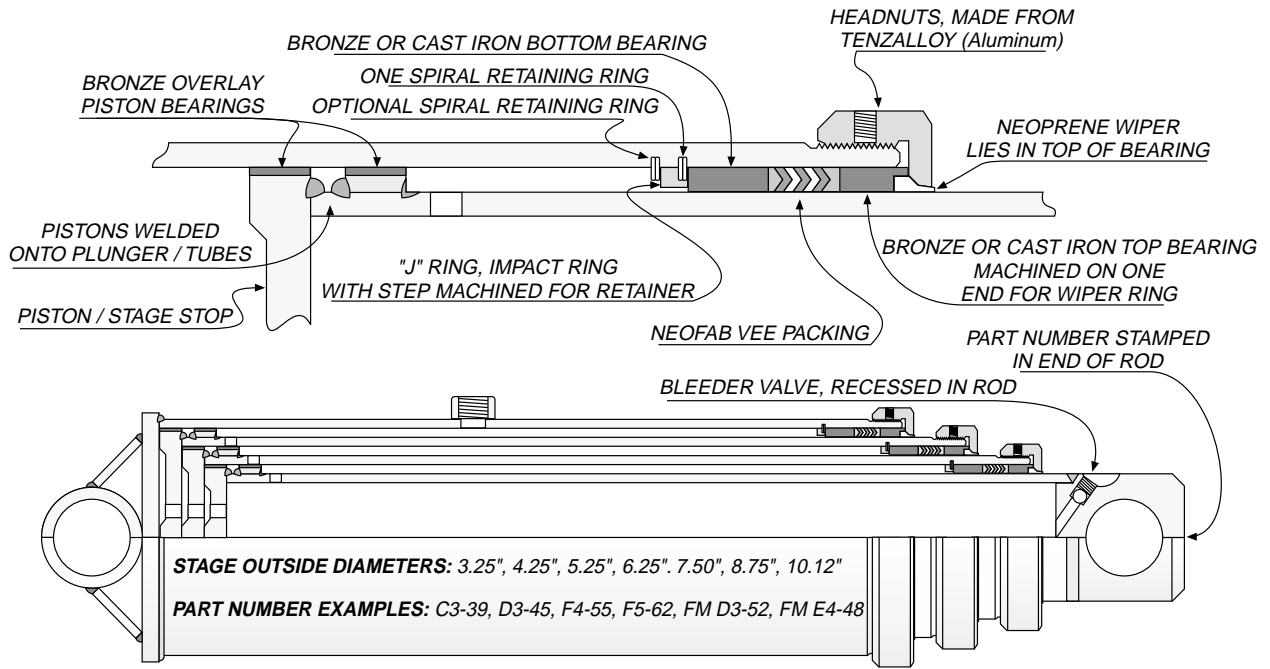

LESSARD / DRASSEL COVER TUBE DESIGN

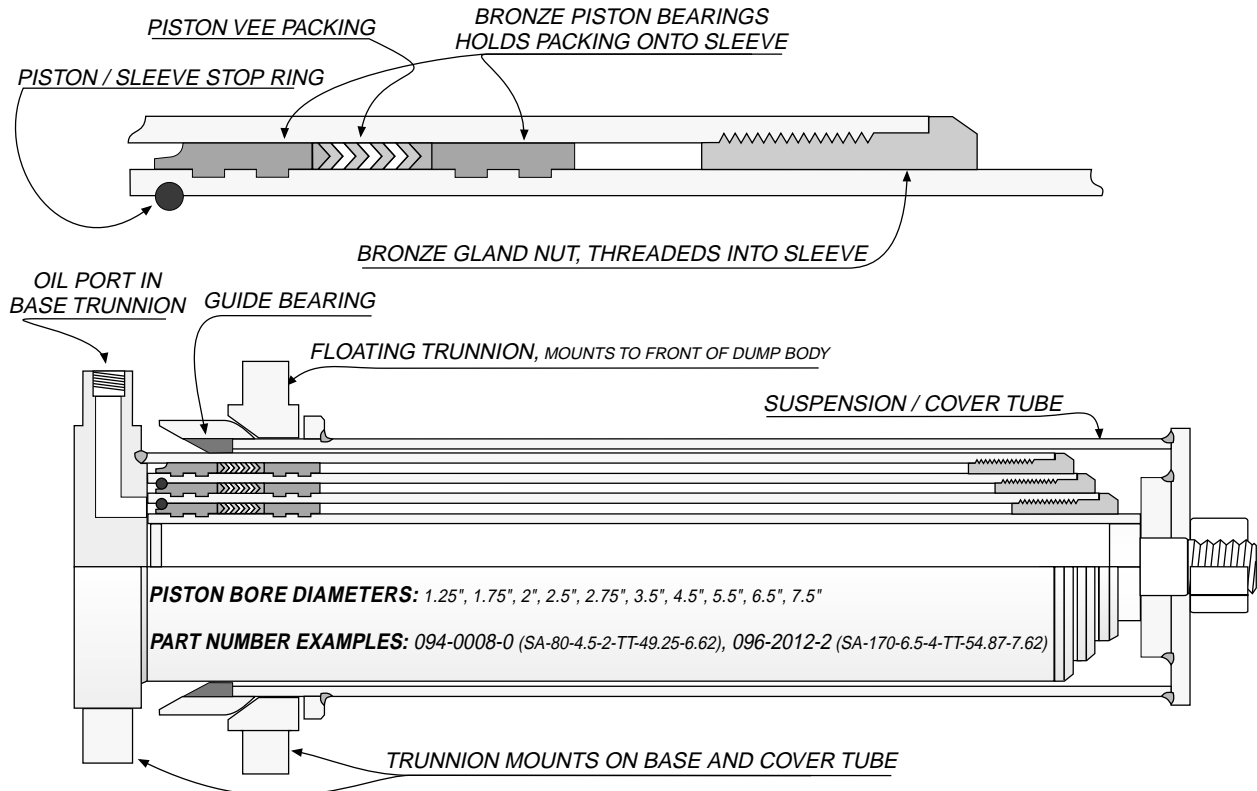

MAILHOT / "C" MODEL

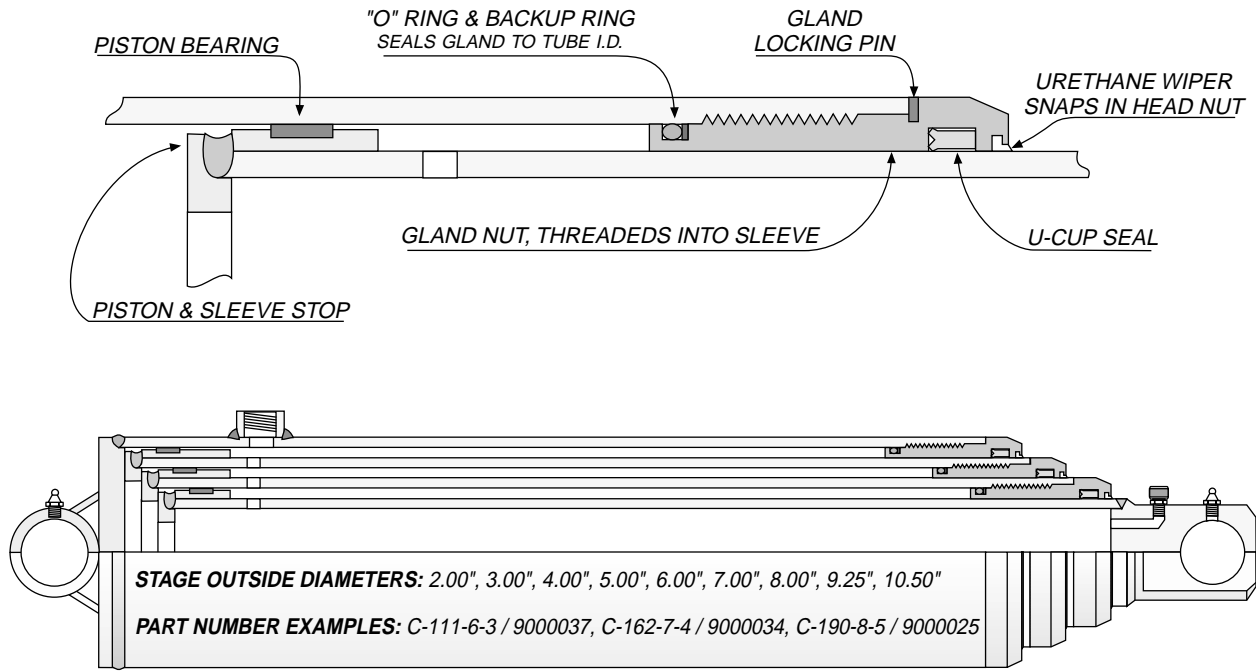

MAILHOT / "M" MODEL COVER TUBE DESIGN

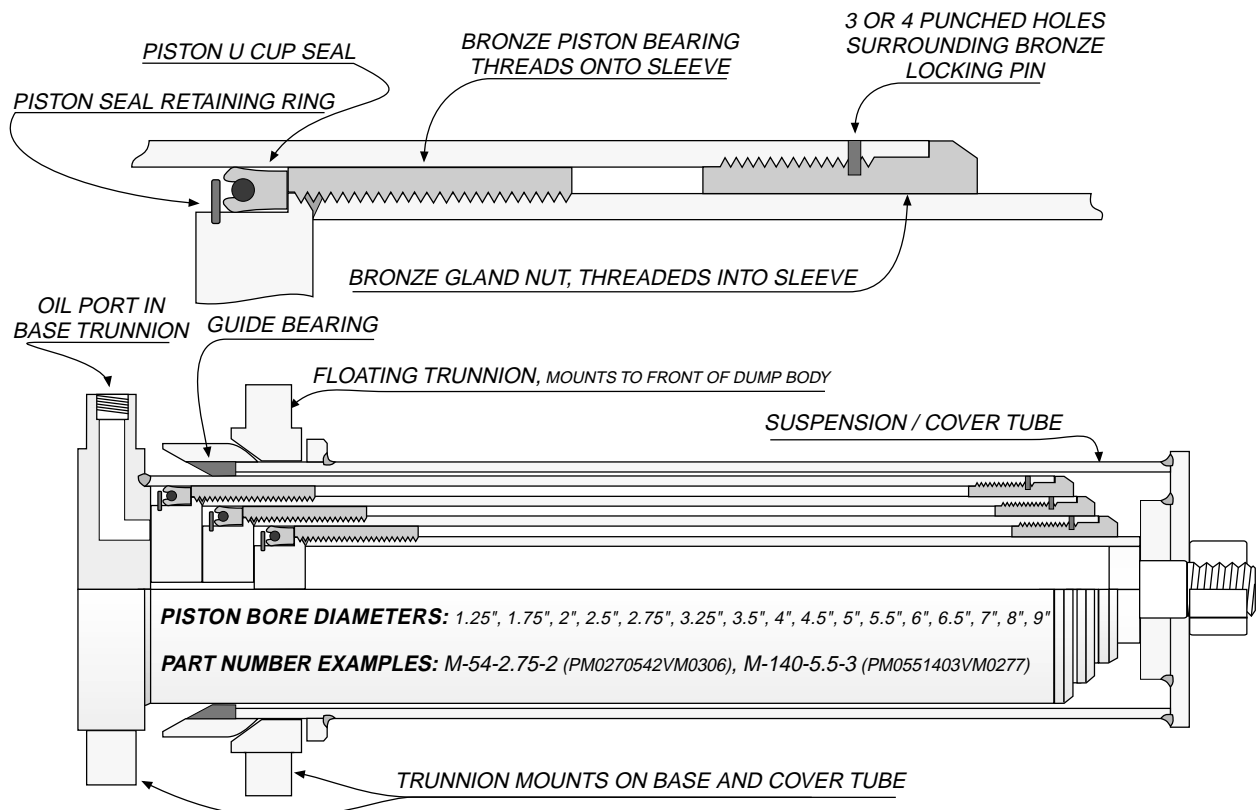

MARION MFG.

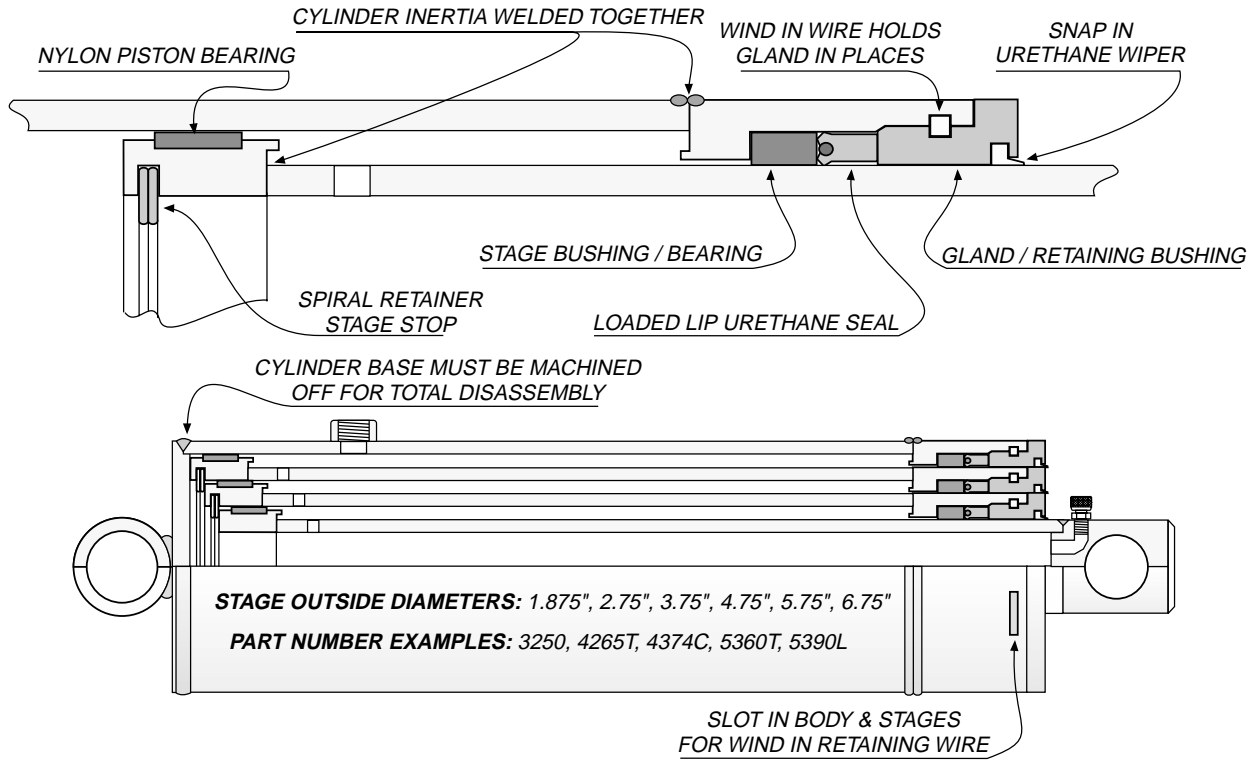

NORDIC / NORD-SEN METAL INDUSTRIES

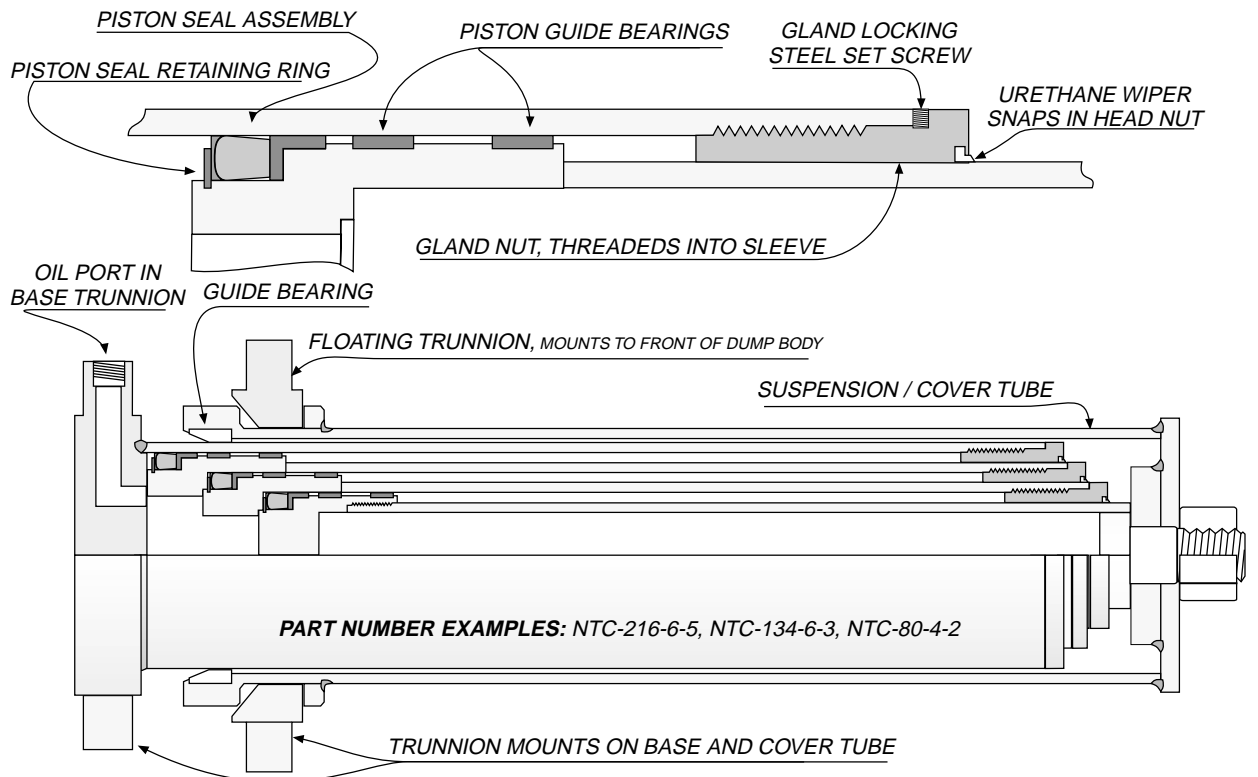

PERFECTION

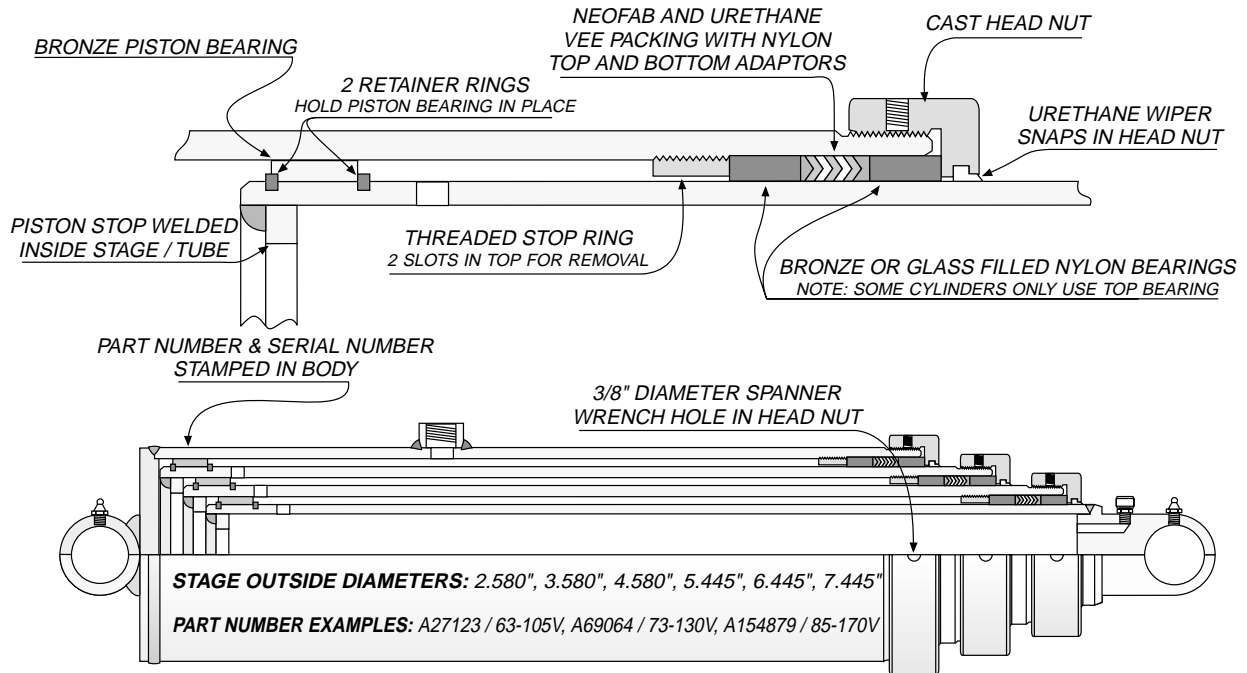

PERFECTION FARM HOISTS

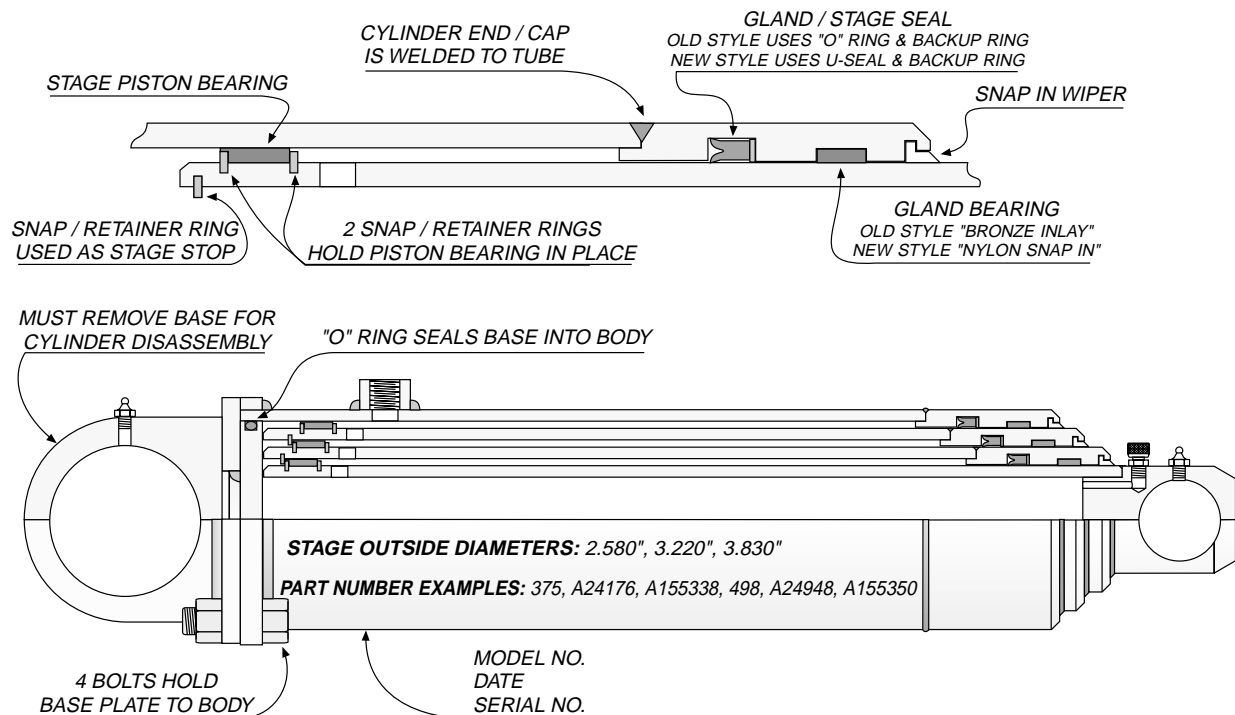

PRINCE

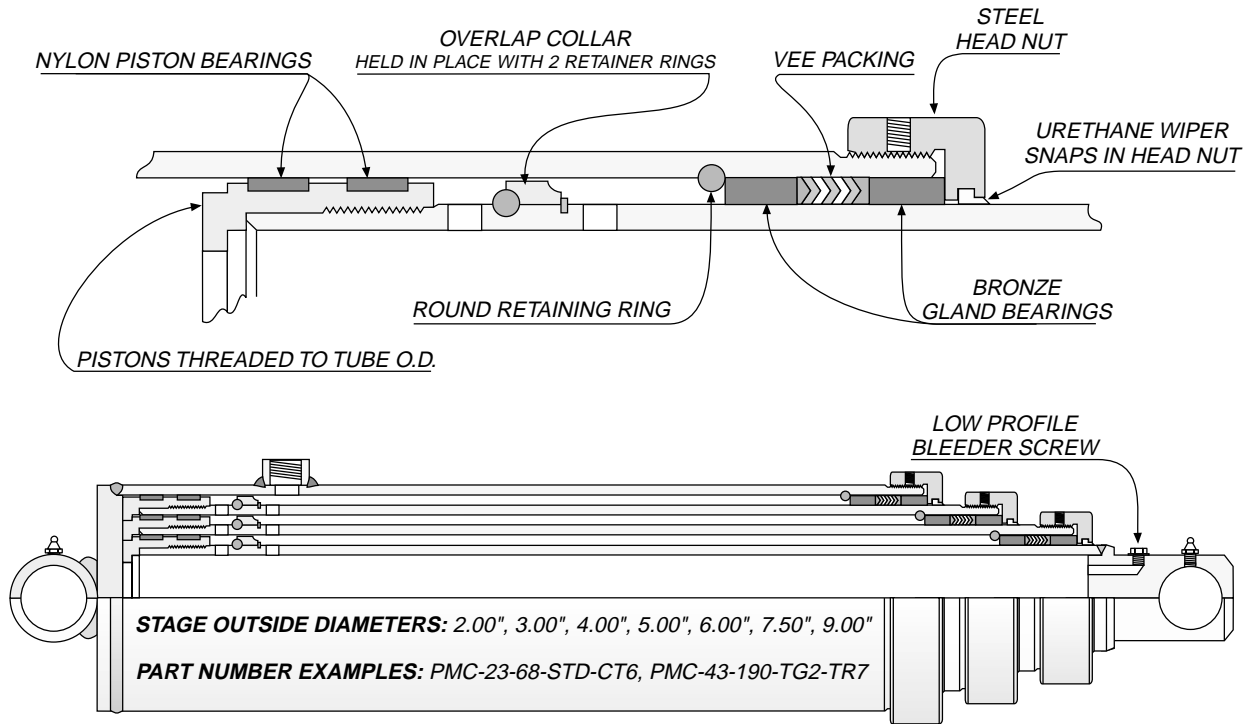

WARD CO

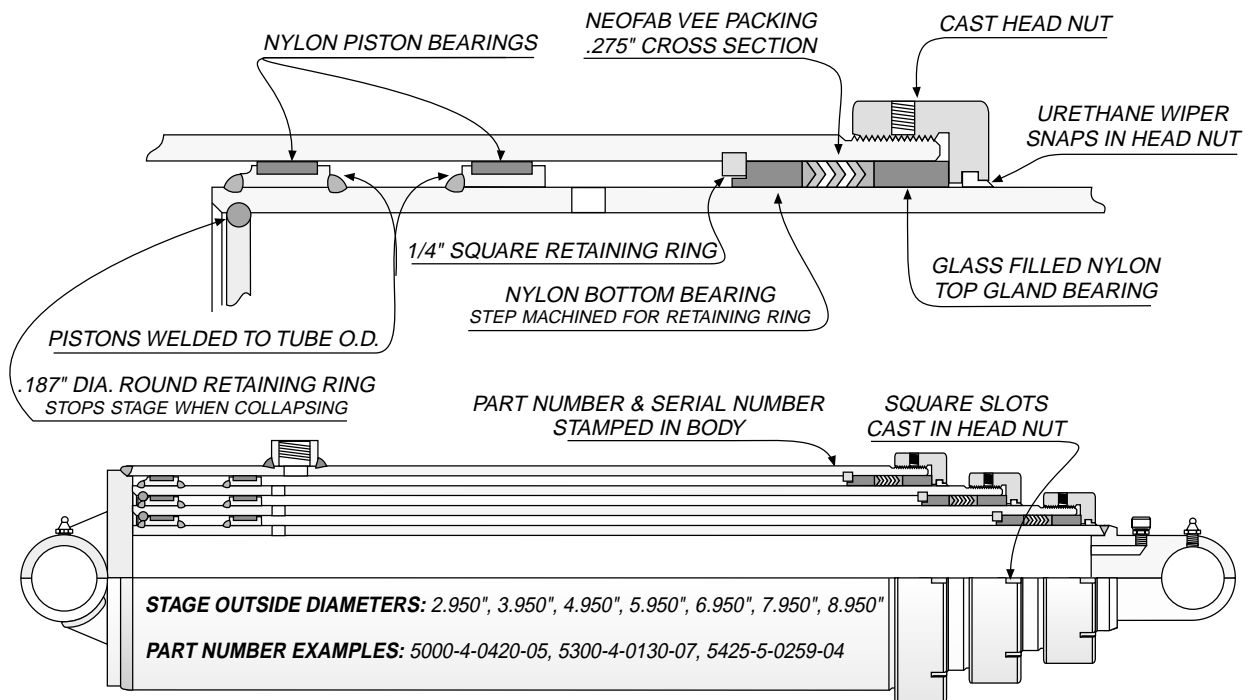

Quick Reference Guide

ANTHONY MIDWEST BODY

H070105	S63DC-44-111 CM26
H071043	S73DC-40-110 CM23
H0710432	S73DC-40-110 CM26
H075018	S73DC-40-124 CM23
H0750182	S73DC-40-124 CM26
H130409	S63DC-47-140 CM26

BENTON HARBOR

P89645	D70LN-2-80
P89648	D60DB-7-72

BIBEAU

CYLM100353	S43MM-1G-100
CYLM100453	S53MM-1G-100
CYLM110453	S53MM-1G-110
CYLM110553	S63MM-1G-110
CYLM120453	S53MM-1G-120
CYLM120553	S63MM-1G-120
CYLM130553	S63MM-1G-130
CYLM130653	S73MM-1G-130
CYLM140653	S73MM-1G-140
CYLM150553	S63MM-1G-140
CYLM150654	S74MM-2G-150
CYLM160654	S74MM-2G-160
CYLM170654	S74MM-2G-170
CYLM18274	S74MM-4G-182
CYLM19574	S74MM-4G-195
CYLM90353	S43MM-1G-90
CYLM90452SA	S52MM-1G-90

COMMERCIAL HYDRAULICS

D60DB-4-72	D60DB-7-72
D60DD-5-69	D60DD-4-69
D60DD-6-69	D60DD-4-69
D62DB-5-15	D62DB-9-15
D62DB-7-72	D60DB-7-72
D62LB-2-81	D62LB-5-80
D70LN-1-80	D70LN-2-80
D72DB-3-15	D72DB-7-15
D72DB-3-25	D72DB-7-25
D72DB-4-15	D72DB-7-15
D72DB-4-25	D72DB-7-25
D72DB-4-25-1	D72DB-7-25-1
D72LB-6-81	D72LB-9-80
D72LP-1-80	D70LN-2-80
D84DB-3-25	D84DB-7-25
D84DB-4-25	D84DB-7-25
D84DB-4-25-1	D84DB-7-25-1
D84DB-5-25	D84DB-7-25
D84DB-5-25-1	D84DB-7-25-1
S42MB-1-90	S42MB-3-90
S53DB-1-103	S53DB-8-103
S53DC-3-72	S53DC-14-72
S53DC-3-84	S53DC-14-84
S53DC-5-107	S53DC-11-107
S53DC-5-126	S53DC-11-126
S53DC-6-99	S53DC-15-99
S53DC-6-105	S53DC-15-105
S53DC-6-120	S53DC-15-120
S53DC-6-123	S53DC-15-123
S53DC-7-84	S53DC-14-84
S53DC-8-104	S53DC-11-104

COMMERCIAL HYDRAULICS

S53DC-8-120	S53DC-11-120
S53DC-8-130	S53DC-11-130
S53DC-10-72	S53DC-14-72
S53DC-10-84	S53DC-14-84
S53DC-12-104	S53DC-11-104
S53DC-12-120	S53DC-11-120
S53DC-12-130	S53DC-11-130
S53DC-13-104	S53DC-11-104
S53DC-13-126	S53DC-11-126
S53DC-19-90	S53DB-12-90
S53MB-1-120	S53MB-3-120
S62CC-15-69	S62CC-30-69
S63CC-22-80	S63DC-47-77
S63CC-22-111	S63DC-44-111
S63CC-22-123	S63DC-44-123
S63DC-3-111	S63DC-44-111
S63DC-22-111	S63DC-44-111
S63DC-22-123	S63DC-44-123
S63DC-22-80	S63DC-47-77
S63DC-23-108	S63DC-44-111
S63DC-23-128	S63DC-47-130
S63DC-26-111	S63DC-44-111
S63DC-27-111	S63DC-44-111 CM9
S63DC-30-111	S63DC-44-111
S63DC-30-123	S63DC-44-123
S63DC-31-107	S63DC-47-107 CM37
S63DC-31-126	S63DC-44-123 CM37
S63DC-32-120	S63DC-45-120
S63DC-32-126	S63DC-45-126
S63DC-32-138	S63DC-45-138
S63DC-32-162	S63DC-45-162
S63DC-33-105	S63DC-47-107
S63DC-36-120	S63DC-45-120
S63DC-37-82	S63DC-47-82
S63DC-41-120	S63DC-47-120 CM9
S63DC-41-130	S63DC-47-130 CM9
S63DC-41-140	S63DC-47-140 CM9
S63DC-43-123	S63DC-44-123
S63DC-46-107	S63DC-47-107 CM37
S63DC-46-126	S63DC-44-123 CM37
S63DC-48-120	S63DC-47-120 CM9
S63DC-48-130	S63DC-47-130 CM9
S63DC-48-140	S63DC-47-140 CM9
S63DC-52-77	S63DC-47-77
S63MB-1-120	S63MB-9-120
S63MB-1-140	S63MB-8-140
S63MB-2-120	S63MB-9-120
S63MB-5-108	S63MB-11-108
S63MB-8-120	S63MB-9-120
S64DB-1-135	S64DB-6-135
S64DB-1-156	S64DB-6-156
S64DB-2-135	S64DB-6-135
S64DB-2-156	S64DB-6-156
S64DB-3-135	S64DB-6-135
S64DB-3-156	S64DB-6-156
S64DB-4-135	S64DB-6-135
S64DB-4-156	S64DB-6-156
S64DB-5-135	S64DB-6-135
S64DB-5-156	S64DB-6-156
S64DC-1-157	S64DC-7-157
S64DC-2-157	S64DC-7-157
S64DC-4-156	S64DC-9-156
S64DC-5-156	S64DC-9-156

COMMERCIAL HYDRAULICS

S64MB-1-140	S64MB-4-140
S73CC-17-110	S73DC-40-110
S73CC-22-110	S73DC-40-110
S73CC-22-124	S73DC-40-124
S73DB-1-142	S73DC-40-140 CM23
S73DC-22-110	S73DC-40-110
S73DC-22-124	S73DC-40-124
S73DC-30-110	S73DC-40-110
S73DC-30-124	S73DC-40-124
S73DC-30-129	S73DC-41-129
S73DC-30-140	S73DC-40-140
S73DC-32-129	S73DC-41-129
S73DC-32-140	S73DC-40-140
S73DC-33-124	S73DC-40-124
S73DC-35-120	S73DC-40-120
S73DC-40-129	S73DC-41-129
S73DC-41-140	S73DC-40-140
S73DC-64-129	S73DC-41-129
S73DC-65G-129	S73DC-41-129
S74CC-22-120	S74DC-40A-120
S74CC-22-134	S74DC-40-135
S74CC-22-161	S74DC-40-161
S74DC-3-134	S74DC-40-135
S74DC-5-135	S74DC-41-135
S74DC-6-135	S74DC-40-135
S74DC-22-120	S74DC-40A-120
S74DC-22-134	S74DC-40-135
S74DC-22-161	S74DC-40-161
S74DC-30-120	S74DC-40A-120
S74DC-30-135	S74DC-40-135
S74DC-30-138	S74DC-40-135
S74DC-30-140	S74DC-40A-140
S74DC-30-156	S74DC-40-156
S74DC-30-161	S74DC-40-161
S74DC-31-161	S74DC-40-161
S74DC-33-161	S74DC-40-161
S74DC-40-120	S74DC-40A-120
S74DC-40-138	S74DC-40-135
S74DC-40-140	S74DC-40A-140
S74DC-42-135	S74DC-40-135
S74DC-42-156	S74DC-40-156
S74DC-42-161	S74DC-40-161
S74DC-64G-161	S74DC-40-161
S74MB-2-154	S74MB-3-154
S74MM-1-160	S74MM-2G-160
S74MM-2-160	S74MM-2G-160
S83CC-22-160	S83DC-40-160
S83DC-6-134	S83DC-26-134
S83DC-22-160	S83DC-40-160
S83DC-25-160	S83DC-40-160
S83DC-30-139	S83DC-40-139
S83DC-30-160	S83DC-40-160
S83DC-31-139	S83DC-40-139
S83DC-31-160	S83DC-40-160
S83DC-32-139	S83DC-40-139
S83DC-33-139	S83DC-40-139 CM19
S84CC-4-183	S84DC-40-188
S84CC-6-183	S84DC-40-180
S84CC-8-166	S84DC-40-161 CM38
S84CC-8-183	S84DC-40-180 CM38
S84CC-22-134	S84DC-40-140
S84CC-22-149	S84DC-40-148

Crossover and Application Data is for Reference Purpose Only. No Other Conditions are Expressed or Implied.

Note: In some applications, modifications may be required for proper cylinder installation.

Quick Reference Guide

COMMERCIAL HYDRAULICS

S84CC-22-155	S84DC-40-161
S84CC-22-172	S84DC-40-180
S84CC-22-183	S84DC-40-188
S84DC-4-134	S84DC-40-140
S84DC-4-149	S84DC-40-148
S84DC-4-183	S84DC-40-188
S84DC-7-183	S84DC-40-180
S84DC-8-134	S84DC-40-140
S84DC-8-149	S84DC-40-148
S84DC-22-134	S84DC-40-140
S84DC-22-149	S84DC-40-148
S84DC-22-155	S84DC-40-161
S84DC-22-161	S84DC-40-161
S84DC-22-172	S84DC-40-180
S84DC-22-183	S84DC-40-180
S84DC-25-134	S84DC-40-140
S84DC-25-149	S84DC-40-148
S84DC-25-161	S84DC-40-161
S84DC-25-183	S84DC-40-180
S84DC-30-134	S84DC-40-140
S84DC-30-149	S84DC-40-148
S84DC-30-161	S84DC-40-161
S84DC-30-183	S84DC-40-180
S84DC-40-134	S84DC-40-140
S84DC-40-149	S84DC-40-148
S84DC-40-183	S84DC-40-180
S84DC-45-134	S84DC-40-140
S84DC-45-149	S84DC-40-148
S84DC-45-183	S84DC-40-180
S84DC-46-134	S84DC-40-140
S84DC-46-149	S84DC-40-148
S84DC-46-183	S84DC-40-180
S84DC-47-148	S84DC-40-148
S85CC-7-197	S85DC-40-197
S85CC-7-220	S85DC-40A-220
S85CC-8-197	S85DC-40-197
S85CC-9-200	S85DC-40-197 CM46
S85CC-9-220	S85DC-40A-220 CM46
S85CC-9-235	S85DC-40-235 CM46
S85CC-22-183	S85DC-40-190
S85CC-22-190	S85DC-40-190
S85CC-22-197	S85DC-40-197
S85CC-22-220	S85DC-40A-220
S85CC-22-235	S85DC-40-235
S85CC-22-250	S85DC-40-250
S85CC-23-220	S85DC-40A-220 CM2
S85CC-23-235	S85DC-40-235 CM4
S85DB-1-200	S85DC-40-197 CM46
S85DB-1-220	S85DC-40A-220 CM46
S85DB-1-235	S85DC-40-235 CM46
S85DB-1-250	S85DC-40-250 CM46
S85DB-2-235	S85DC-40-235 CM22
S85DB-3-200	S85DC-40-197 CM46
S85DB-3-220	S85DC-40A-220 CM46
S85DB-3-235	S85DC-40-235 CM46
S85DB-3-250	S85DC-40-250 CM46
S85DC-7-200	S85DC-40-197
S85DC-7-220	S85DC-40A-220
S85DC-7-235	S85DC-40-235
S85DC-8-220	S85DC-40A-220
S85DC-8-235	S85DC-40-235
S85DC-10-197	S85DC-40-197
S85DC-10-220	S85DC-40A-220
S85DC-11-197	S85DC-40-197
S85DC-12-220	S85DC-40A-220

COMMERCIAL HYDRAULICS

S85DC-13-210	S85DC-40A-220
S85DC-22-176	S85DC-40-170
S85DC-22-183	S85DC-40-190
S85DC-22-190	S85DC-40-190
S85DC-22-197	S85DC-40-197
S85DC-22-220	S85DC-40A-220
S85DC-22-235	S85DC-40-235
S85DC-22-250	S85DC-40-250
S85DC-23-220	S85DC-40A-220 CM4
S85DC-23-235	S85DC-40-235 CM4
S85DC-25-183	S84DC-40-180
S85DC-25-190	S85DC-40-190
S85DC-25-250	S85DC-40-250
S85DC-30-190	S85DC-40-190
S85DC-30-197	S85DC-40-197
S85DC-30-220	S85DC-40A-220
S85DC-30-235	S85DC-40-235
S85DC-30-250	S85DC-40-250
S85DC-31-190	S85DC-40-190
S85DC-35-250	S85DC-56-250
S85DC-36-250	S85DC-56-250
S85DC-36-265	S85DC-56-265
S85DC-36-280	S85DC-56-280
S85DC-40-220	S85DC-40A-220
S85DC-40-265	S85DC-40A-265
S85DC-50-250	S85DC-56-250
S85DC-50-265	S85DC-56-265
S85DC-50-280	S85DC-56-280
S85DC-52-250	S85DC-56-250
S85DC-52-265	S85DC-56-265
S85DC-52-280	S85DC-56-280
S85DC-55-250	S85DC-56-250
S85DC-55-265	S85DC-56-265
S85DC-55-280	S85DC-56-280
S85MB-2-197	S85MC-48-200
S95CC-22-190	S95DC-40-190 CM4
S95CC-22-220	S95DC-40-220 CM4
S95CC-22-235	S95DC-40-235 CM4
S95CC-22-250	S95DC-40-250 CM4
S95DC-30-220	S95DC-40-220 CM4
S95DC-30-235	S95DC-40-235 CM4
S95DC-30-250	S95DC-40-250 CM4
S95DC-30-300	S95DC-40A-300
S95DC-31-260	S95DC-40-265
S95DC-40-210	S95DC-40-220
S95DC-40-300	S95DC-40A-300
S95DC-40-320	S95DC-40A-320
S95DC-41-260	S95DC-40-265
SD42CC-10-111	SD42CC-19-111
SD42CC-13-111	SD42CC-19-111
SD43CC-4-106	SD53CC-25-106
SD52CC-19-111	SD52CC-24-111
SD52DC-6-119	SD52DC-8-119
SD53CC-28-182	SD53CC-31-182
SD53CD-1-182	SD53CD-2-182
SD62CB-10-79	SD62CB-11-79
SD62CB-10-94	SD62CB-11-94
SD62CB-10-114	SD62CB-11-114
SD63CB-5-132	SD63CB-15-132
SD63CB-5-167	SD63CB-15-167
SD63CB-6-118	SD63CB-14-118
SD63CB-11-118	SD63CB-14-118

COMMERCIAL HYDRAULICS

SD63CC-22-124	SD63CC-24-124
SD63DB-4-120	SD63DB-14-120
SD63DB-5-120	SD63DB-14-120
SD63DB-9-120	SD63DB-14-120
SD63DB-13-120	SD63DB-14-120
SD64CC-6-132	SD64CC-7-132
SD64CC-6-152	SD64CC-7-152
SD73CC-9-120	SD73CC-25-120
SD74CC-9-131	SD74CC-11-131
SD74DB-8-144	SD74DB-6-144
SD83CB-5-117	SD83CB-16-117
SD83CB-6-117	SD83CB-16-117
SD83CB-7-117	SD83CB-16-117
SD83CB-13-117	SD83CB-16-117
SD83CB-15-117	SD83CB-16-117
SD83CC-5-132	SD83CC-24-132
SD83CC-5-156	SD83CC-24-156
SD83CC-16-126	SD83CC-27-126
SD83CC-25-126	SD83CC-27-126
SD83CC-26-126	SD83CC-27-126
SD83GF-1-156	SD83GF-2-156
SD83LF-3-177	SD83LF-5-177
SD83LF-4-177	SD83LF-5-177
SD84CC-5-144	SD84CC-20-144
SD84CC-5-178	SD84CC-20-178
SD84CC-6-135	SD84CC-21-135
SD84CC-17-178	SD84CC-20-178
SD84MC-3-152	SD84MC-18-152
SD84MC-3-176	SD84MC-18-176
SD84MC-4-152	SD84MC-18-152
SD84MC-4-176	SD84MC-18-176
SD84MC-6-176	SD84MC-21-176
SD84MC-8-152	SD84MC-18-152
SD84MC-8-176	SD84MC-18-176
SD84MC-9-152	SD84MC-18-152
SD84MC-9-176	SD84MC-18-176
SD84MC-11-406	SD84MC-20-406
SD84MC-12-406	SD84MC-20-406
SD84MC-13-176	SD84MC-21-176
SD84MC-14-152	SD84MC-18-152
SD84MC-16-406	SD84MC-23-406
SD85CC-12-348	SD85CC-19-348
SD85CC-17-348	SD85CC-19-348
SD85DC-1-380	SD85DC-2-380
SD85MC-3-221	SD85MC-15-220
SD85MC-4-221	SD85MC-15-220
SD85MC-8-220	SD85MC-15-220
SD85MC-9-220	SD85MC-15-220
SD85MC-11-220	SD85MC-16-220
SD94CC-1-176	SD94CC-7-176
SD94CC-2-176	SD94CC-7-176
SD94CC-3-176	SD94CC-7-176
SD94CC-4-190	SD94CC-8-190
SD95CC-1-160	SD95CC-3-160
SD95MC-1-220	SD95MC-5-220
SD95MC-2-220	SD95MC-6-220
SD96CC-1-199	SD96CC-3-199
SD96MC-6-412	SD96MC-5-412
SD96MC-6-456	SD96MC-5-456
SD96MC-6-480	SD96MC-5-480

Crossover and Application Data is for Reference Purpose Only. No Other Conditions are Expressed or Implied.

Note: In some applications, modifications may be required for proper cylinder installation.

Quick Reference Guide

CRYSTEEL

107450	S73DC-41-129
107455	S73DC-40-150
107465	S63DC-47-130 CM2
107469	S63DC-44-111
T63113	S63DC-44-111
T63131	S63DC-47-130 CM2
T73129	S73DC-41-129
T73147	S73DC-40-150

CUSTOM HOIST

32-29-43	S32DB-1-43 CM72
42-44-60	S42MB-5-60
42-75-43	S42DB-5-43 CM72
43-2-74	S43MB-1-75
43-5-72	S43DB-2-75 CM72
53-2-60S	S53DC-14-72 CM4
53-2-72	S53DC-14-72 CM4
53-2-72S	S53DC-14-72 CM4
53-2-74	S53DC-14-72 CM4
53-2-84	S53DC-14-84 CM4
53-2-88	S53DC-14-84 CM4
53-2-90	S53DC-14-84 CM4
53-3-120	S53MB-3-120
53-12-99	S53DC-15-99
53-12-122	S53DC-15-123
53-52-120	S53DC-15-120
53-59-99	S53DC-15-99
53-59-105	S53DC-15-105
53-59-122	S53DC-15-123
53-72-60S	S53DC-14-72 CM4
53-72-72	S53DC-14-72 CM4
53-72-72S	S53DC-14-72 CM4
53-72-74	S53DC-14-72 CM4
53-72-84	S53DC-14-84 CM4
53-72-88	S53DC-14-84 CM4
53-72-90	S53DC-14-84 CM4
53-73-89	S53MB-5-90
53-80-120	S53DC-15-120
53-97-63	S53DB-2-63
53-117-60	S53DB-13-60
63-1-137	S63DC-47-130 CM43
63-1-138	S63DC-47-130 CM43
63-2-72S	S63DC-47-77 CM2
63-2-74S	S63DC-47-77 CM2
63-2-84	S63DC-47-86 CM2
63-2-84S	S63DC-47-86 CM2
63-2-87	S63DC-47-86 CM2
63-2-88	S63DC-47-86 CM2
63-2-90	S63DC-47-86 CM2
63-2-92S	S63DC-47-92
63-2-99S	S63DC-47-104 CM2
63-2-100S	S63DC-47-107 CM2
63-2-102	S63DC-47-104 CM2
63-2-105	S63DC-47-104 CM2
63-2-106	S63DC-47-107 CM2
63-2-108	S63DC-47-107 CM2
63-2-120	S63DC-47-120 CM2
63-2-126	S63DC-44-123
63-2-130	S63DC-47-130 CM2
63-2-132	S63DC-47-130 CM2
63-2-137	S63DC-47-130 CM2
63-2-140	S63DC-47-140 CM2
63-2-150	S63DC-47-150

CUSTOM HOIST

63-2-156	S63DC-47-150
63-4-104	S63MB-11-108
63-4-120	S63MB-9-120
63-4-160	S63MB-8-160
63-5-107	S63DC-47-107 CM38
63-5-125	S63DC-47-126 CM38
63-8-80	S63DC-47-77 CM11
63-8-82	S63DC-47-82 CM11
63-8-86	S63DC-47-86 CM11
63-8-104	S63DC-47-104 CM11
63-8-111	S63DC-44-111 CM11
63-8-123	S63DC-44-123 CM11
63-8-130	S63DC-47-126 CM11
63-8-140	S63DC-47-140 CM11
63-10-120	S63DC-45-120
63-10-127	S63DC-45-126
63-21-108	S63DC-47-107 CM36
63-23-98	S63DC-47-104 CM36
63-27-121	S63DC-45-120
63-27-125	S63DC-45-126
63-27-139	S63DC-45-138
63-27-160	S63DC-45-162
63-44-120	S63DC-47-120 CM2
63-44-130	S63DC-47-130 CM2
63-44-140	S63DC-47-140 CM2
63-53-130	S63DC-47-130 CM2
63-54-108	S63DC-47-107 CM2
63-83-108	S63DC-47-107 CM38
63-83-126	S63DC-47-126 CM38
63-105-110	S63DC-47-107 CM17
63-105-142	S63DC-47-140 CM17
63-105-144	S63DC-47-140 CM17
63-157-80	S63DC-47-77 CM22
63-172-108	S63DC-47-107 CM38
63-172-126	S63DC-47-126 CM38
63-180-104	S63DC-47-104
63-184-111	S63DC-44-111 CM11
63-184-123	S63DC-44-123 CM11
63-184-140	S63DC-47-140 CM11
63-186-121	S63DC-45-120
63-186-125	S63DC-45-126
63-186-139	S63DC-45-138
63-186-160	S63DC-45-162
63-189-130	S63DC-47-130 CM2
63-189-140	S63DC-47-140 CM2
63-202-121	S63DC-45-120
63-202-125	S63DC-45-126
63-202-139	S63DC-45-138
63-402-132	S63DC-47-130 CM2
64-35-135	S64DB-6-135
64-35-156	S64DB-6-156
73-1-127	S73DC-40-124 CM23
73-1-142	S73DC-40-140 CM23
73-2-120	S73DC-40-120
73-3-120	S73DC-40-120
73-3-130	S73DC-41-129
73-3-140	S73DC-40-140
73-9-129	S73DC-40-124 CM11
73-9-130	S73DC-41-129 CM11
73-15-130	S73DC-41-129
73-15-135	S73DC-41-129
73-21-120	S73DC-40-120 CM4
73-22-120	S73DC-40-120 CM4
73-26-120	S73DC-40-120

CUSTOM HOIST

73-44-120S	S73DC-40-124
73-50-130	S73DC-41-129
73-55-126	S73DC-40-124
73-57-125	S73DC-40-124 CM38
73-78-142	S73DC-40-140 CM38
73-81-114	S73DC-40-110 CM26
73-81-129	S73DC-40-124 CM26
73-108-130	S73DC-41-129
74-1-118	S74DC-40A-120
74-1-120	S74DC-40A-120
74-1-124S	S74DC-40-135
74-1-126	S74DC-40A-120
74-1-135	S74DC-40-135
74-1-137	S74DC-40-135
74-1-138	S74DC-40-135
74-1-140S	S74DC-40A-140
74-1-144	S74DC-40A-140
74-1-146	S74DC-40A-140
74-1-160	S74DC-40-156
74-7-135	S74DC-41-135
74-10-123	S74DC-40A-120 CM11
74-10-135	S74DC-40-135 CM11
74-10-142	S74DC-40A-140 CM11
74-12-120	S74DC-40A-120
74-27-156	S74DC-40-156 CM4
74-28-120	S74DC-40A-120
74-28-137	S74DC-40-135
74-28-161	S74DC-40-161
74-34-120	S74DC-40A-120 CM4
74-34-137	S74DC-40-135 CM2
74-34-144	S74DC-40A-140 CM4
74-37-160	S74DC-40-156
74-42-118	S74DC-40A-120
74-42-120	S74DC-40A-120
74-42-124S	S74DC-40-135
74-42-126	S74DC-40A-120
74-42-137	S74DC-40-135
74-42-138	S74DC-40-135
74-42-140S	S74DC-40A-140
74-42-144	S74DC-40A-140
74-42-146	S74DC-40A-140
74-42-160	S74DC-40-156
74-65-154	S74MB-3-154
74-65-170	S74MB-3-172
83-4-140	S83DC-40-139
84-2-150	S84DC-40-148
84-2-160	S84DC-31-156
84-2-165	S84DC-40-161
84-2-174	S84DC-40-170
84-2-181	S84DC-40-180
84-2-190	S84DC-40-188
84-4-140	S84DC-40-140
84-4-166	S84DC-40-161
84-4-180	S84DC-40-180
84-7-180	S84DC-40-180 CM21
84-13-135S	S84DC-40-140
84-13-148	S84DC-40-148
84-13-150	S84DC-40-148
84-13-150S	S84DC-31-156
84-13-156S	S84DC-40-161
84-13-160	S84DC-31-156
84-13-166	S84DC-40-161
84-13-190	S84DC-40-188

Crossover and Application Data is for Reference Purpose Only. No Other Conditions are Expressed or Implied.

Note: In some applications, modifications may be required for proper cylinder installation.

Quick Reference Guide

CUSTOM HOIST

84-20-150	S84DC-40-148
84-20-175	S84DC-40-170
84-23-190	S84DC-40-188
84-36-135S	S84DC-40-140
84-36-148	S84DC-40-148
84-36-150	S84DC-40-148
84-36-150S	S84DC-31-156
84-36-156S	S84DC-40-161
84-36-160	S84DC-31-156
84-36-166	S84DC-40-161
84-36-190	S84DC-40-188
85-2-166	S85DC-51-160
85-2-170	S85DC-40-170
85-2-200	S85DC-40-197
85-2-200S	S85DC-40-197
85-2-225	S85DC-40A-220
85-2-235	S85DC-40-235
85-2-265	S85DC-40A-265
85-2-285	S85DC-40-285
85-3-203	S85DC-40-197 CM46
85-3-235	S85DC-40-235 CM46
85-3-265	S85DC-40A-265 CM46
85-6-162	S85DC-51-160
85-6-265	S85DC-40A-265
85-11-162	S85DC-51-160
85-11-170	S85DC-40-170
85-11-200	S85DC-40-197
85-11-235	S85DC-40-235
85-11-265	S85DC-40A-265
85-11-285	S85DC-40-285
85-16-162	S85DC-51-160
85-16-235	S85DC-40-235
85-20-220	S85DC-40A-220
85-20-235	S85DC-40-235
85-20-265	S85DC-40A-265
85-20-285	S85DC-40-285
85-28-170	S85DC-40-170
85-28-235	S85DC-40-235
85-28-250	S85DC-40-250
85-28-265	S85DC-40A-265
85-28-289	S85DC-40-285
85-34-162	S85DC-51-160
85-34-170	S85DC-40-170
85-34-200	S85DC-40-197
85-34-220	S85DC-40A-220
85-34-235	S85DC-40-235
85-34-265	S85DC-40A-265
85-35-220	S85DC-40A-220 CM54
85-35-235	S85DC-40-235 CM54
85-43-160	S85DC-51-160
85-43-166	S85DC-51-160
85-43-170	S85DC-40-170
85-43-200	S85DC-40-197
85-43-200S	S85DC-40-197
85-43-225	S85DC-40A-220
85-43-235	S85DC-40-235
85-43-265	S85DC-40A-265
85-43-285	S85DC-40-285
85-58-203	S85DC-40-197 CM46
85-58-235	S85DC-40-235 CM46
85-58-265	S85DC-40A-265 CM46
85-402-170	S85DC-40-170
85-402-200	S85DC-40-197
85-402-235	S85DC-40-235

CUSTOM HOIST

95-3-235	S95DC-40-235 CM9
95-3-250	S95DC-40-250 CM9
95-3-260	S95DC-40-265 CM9
95-4-235	S95DC-40-235
95-4-236	S95DC-40-235
95-4-250	S95DC-40-250
95-4-285	S95DC-40-280
95-6-235	S95DC-40-235 CM42
95-6-250	S95DC-40-250 CM42
95-6-270	S95DC-40-265 CM42
95-11-190S	S95DC-40-190
95-11-200	S95DC-40-190
95-11-235	S95DC-40-235
95-11-250	S95DC-40-250
95-11-260	S95DC-40-265
95-11-260S	S95DC-40-265
95-11-264S	S95DC-40-265
95-11-265	S95DC-40-265
95-11-265S	S95DC-40-265
95-11-280	S95DC-40-280
95-11-285	S95DC-40-280
95-11-300	S95DC-40A-300
95-21-190S	S95DC-40-190
95-21-200	S95DC-40-190
95-21-250	S95DC-40-250
95-21-260	S95DC-40-265
95-21-260S	S95DC-40-265
95-21-264S	S95DC-40-265
95-21-265	S95DC-40-265
95-21-265S	S95DC-40-265
95-21-280	S95DC-40-280
95-21-285	S95DC-40-280
95-21-300	S95DC-40A-300
95-54-260	S95DC-40-265 CM9
96-11-285	S96DC-1-285
9 3/4 5-4-235	S95DC-40-235
9 3/4 5-4-250	S95DC-40-250
9 3/4 5-4-260	S95DC-40-265
9 3/4 5-4-265	S95DC-40-265
9 3/4 5-4-280	S95DC-40-280
9 3/4 5-4-300	S95DC-40A-300
DA3-72-25.5	C4438
DA3-81-25	C4439
DA3 1/2-24-22	B3151
DA4-61-24	C3808
DA4-128-35	C3863
DA4-142-21	C3847
DA4-230-29	C3831
DA4 1/2-21-26	C3850
DA4 1/2-22-27	B3152
DA4 1/2-52-41	C3933
DA5-119-51	C3694
DA5-144-36	C3872
DA5-47-27	C3805
DA5-53-20	C3843
DA5 1/2-33-54	C3563
DA5 1/2-35-63	D4088
DA5 1/2-51-63	C4793
DA6-14-76	D3838
DA6-36-76	D3838
DA6-96-72	D60DB-7-72
DA6-100-63	D3855

CUSTOM HOIST

DA6-171-69	D60DD-4-69
DA6 1/2-33-80	D62LB-5-80
DA7-5-108	D70CC-8-108
DA7-5-131	D70CC-8-131
DA7-107-80	D70LN-2-80
DA7-182-108	D70CC-8-108
DA7-182-131	D70CC-8-131
DA7-241-80	D70LN-2-80
DA7 1/4-1-80	D72LB-9-80
DAT42-19-112	SD42CC-19-111
DAT42-58-112	SD42CC-19-111
DAT43-4-106	SD53CC-25-106
DAT52-9-119	SD52DC-8-119
DAT52-24-112	SD52CC-24-111
DAT52-32-119	SD52DC-8-119
DAT52-58-119	SD52DC-8-119
DAT53-8-110	SD53CC-16-111
DAT53-105-110	SD53CC-16-111
DAT53-117-182	SD53CD-2-182
DAT53-125-182	SD53CC-31-182
DAT53-130-110	SD53CC-16-111
DAT54-3-150	SD64CC-7-152
DAT54-4-118	SD64CC-7-118
DAT54-4-136	SD64CC-7-132
DAT54-5-135	SD64CC-7-132
DAT54-8-118	SD64CC-7-118
DAT54-8-136	SD64CC-7-132
DAT62-1-79	SD62CB-11-79
DAT62-1-94	SD62CB-11-94
DAT62-1-114	SD62CB-11-114
DAT62-2-79	SD62CB-11-79
DAT62-2-94	SD62CB-11-94
DAT62-2-114	SD62CB-11-114
DAT62-16-82	SD62CC-20-82
DAT62-31-114	SD62CB-11-114
DAT62-31-79	SD62CB-11-79
DAT62-55-79	SD62CB-11-79
DAT62-55-94	SD62CB-11-94
DAT62-55-114	SD62CB-11-114
DAT62-58-82	SD62CC-20-82
DAT63-2-118	SD63CB-14-118
DAT63-7-118	SD63CB-14-118
DAT63-9-73	SD63CC-11-73
DAT63-9-97	SD63CC-11-96
DAT63-14-120	SD63DB-14-120
DAT63-27-93	SD63DB-6-93
DAT63-27-108	SD63DB-6-108
DAT63-27-132	SD63DB-7-132
DAT63-28-73	SD63CC-11-73
DAT63-28-97	SD63CC-11-96
DAT63-35-120	SD63DB-10-120
DAT63-37-120	SD63DB-14-120
DAT63-38-118	SD63CB-14-118
DAT63-49-124	SD63CC-24-124
DAT63-55-124	SD63CC-24-124
DAT63-63-120	SD63DB-14-120
DAT63-67-118	SD63CB-14-118
DAT63-79-93	SD63DB-6-93
DAT63-84-152	SD63DB-11-152
DAT63-92-124	SD63CC-24-124
DAT63-95-133	SD63CB-15-132
DAT63-95-167	SD63CB-15-167

Crossover and Application Data is for Reference Purpose Only. No Other Conditions are Expressed or Implied.

Note: In some applications, modifications may be required for proper cylinder installation.

Quick Reference Guide

CUSTOM HOIST

DAT63-139-124 SD63CC-24-124
DAT63-145-118 SD63CB-14-118
DAT63-146-120 SD63DB-14-120
DAT63-147-73 SD63CC-11-73
DAT63-147-97 SD63CC-11-96
DAT63-151-152 SD63DB-11-152
DAT63-155-118 SD63CB-14-118
DAT63-157-118 SD63CB-14-118
DAT63-176-120 SD63DB-10-120
DAT63-182-93 SD63DB-6-93
DAT63-182-108 SD63DB-6-108
DAT63-182-132 SD63DB-7-132
DAT63-209-118 SD63CB-14-118
DAT64-31-136 SD64CC-7-132

DAT72-18-156 SD72AC-1-156
DAT72-22-156 SD72AC-1-156
DAT72-30-156 SD72AC-1-156
DAT73-11-156 SD73GF-2-156
DAT73-20-120 SD73CC-25-120
DAT74-6-131 SD74CC-11-131
DAT74-11-144 SD74DB-6-144
DAT74-15-144 SD74DB-6-144
DAT74-21-171 SD74DB-4-171
DAT74-22-144 SD74DB-6-144
DAT74-28-163 SD74CC-14-163
DAT74-57-144 SD74DB-6-144
DAT74-72-132 SD74CC-11-131
DAT74-73-144 SD74DB-6-144
DAT74-113-144 SD74DB-6-144

DAT83-6-126 SD83CC-27-126
DAT83-27-126 SD83CC-27-126
DAT84-13-176 SD84MC-21-176
DAT84-14-152 SD84MC-18-152
DAT84-14-176 SD84MC-18-176
DAT84-18-406 SD84MC-20-406
DAT84-19-406 SD84MC-23-406
DAT84-23-135 SD84CC-21-135
DAT84-28-406 SD84MC-20-406
DAT84-29-406 SD84MC-23-406
DAT84-38-145 SD84CC-20-144
DAT84-38-178 SD84CC-20-178
DAT84-43-145 SD84CC-20-144
DAT84-43-178 SD84CC-20-178
DAT84-48-176 SD84MC-21-176
DAT84-57-145 SD84CC-20-144
DAT84-57-178 SD84CC-20-178
DAT84-68-176 SD84MC-21-176
DAT84-70-406 SD84MC-23-406
DAT85-9-384 SD85MC-20-384
DAT85-11-348 SD85CC-19-348
DAT85-15-384 SD85MC-20-384
DAT85-18-380 SD85DC-2-380
DAT85-25-348 SD85CC-19-348
DAT85-26-220 SD85MC-16-220
DAT85-27-220 SD85MC-15-220
DAT85-29-384 SD85MC-20-384
DAT85-45-384 SD85MC-20-384
DAT85-46-220 SD85MC-16-220
DAT85-47-220 SD85MC-15-220
DAT85-50-348 SD85CC-19-348
DAT85-53-384 SD85MC-20-384
DAT85-58-348 SD85CC-19-348
DAT85-61-380 SD85DC-2-380

CUSTOM HOIST

DAT85-65-380 SD85DC-2-380
DAT85-72-378 SD85CC-19-378
DAT85-93-220 SD85MC-16-220
DAT85-94-220 SD85MC-15-220
DAT86-3-177 SD86CC-2-177
DAT94-7-190 SD94CC-8-190
DAT95-21-220 SD95MC-5-220
DAT95-22-220 SD95MC-5-220
DAT95-27-220 SD95MC-6-220
DAT95-32-160 SD95CC-3-160
DAT95-34-220 SD95MC-6-220
DAT95-35-220 SD95MC-5-220
DAT95-36-220 SD95MC-5-220
DAT96-3-412 SD96MC-5-412
DAT96-3-416 SD96MC-5-412
DAT96-3-456 SD96MC-5-456
DAT96-4-198 SD96CC-3-199
DAT96-4-199 SD96CC-3-199
DAT96-6-412 SD96MC-5-412
DAT96-6-416 SD96MC-5-412
DAT96-6-456 SD96MC-5-456
DAT96-10-200 SD96CC-3-199
DAT96-15-412 SD96MC-5-412
DAT96-15-456 SD96MC-5-456
DAT96-15-480 SD96MC-5-480
DAT96-16-412 SD96MC-5-412
DAT96-16-456 SD96MC-5-456
DAT96-16-480 SD96MC-5-480
DAT96-17-200 SD96CC-3-199
DAT96-26-199 SD96CC-3-199
DAT96-27-200 SD96CC-3-199
DAT96-28-456 SD96MC-5-456
DAT96-28-480 SD96MC-5-480
DAT96-29-456 SD96MC-5-456
DAT96-29-480 SD96MC-5-480
DAT96-37-412 SD96MC-5-412
DAT96-37-456 SD96MC-5-456
DAT96-37-480 SD96MC-5-480
DAT96-38-412 SD96MC-5-412
DAT96-38-456 SD96MC-5-456
DAT96-38-480 SD96MC-5-480
DAT96-41-412 SD96MC-5-412
DAT96-41-456 SD96MC-5-456
DAT96-41-480 SD96MC-5-480
DAT96-45-412 SD96MC-5-412
DAT96-45-456 SD96MC-5-456
DAT96-47-412 SD96MC-5-412
DAT96-47-456 SD96MC-5-456
DAT96-47-480 SD96MC-5-480
DAT96-48-412 SD96MC-5-412
DAT96-48-456 SD96MC-5-456
DAT96-48-480 SD96MC-5-480
DAT96-49-456 SD96MC-5-456
DAT96-50-412 SD96MC-5-412
DAT96-50-456 SD96MC-5-456
DAT96-50-480 SD96MC-5-480
DAT96-52-412 SD96MC-5-412
DAT96-52-456 SD96MC-5-456
DAT96-59-170 SD86CC-1-171

DAT9 3/4 4H-10-190 ... SD94CC-8-190
DAT9 3/4 4H-3-190 SD94CC-8-190
DAT9 3/4 4H-8-189 SD94CC-8-190
DAT9 3/4 6-2-200 SD96CC-3-199
DAT9 3/4 6-3-200 SD96CC-3-199

CUSTOM HOIST

DAT9 3/4 6-6-199 SD96CC-3-199
DAT9 3/4 6-7-199 SD96CC-3-199
DAT9 3/4 6-8-199 SD96CC-3-199

SA2 1/2-3-31 B5347
SA3 1/2-1-37 C3842
SA3 1/2-16-25 C3877

DEMPSTER

AB15905 SD96CC-3-199
AB17404 SD85CC-19-348
AB17564 SD74CC-11-131
AB17924 SD63CC-11-96
AB19461 D3838
AB19473 SD94CC-8-190
AB19553 SD86CC-2-177
AB19600TH C3814
AB19601TH C3805
AB19602TH C3842
AB26635TH C3810
AB28805 SD63CD-1-177
BB6087 SD63CC-11-96
BB6089 SD74CC-11-131
BB6199 SD63CC-11-96
BB6200 SD74CC-11-131
BB6201 SD63CC-11-73
BB6888 C3842
BB6996 C3805
BB6997 C3814
BB8112 C3814
BB8133-1 C3814
BB8134-1 C3805
BB8169 C3808
BB8235 C3805
BB8281-1 C3842
BB8748-1 C3808
BB9042 SD86CC-2-177
BB9290 D3838
CB3618 SD85CC-19-348
CB4753 SD96CC-3-199
CB5968 SD85CC-19-348
CB7015 SD53CC-16-111
CB7478 SD72AC-1-156
CB7599 SD96CC-3-199
CB7661 SD72AC-1-156
CB7770 SD63CC-11-96
CB7771 SD74CC-11-131
CB7772 SD63CC-11-73
CB7781 SD53CC-16-111
CB7877 SD72AC-1-156
CB7947 SD72AC-1-156
CB8217 SD96CC-3-199
CB8321 SD85CC-19-348
DB1748 SD96CC-3-199
DB4753 SD96CC-3-199
DB5801 SD96CC-3-199
DB7694 D3838
DB8042 C3805
DB8043 C3810
DB8044 C3842
DB8045 SD94CC-9-190
DB8809 S52DC-7-88
DB9135 S52DC-7-88
DB9350 SD74CC-11-131
DB9361 SD63CD-1-177

Crossover and Application Data is for Reference Purpose Only. No Other Conditions are Expressed or Implied.

Note: In some applications, modifications may be required for proper cylinder installation.

Quick Reference Guide

ENERGY

A277 D60DB-7-72
A3525 D70LN-2-80
A6430 D60DB-7-72

EDBRO

058003223 S53DC-11-104
058003247 S53DC-11-120
058003401 S63DC-47-107
058003440 S63DC-44-111
058003488 S63DC-47-140
058003820 S85DC-40-235
TE11-3-2660 S53DC-11-104
TE11-3-2960 S53DC-11-120
TE14-3-2670 S63DC-47-107
TE14-3-2850 S63DC-44-111
TE14-3-3450 S63DC-47-140
TE18-5-6170 S85DC-40-235

FONTAINE

5385 S53DB-13-90
53110 S53DC-11-107 CM27
6385 S63DC-47-86 CM17
6397 S63DC-47-92 CM17
63110 S63DC-47-107 CM17
63126 S63DC-44-123 CM63
63142 S63DC-47-140 CM17
73110 S73DC-40-110 CM20
73115 S73DC-40-110 CM20
73126 S73DC-40-124 CM20
73142 S73DC-40-140 CM20
84142 S84DC-40-140 CM20
84152 S84DC-40-148 CM20
84164 S84DC-31-156 CM20
84172 S84DC-40-170 CM20
84188 S84DC-40-180 CM20
85172 S85DC-51-160 CM18
85197 S85DC-40-190 CM53
DCH-31-351 S85DC-40-190 CM53
DCH-31-359 S85DC-51-160 CM18
DCH-31-374 S84DC-31-156 CM20
DCH-31-388 S84DC-40-148 CM20
DCH-31-413 S84DC-40-170 CM20
DCH-31-427 S73DC-40-140 CM20
DCH-31-433 S73DC-40-124 CM20
DCH-31-439 S73DC-40-110 CM20
DCH-31-462 S84DC-40-140 CM20
DCH-31-476 S63DC-47-140 CM17
DCH-31-483 S63DC-44-123 CM63
DCH-31-487 S63DC-47-107 CM17
DCH-31-491 S63DC-47-92 CM17
DCH-31-495 S63DC-47-86 CM17
DCH-31-499 S53DC-11-107 CM27
DCH-31-507 S53DB-13-90
DCH-31-519 S84DC-40-180 CM20
DCH-31-536 S73DC-40-110 CM20

FRUEHAUF

251147 S84DC-40-170
ECA-8950 S85MC-48-220
ECA-8951 S85MC-48-235
ECA-9287 S85MC-48-200
ECB-2353 X S85DC-40-235
ECB-2353-1 S85DC-40A-220
ECB-2353-2 S85DC-40-190
ECB-2353-3 S84DC-40-148
ECB-2353-5 S85DC-40-250 CM2
ECB-2353-6 S85DC-40-235 CM2
ECB-2353-7 S85DC-40A-220 CM2
ECB-2353-8 S85DC-40-190 CM2
ECB-2353-9 S85DC-40-250
ECB-2353-10 S85DC-40-170
ECB-2353-12 S84DC-31-156
ECB-2353-13 S73DC-40-120 CM4
ECB-2353-14 S74DC-40-156 CM4
ECB-2353-15 S63DC-47-120 CM36
ECB-2353-17 S84DC-40-140
ECB-2353-18 S74DC-40A-140 CM4
ECB-2353-19 S84DC-40-148 CM2
ECB-2353-20 S63DC-47-107 CM36
ECB-2353-21 S63DC-47-104 CM36
ECB-2353-22 S84DC-40-140
ECB-2353-23 S95DC-40-250
ECB-2353-24 S95DC-40-265
ECB-2353-25 S85DC-40-250
ECB-2353-26 S85DC-40-235
ECB-2353-27 S85DC-40A-220
ECB-2353-28 S95DC-40-250
ECB-2353-29 S85DC-40A-265
ECB-2353-30 S85DC-40-235 CM2
ECB-2353-31 S85DC-40-250 CM2
ECB-2353-32 S85DC-40A-265 CM2
ECB-2353-33 S95DC-40-265
ECB-2353-35 S96DC-1-285
ECB-2353-37 S85DC-40A-265 CM2
ECB-2353-38 S84DC-40-148
ECB-2353-39 S85DC-40A-265
ECB-2353-41 S63DC-47-120 CM36
ECB-2353-42 S85DC-40-190
ECB-2353-43 S85DC-40-190 CM2
ECB-2353-44 S85DC-40A-220 CM2
ECB-2353-45 S96DC-1-285
ECB-2353-46 S95DC-40-250 CM42
ECB-2353-47 S95DC-40-220
ECB-2353-48 S95DC-40-235
ECB-2353-52 S95DC-40-280
ECB-2353-53 S95DC-40-250 CM42
ECB-2353-54 S85DC-40-190
ECB-2353-55 S85DC-40A-220
ECB-2353-56 S85DC-40-190 CM2
ECB-2353-57 S85DC-40A-220 CM2
ECB-2353-101 S85DC-40A-220
ECB-2353-706 S85DC-40-235
ECC-3366-1 S63DC-47-107 CM16
ECC-3366-2 S63DC-47-120 CM16
ECC-3366-3 S63DC-47-130 CM16
ECE-7681-1 S84DC-31-156
ECE-7681-2 S73DC-40-120 CM4
ECE-7681-3 S74DC-40-156 CM4
ECE-7681-4 S63DC-47-120 CM36
ECE-7681-5 S84DC-40-140
ECE-7681-6 S74DC-40A-140 CM4
ECE-7681-7 S63DC-47-107 CM36
ECE-7681-8 S74DC-40A-140 CM4
MCU-007401-140 S74DC-40A-140
MCU-008413-170 S84DC-40-170
MCU-008502-190 S85DC-40-190
MCU-008520-250 S85DC-40-250
MHC-030656 S53MB-3-120
MHC-030657 S95DC-40-235 CM42
MHC-030663 S84DC-31-156

FRUEHAUF

MHC-030665 S95DC-40-190 CM42
MHC-030666 S84DC-40-170
MHC-030667 SD63DB-14-120
MHC-030668 S95DC-40-220 CM42
MHC-030671 S74DC-40-135 CM4
MHC-030673 S63MB-8-140
MHC-030676 S85DC-40A-265
MHC-030680 S74DC-41-135
MHC-030682 S74DC-40A-120 CM4
MHC-030684 S95DC-40-250 CM42
MHC-030685 S63MB-11-108
MHC-030686 S85DC-40-190
MHC-030692 S73DC-40-140 CM4

TWC-1391-X S85DC-40-235
TWC-1391-1 S85DC-40A-220
TWC-1391-2 S85DC-40-190
TWC-1391-3 S84DC-40-148
TWC-1391-5 S85DC-40-250 CM2
TWC-1391-6 S85DC-40-235 CM2
TWC-1391-7 S85DC-40A-220 CM2
TWC-1391-8 S85DC-40-190 CM2
TWC-1391-9 S85DC-40-250
TWC-1391-10 S85DC-40-170
TWC-1391-12 S84DC-31-156
TWC-1391-13 S73DC-40-120 CM4
TWC-1391-14 S74DC-40-156 CM4
TWC-1391-15 S63DC-47-120 CM36
TWC-1391-17 S84DC-40-140
TWC-1391-18 S74DC-40A-140 CM2
TWC-1391-19 S84DC-40-148 CM2
TWC-1391-20 S63DC-47-107 CM36
TWC-1391-21 S63DC-47-104 CM36
TWC-1391-22 S84DC-40-140
TWC-1391-23 S95DC-40-250
TWC-1391-29 S85DC-40A-265
TWC-1392-X S85DC-40-235
TWC-1392-2 S85DC-40-190
TWC-1392-3 S84DC-40-148
TWC-1392-9 S85DC-40-250
TWC-1411-1 S84DC-31-156
TWC-1411-2 S73DC-40-120 CM4
TWC-1411-3 S74DC-40-156 CM4
TWC-1411-4 S63DC-47-120 CM36
TWC-1411-5 S84DC-40-140
TWC-1411-6 S74DC-40-135 CM4
TWC-1411-7 S63DC-47-107 CM36

GALBREATH

1039 D60DB-7-72
1043 D60DB-7-72
1111 SD63CB-14-118
1126 D60DB-7-72
2419 SD62CB-11-114
2420 SD62CB-11-79
2460 D70LN-2-80
2494 SD62CB-11-94
3116 SD62CB-11-114
3131 SD62CB-11-94
3139 SD62CB-11-114
3242 SD62CB-11-94
3412 D60DB-7-72
3902 SD62CB-11-114
8973 SD62CB-11-79
9920 D60DB-7-72

Crossover and Application Data is for Reference Purpose Only. No Other Conditions are Expressed or Implied.

Note: In some applications, modifications may be required for proper cylinder installation.

Quick Reference Guide

GALBREATH

9921	D70LN-2-80
A1002	S84DC-40-188
A1056	SD85CC-19-378
A1206	S85DC-40A-265
A1527	D60DB-7-72
A1529	D70LN-2-80
A1540	S85DC-40-235
A1587	S95DC-40A-300
A1606	SD63CB-14-118
A1717	D70LN-2-80
A1745	SD63CB-14-118
A1825	S84DC-40-148
A1826	S84DC-40-170
A1827	S85DC-40-190
A1828	S85DC-40A-220
A1829	S85DC-40-235
A1830	S85DC-40-250
A1831	S85DC-40A-265
A1897	D70LN-2-80
A1905	S95DC-40-235
A1961	S95DC-40-220
A1968	D70LN-2-80
A2083	SD62CB-11-114
A2212	SD62CB-11-79
A2213	SD62CB-11-94
A2349	S85DC-40-285
A2564	S95DC-40-250
A2870	S85DC-40-285

GARWOOD

207-2368	C3843
207-3611	SD63DB-6-108
207-3613	SD63DB-6-93
207-3614	SD63DB-7-132
207-9064	SD74DB-4-171
207-9197	C3843
207-9470	C3843

HEIL

1-1281	SD53CC-25-106
1-1344	SD64CC-7-132
1-1766	S53DC-15-105
1-1972	S53DC-15-99
1-1973	S53DC-15-120
1-1974	S53DC-15-123
1-2043	S63DC-45-120
1-2044	S63DC-45-126
1-2123	SD64CC-7-152
1-2298	S63DC-45-138
1-2624	S63DC-45-162
1-2634	S63DC-45-162
1-2928	B3152
1-2931	B3151
1-3008	B5347
1-3058	S53DC-15-120
1-3139	S53DC-15-123
1-3140	S53DC-15-99
1-3141	S53DC-15-105
1-3177	S63DC-45-120
1-3178	S63DC-45-126
1-3179	S63DC-45-138
1-3180	S63DC-45-162
1-3391	SD64CC-7-118
1-3484	S53DC-15-105
1-3623	B5347

HEIL

1-3635	B3152
1-3672	B3151
1-3689	SD96CC-3-199
1-3690	D3855
1-3705	D3855
1-3809	B3152
1-3830	SD64CC-7-132
1-3834	SD53CC-25-106
1-3836	SD64CC-7-118
1-3843	SD64CC-7-152
1-3856	B3151
1-3860	S53DC-15-123
1-3871	SD64CC-7-132
1-3887	S53DC-15-99
1-3888	S53DC-15-105
1-3889	S53DC-15-120
1-3890	S53DC-15-123
1-3891	S63DC-45-120
1-3892	S63DC-45-126
1-3893	S63DC-45-138
1-3902	B3151
1-3921	B3152
1-3983	S53DC-15-99
1-3984	S53DC-15-105
1-3985	S53DC-15-120
1-3986	S53DC-15-123
1-3998	S63DC-45-120
1-3999	S63DC-45-126
1-4000	S63DC-45-138
1-4001	S63DC-45-162
1-4017	B3151
1-4018	B3152
1-4050	SD64CC-7-132
1-4052	SD53CC-25-106
1-4053	SD64CC-7-118
1-4054	SD64CC-7-152
1-4070	B5347
1-4081	C3850
1-4094	C3843
1-4100	B3151
1-4101	B3152
1-4108	C3847
1-4110	C3850
1-4123	C4438
1-4137	S53DC-15-99
1-4138	S53DC-15-105
1-4139	S53DC-15-120
1-4140	S53DC-15-123
1-4141	S63DC-45-120
1-4142	S63DC-45-126
1-4143	S63DC-45-138
1-4144	S63DC-45-162
1-4261	SD63DB-7-132
1-4266	SD63DB-6-108
1-4267	SD63DB-6-93
1-4270	SD74DB-4-171
1-4276	C3602
1-4277	C3603
1-4298	C3563
1-4305	C4438
1-4327	C3603
1-4328	D3855
1-4334	C3847
1-4338	C3576
1-4343	SD74DB-4-171
1-4348	C3877

HEIL

1-4821	SD74DB-4-171
1-4824	C3872
1-4828	C3872
1-4870	C4439
1-4871	C3933
1-4878	C3563
1-4881	SD53CD-2-182
1-4882	D4088
1-4884	C3872
1-4911	SD53CD-2-182
1-5088	B5162
1-5110	C3872
1-5112	SD53CC-31-182
1-5146	C4793
1-5147	SD53CC-31-182
1-5150	C4622
1-6076	SD53CC-31-182
1-6099	SD53CD-2-182
1-6247	SD53CC-31-182
1-6255	SD53CD-2-182

HYCO

10000-84-140	S84DC-40-140
10000-84-148	S84DC-40-148
10000-84-156	S84DC-31-156
10000-84-175	S84DC-40-170
10000-85-190	S85DC-40-190
10000-85-220	S85DC-40A-220
10001-85-235	S85DC-40-235
10001-85-250	S85DC-40-250
10002-73-120	S73DC-40-120 CM4
10002-74-140	S74DC-40A-140 CM4
10002-74-156	S74DC-40-156 CM4
10003-63-98	S63DC-47-104 CM36
10003-63-108	S63DC-47-107 CM36
10003-63-120	S63DC-47-120 CM36
10023-85-200	S85DC-40-197 CM46
10023-85-220	S85DC-40A-220 CM46
10027-63-108	S63DC-47-107
10029-85-235	S85DC-40-235
10029-85-250	S85DC-40-250
10042-85-170	S85DC-40-170
10050-74-135	S74DC-41-135
10050-74-140	S74DC-41-135
10076-63-120	S63DC-47-120 CM16
10156-935-190	S95DC-40-190 CM42
10156-935-220	S95DC-40-220 CM42
10156-935-235	S95DC-40-235 CM42
10156-935-250	S95DC-40-250 CM42
1109A-87654-235	S85MC-48-235
1139A-543-119	S53MB-3-120
1139A-543-120	S53MB-3-120
1139A-654-104	S63MB-11-108
1139A-654-108	S63MB-11-108
1139A-654-110	S63MB-11-108
1139A-654-119	S63MB-9-120
1139A-6543-140	S64MB-4-140
1221A-7654-119	S74DC-40A-120
1221A-7654-137	S74DC-40-135
1221A-87654-166	S85DC-40-170
1221A-87654-195	S85DC-40-190
1296A-975-8765-190	S95DC-40-190 CM42
1296A-975-8765-220	S95DC-40-220 CM42
1296A-975-8765-235	S95DC-40-235 CM42
1296A-975-8765-250	S95DC-40-250 CM42

Crossover and Application Data is for Reference Purpose Only. No Other Conditions are Expressed or Implied.

Note: In some applications, modifications may be required for proper cylinder installation.

Quick Reference Guide

HYCO

1315A-87654-235 S85DC-40-235
1317A-8765-150 S84DC-40-148
1317A-8765-175 S84DC-40-170
1317A-87654-190 S85DC-40-190
1317A-87654-220 S85DC-40A-220
1325A-825-765-182 S84DC-40-180
1395A-8765-148 S84DC-40-148 CM21
1395A-8765-160 S84DC-31-156 CM21
1395A-8765-164 S84DC-40-161 CM21
1395A-8765-180 S84DC-40-180 CM21
1395A-8765-182 S84DC-40-180 CM21
1395A-87654-195 S85DC-40-190 CM21
1395A-87654-220 S85DC-40A-220 CM21
1503A-7654-119 S74DC-40A-120 CM26
1503A-7654-135 S74DC-40-135 CM26
1503A-8765-153 S84DC-40-148 CM19
1542A-87654-250 S85DC-40-250
1548A-654-119 S63DC-47-120 CM16
1584A-87654-170 S85DC-40-170
1614A-765-156 SD73GF-2-156
1634A-87654-348 SD85CC-19-348
1741A-87654-220 S85DC-40A-220
1761A-654-120 SD63DB-14-120
1913A-654-108 S63DC-47-107 CM36
1913A-654-120 S63DC-47-120 CM36
1913A-765-120 S73DC-40-120 CM4
1913A-7654-141 S74DC-40A-140 CM4
1913A-7654-156 S74DC-40-156 CM4
1913A-8765-141 S84DC-40-140
1913A-8765-156 S84DC-40-156
1920A-7654-135 S74DC-41-135
1920A-7654-140 S74DC-41-135
1936A-765-140 S73DC-40-140
1942A-8765-156 S84DC-31-156
1942A-8765-190 S84DC-40-188
1967A-8765-138 S84DC-40-140 CM38
1967A-8765-152 S84DC-31-156 CM38
1967A-8765-162 S84DC-40-161 CM38
1967A-8765-170 S84DC-40-170 CM38
1967A-8765-187 S84DC-40-188 CM38
20028-96-198 SD96CC-3-199
20032-916-198 SD96CC-3-199
20037-72-156 SD72AC-1-156
20038-53-111 SD53CC-16-111
20043-63-120 SD63DB-14-120
20047-74-131 SD74CC-11-131
20051-63-96 SD63CC-11-96
20052-86-177 SD86CC-2-177
20054-83-126 SD83CC-27-126
20059-84-144 SD84CC-20-144
20059-84-178 SD84CC-20-178
20062-63-73 SD63CC-11-73
20062-63-96 SD63CC-11-96
20070-85-380 SD85DC-2-380
20074-916-456 SD96MC-5-456
20079-85-348 SD85CC-19-348
20085-73-156 SD73GF-2-156
20099-64-132 SD64CC-7-132
20099-64-152 SD64CC-7-152
20124-63-120 SD63DB-14-120
20125-52-119 SD52DC-8-119
20130-916-170 SD86CC-1-171
20134-62-114 SD62CB-11-114
20134-62-79 SD62CB-11-79

HYCO

20134-62-94 SD62CB-11-94
20147-814-135 SD84CC-21-135
20155-64-134 SD64CC-7-132
20157-53-104 SD53CC-25-106
20158-64-118 SD64CC-7-118
20171-62-82 SD62CC-20-82
20173-94-190 SD94CC-8-190
20179-85-348 SD85CC-19-348
20184-63-120 SD63DB-14-120
20189-63-132 SD64CC-7-132
20190-74-171 SD74DB-4-171
20191-63-108 SD63DB-6-108
20192-63-93 SD63DB-6-93
20214-74-144 SD74DB-6-144
20223-64-132 SD64CC-7-132
20223-64-152 SD64CC-7-152
20232-916-198 SD96CC-3-199
20234-63-118 SD63CB-14-118
20235-52-111 SD52CC-24-111
20237-62-114 SD62CB-11-114
20237-62-79 SD62CB-11-79
20237-62-94 SD62CB-11-94
20254-916-412 SD96MC-5-412
20254-916-456 SD96MC-5-456
20254-916-480 SD96MC-5-480
20258-915-160 SD95CC-3-160
20318-63-118 SD63CB-14-118
20335-63-124 SD63CC-24-124
20348-62-114 SD62CB-11-114
20348-62-79 SD62CB-11-79
20348-62-94 SD62CB-11-94
20433-934-176 SD94CC-7-176
20462-85-384 SD85MC-20-384
20528-74-163 SD74CC-14-163
20569-63-124 SD63CC-24-124
20577-63-167 SD63CB-15-167
20601-63-120 SD63DB-14-120
30000-83-138 S83DC-40-139
30000-84-140 S84DC-40-140
30000-84-148 S84DC-40-148
30000-84-156 S84DC-31-156
30000-84-164 S84DC-40-161
30000-84-168 S84DC-40-161
30000-84-170 S84DC-40-170
30000-84-175 S84DC-40-170
30000-84-180 S84DC-40-180
30000-84-188 S84DC-40-188
30000-84-190 S84DC-40-188
30000-85-160 S85DC-51-160
30000-85-165 S85DC-51-160
30000-85-170 S85DC-40-170
30000-85-190 S85DC-40-190
30000-85-195 S85DC-40-190
30000-85-200 S85DC-40-197
30000-85-220 S85DC-40A-220
30001-85-225 S85DC-40A-220
30001-85-235 S85DC-40-235
30001-85-250 S85DC-40-250
30001-85-265 S85DC-40A-265
30001-85-270 S85DC-40A-265
30009-85-195 S85DC-40-190 CM21
30009-85-220 S85DC-40A-220 CM21
30011-84-188 S84DC-40-188 CM9
30016-73-120 S73DC-40-120 CM4

HYCO

30016-73-130 S73DC-41-129 CM4
30016-73-132 S73DC-41-129 CM4
30016-73-140 S73DC-40-140 CM4
30016-73-141 S73DC-40-140 CM4
30016-73-150 S73DC-40-150 CM4
30016-73-151 S73DC-40-150 CM4
30016-74-120 S74DC-40A-120 CM4
30016-74-136 S74DC-40-135 CM4
30016-74-140 S74DC-40A-140 CM4
30016-74-156 S74DC-40-156 CM4
30016-74-164 S74DC-40-161 CM4
30016-74-166 S74DC-40-161 CM4
30016-74-168 S74DC-40-161 CM4
30017-63-120 S63DC-47-120 CM16
30021-63-84 S63DC-47-86 CM36
30021-63-104 S63DC-47-104 CM36
30021-63-108 S63DC-47-107 CM36
30021-63-120 S63DC-47-120 CM36
30021-63-126 S63DC-44-123 CM36
30021-63-132 S63DC-47-130 CM36
30023-85-170 S85DC-40-170
30025-935-190 S95DC-40-190 CM42
30025-935-220 S95DC-40-220 CM42
30025-935-235 S95DC-40-235 CM42
30025-935-240 S95DC-40-235 CM42
30025-935-250 S95DC-40-250 CM42
30025-935-255 S95DC-40-250 CM42
30025-935-270 S95DC-40-265 CM42
30038-915-220 S95DC-40-220 CM4
30038-915-235 S95DC-40-235 CM4
30039-53-63 S53DB-2-63
30041-84-156 S84DC-31-156
30041-84-190 S84DC-40-188
30042-85-235 S85DC-40-235
30042-85-250 S85DC-40-250
30043-85-200 S85DC-40-197 CM46
30043-85-220 S85DC-40A-220 CM46
30044-85-250 S85DC-40-250 CM46
30048-74-135 S74DC-41-135
30049-42-90T S42MB-3-90
30050-63-120T S63MB-9-120
30050-64-140T S64MB-4-140
30051-85-190 S85DC-40-190 CM53
30060-85-235T S85MC-48-235
30060-85-250T S85MC-48-250
30061-63-98 S63DC-47-104 CM36
30072-53-120T S53MB-3-120
30097-63-105 S63DC-47-107
30097-63-108 S63DC-47-107
30125-935-265 S95DC-40-265
30125-935-280 S95DC-40-280
30125-935-285 S95DC-40-280
30125-935-300 S95DC-40A-300
30129-63-108T S63MB-11-108
30129-63-144T S63MB-8-140
30129-64-140T S64MB-4-140
30143-73-120 S73DC-40-120 CM4
30143-73-130 S73DC-41-129 CM4
30143-73-132 S73DC-41-129 CM4
30143-73-140 S73DC-40-140 CM4
30143-73-141 S73DC-40-140 CM4
30143-73-150 S73DC-40-150 CM4
30143-73-151 S73DC-40-150 CM4
30143-74-120 S74DC-40A-120 CM4

Crossover and Application Data is for Reference Purpose Only. No Other Conditions are Expressed or Implied.
Note: In some applications, modifications may be required for proper cylinder installation.

Quick Reference Guide

HYCO

30143-74-136	S74DC-40-135 CM4
30143-74-140	S74DC-40A-140 CM4
30143-74-156	S74DC-40-156 CM4
30143-74-164	S74DC-40-161 CM4
30143-74-166	S74DC-40-161 CM4
30143-74-168	S74DC-40-161 CM4
30195-73-120	S73DC-40-120
30195-73-123	S73DC-40-120
30195-73-126	S73DC-40-124
30195-73-130	S73DC-41-129
30195-73-150	S73DC-40-150
30195-74-120	S74DC-40A-120
30195-74-136	S74DC-40-135
30195-74-140	S74DC-40A-140
30195-74-156	S74DC-40-156
30195-74-167	S74DC-40-161
30208-85-235	S85DC-40-235
30208-85-250	S85DC-40-250
30208-85-265	S85DC-40A-265
30238-63-138	S63DC-45-138
30238-63-162	S63DC-45-162
30251-63-120	S63DC-45-120
30251-63-126	S63DC-45-126
30251-63-138	S63DC-45-138
30251-63-162	S63DC-45-162
30252-53-99	S53DC-15-99
30252-53-105	S53DC-15-105
30252-53-120	S53DC-15-120
30252-53-123	S53DC-15-123
30278-915-190	S95DC-40-190 CM42
30278-915-220	S95DC-40-220 CM42
30278-915-235	S95DC-40-235 CM42
30278-915-250	S95DC-40-250 CM42
30283-84-140	S84DC-40-140
30283-84-148	S84DC-40-148
30283-84-156	S84DC-31-156
30283-84-164	S84DC-40-161
30283-84-168	S84DC-40-161
30283-84-170	S84DC-40-170
30283-84-175	S84DC-40-170
30283-84-180	S84DC-40-180
30283-84-188	S84DC-40-188
30283-84-190	S84DC-40-188
30283-85-160	S85DC-51-160
30283-85-165	S85DC-51-160
30283-85-170	S85DC-40-170
30283-85-190	S85DC-40-190
30283-85-195	S85DC-40-190
30283-85-200	S85DC-40-197
30283-85-220	S85DC-40A-220
30299-63-105	S63DC-47-107
30299-63-108	S63DC-47-107
30305-84-156	S84DC-31-156
30305-84-160	S84DC-31-156
30305-85-160	S85DC-51-160
30305-85-190	S85DC-40-190
30305-85-220	S85DC-40A-220
30320-915-280	S95DC-40-280
30320-915-300	S95DC-40A-300
30324-85-285	S85DC-40-285
30337-85-190T	S85MC-48-200
30337-85-200T	S85MC-48-200
30337-85-204T	S85MC-48-200
30337-85-220T	S85MC-48-220

HYCO

30337-85-225T	S85MC-48-220
30337-85-235T	S85MC-48-235
30338-915-190	S95DC-40-190
30338-915-220	S95DC-40-220
30338-915-235	S95DC-40-235
30338-915-250	S95DC-40-250
30347-63-77	S63DC-47-77
30347-63-84	S63DC-47-86
30347-63-90	S63DC-47-86
30347-63-96	S63DC-47-92
30347-63-104	S63DC-47-104
30347-63-108	S63DC-47-107
30347-63-111	S63DC-44-111
30347-63-120	S63DC-47-120
30347-63-126	S63DC-44-123
30347-63-129	S63DC-47-130
30347-63-130	S63DC-47-130
30347-63-132	S63DC-47-130
30347-63-136	S63DC-47-130
30347-63-140	S63DC-47-140
30353-73-108	S73DC-40-110
30353-73-120	S73DC-40-120
30353-73-123	S73DC-40-120
30353-73-126	S73DC-40-124
30353-73-130	S73DC-41-129
30353-73-150	S73DC-40-150
30353-74-120	S74DC-40A-120
30353-74-136	S74DC-40-135
30353-74-140	S74DC-40A-140
30353-74-156	S74DC-40-156
30353-74-167	S74DC-40-161
30357-63-84	S63DC-47-86 CM36
30357-63-104	S63DC-47-104 CM36
30357-63-108	S63DC-47-107 CM36
30357-63-120	S63DC-47-120 CM36
30357-63-126	S63DC-44-123 CM36
30357-63-132	S63DC-47-130 CM36
30372-63-81	S63DC-47-86
30372-63-108	S63DC-47-107
30372-63-130	S63DC-47-130
30384-53-99	S53DC-15-99
30384-53-105	S53DC-15-105
30384-53-120	S53DC-15-120
30384-53-123	S53DC-15-123
30384-53-126	S53DC-15-123
30387-74-135	S74DC-40-135
30387-74-140	S74DC-40A-140
30414-935-265	S95DC-40-265 CM4
30414-935-280	S95DC-40-280 CM4
30414-935-285	S95DC-40-280 CM4
30414-935-300	S95DC-40A-300
30426-73-140	S73DC-40-140
30426-73-150	S73DC-40-150
30426-74-120	S74DC-40A-120
30426-74-136	S74DC-40-135
30426-74-156	S74DC-40-156
30426-74-161	S74DC-40-161
30433-85-285	S85DC-40-285
30446-85-225	S85DC-40A-220
30446-85-235	S85DC-40-235
30446-85-250	S85DC-40-250
30446-85-265	S85DC-40A-265
30446-85-270	S85DC-40A-265
30470-64-132	S64DB-6-135

HYCO

30470-64-135	S64DB-6-135
30493-73-125	S73DC-40-124 CM38
30494-73-142	S73DC-40-140 CM38
30496-53-89	S53MB-5-90
30497-53-74	S53MB-5-74
30499-63-107	S63DC-47-107 CM38
30534-73-120	S73DC-40-120
30534-74-135	S74DC-40-135
30534-74-156	S74DC-40-156
30541-85-235	S85DC-40-235
30541-85-265	S85DC-40A-265
30576-42-90T	S42MB-3-90
30602-85-186	S85DC-40-190
30602-85-216	S85DC-40A-220
30607-85-235	S85MC-48-235
30607-85-250	S85MC-48-250
30607-85-265	S85MC-48-265
30607-85-280	S85MC-48-280
40026-85-220	SD85MC-16-220
40027-84-176	SD84MC-21-176
40030-84-406	SD84MC-23-406
40041-85-220	SD85MC-16-220
40045-934-188	SD94CC-8-190
40047-84-176	SD84MC-21-176
40050-84-406	SD84MC-23-406
50066-64-157	SD64DC-2-156
60025-935-220	S95DC-40-220 CM42
60251-63-120	S63DC-45-120
60251-63-126	S63DC-45-126
60251-63-138	S63DC-45-138
60251-63-162	S63DC-45-162
60726-63-102	SD63DC-70-101
60726-63-103	SD63DC-70-101
60727-63-82	SD63DC-70-81
60727-63-83	SD63DC-70-81
6260-BA	C3810
6262-BA	C3805
6312	C3808
6389-BA	C3863
6402	C3805
6404	C3842
70000-814-147	S84DC-40-148
70000-814-155	S84DC-31-156
70000-815-160	S85DC-51-160
70000-815-170	S85DC-40-170
70000-815-235	S85DC-40-235
70000-815-265	S85DC-40A-265
70016-73-120	S73DC-40-120 CM4
70016-74-120	S74DC-40A-120 CM4
70016-74-140	S74DC-40A-140 CM4
70016-74-156	S74DC-40-156 CM4
70021-63-120	S63DC-47-120 CM36
70022-815-235	S85DC-40-235 CM2
70025-935-250	S95DC-40-250 CM42
70048-74-135	S74DC-41-135
70049-42-90T	S42MB-3-90
70050-63-111T	S63MB-11-108
70050-63-120T	S63MB-9-120
70060-815-235T	S85MC-48-235
70060-815-250T	S85MC-48-250
70060-815-265T	S85MC-48-265
70072-53-120T	S53MB-3-120
70125-935-280	S95DC-40-280 CM4

Crossover and Application Data is for Reference Purpose Only. No Other Conditions are Expressed or Implied.

Note: In some applications, modifications may be required for proper cylinder installation.

Quick Reference Guide

HYCO

70129-63-108T	S63MB-11-108
70195-73-108	S73DC-40-110
70195-73-110	S73DC-40-110
70195-73-120	S73DC-40-120
70195-73-130	S73DC-41-129
70195-73-140	S73DC-40-140
70195-74-135	S74DC-40-135
70195-74-156	S74DC-40-156
70251-63-120	S63DC-45-120
70251-63-126	S63DC-45-126
70251-63-138	S63DC-45-138
70251-63-162	S63DC-45-162
70252-53-99	S53DC-15-99
70252-53-105	S53DC-15-105
70252-53-120	S53DC-15-120
70252-53-123	S53DC-15-123
70320-935-220	S95DC-40-220
70320-935-280	S95DC-40-280
70338-935-220	S95DC-40-220
70338-935-235	S95DC-40-235
70339-63-120	S63DC-45-120
70339-63-126	S63DC-45-126
70339-63-138	S63DC-45-138
70339-63-162	S63DC-45-162
70347-63-77	S63DC-47-77
70347-63-108	S63DC-47-107
70347-63-111	S63DC-44-111
70347-63-120	S63DC-47-120
70347-63-126	S63DC-44-123
70347-63-130	S63DC-47-130
70347-63-132	S63DC-47-130
70353-73-110	S73DC-40-110
70353-73-120	S73DC-40-120
70353-73-130	S73DC-41-129
70372-63-77	S63DC-47-77
70372-63-108	S63DC-47-107
70372-63-111	S63DC-44-111
70372-63-120	S63DC-47-120
70372-63-126	S63DC-44-123
70372-63-130	S63DC-47-130
70372-63-132	S63DC-47-130
70384-53-99	S53DC-15-99
70384-53-105	S53DC-15-105
70384-53-120	S53DC-15-120
70384-53-123	S53DC-15-123
70387-74-135	S74DC-40-135
70470-64-156	S64DB-6-156
70500-63-126	S63DC-47-126 CM38
70521-74-136	S74DC-41-135 CM8
70541-815-265	S85DC-40A-265
70576-42-90T	S42MB-3-90
70595-74-154T	S74MB-3-154
70595-74-172T	S74MB-3-172
70611-63-120	S63DC-45-120
70611-63-126	S63DC-45-126
70611-63-138	S63DC-45-138
70611-63-162	S63DC-45-162
70614-73-119	S73DC-40-120 CM38
70679-53-123	S53DC-15-123
70803-815-200T	S85MC-48-200
70803-815-240T	S85MC-48-235
70804-53-120T	S53MB-3-120
70805-64-156	S64DB-6-156
70807-63-120	S63DC-45-120

HYCO

70809-815-235T	S85MC-48-235
70809-815-250T	S85MC-48-250
70821-63-91.88	S63DC-47-92
70828-53-123	S53DC-11-126
7204-LM	C3808
8520-BA	C3863
8574-BA	C3863
9017-654-96	SD63CC-11-96
9018-654-73	SD63CC-11-73
9019-7654-131	SD74CC-11-131
9049-87654-348	SD85CC-19-348
9066A-825-7654-220	S85DC-40A-220 CM46
9066A-825-7654-250	S85DC-40-250 CM46
9066A-87654-202	S85DC-40-197 CM46
9066A-87654-220	S85DC-40A-220 CM46
9066A-87654-235	S85DC-40-235 CM46
9066A-87654-250	S85DC-40-250 CM46
9185-6543-140	S64MB-4-140
9280A-765-156	SD73GF-2-156
9306-543-111	SD53CC-16-111
9313-987654-198	SD96CC-3-199 9329-
987654-199	SD96CC-3-199
9331-76-156	SD72AC-1-156
9358-65-79	SD62CB-11-79
9358-65-94	SD62CB-11-94
9358-65-114	SD62CB-11-114
9406-8765-178	SD84CC-20-178
9408-8764-144	SD84CC-20-144
9420-7654-131	SD74CC-11-131
9438-654-96	SD63CC-11-96
9466-936-416	SD96MC-5-412
9466-936-456	SD96MC-5-456
9467-654-120	SD63DB-14-120
9467-654-132	SD63DB-7-132
9496-876543-177	SD86CC-2-177
9530-6543-132	SD64CC-7-132
9530-6543-152	SD64CC-7-152
9534-7654-144	SD74DB-6-144

JOHNSON

D3-38	S63DC-47-77 CM26
D3-42	S63DC-47-86 CM26
D3-48	S63DC-47-107 CM26
D3-50	S63DC-44-111 CM26
D3-52	S63DC-47-120 CM26
D3-55	S63DC-44-123 CM26
D3-60	S63DC-47-140 CM26
D3-63	S63DC-47-150 CM26
E3-50	S73DC-40-110 CM23
E3-52	S73DC-40-110 CM23
E3-55	S73DC-40-124 CM23
E3-60	S73DC-40-140 CM23
E3-63	S73DC-40-150 CM23
E4-45	S74DC-40A-120 CM23
E4-48	S74DC-40-135 CM23
F3-58	S84DC-40-140 CM66
F3-60	S83DC-40-139 CM66
F3-63	S83DC-51-150 CM66
F3-67	S84DC-40-170 CM66
F3-69	S83DC-40-160 CM66
F4-51	S84DC-40-148 CM22
F4-53	S84DC-31-156 CM22
F4-55	S84DC-40-161 CM22
F4-57	S84DC-40-170 CM22

JOHNSON

F4-60	S84DC-40-180 CM22
F4-62	S84DC-40-188 CM22
F5-55	S85DC-40-197 CM1
F5-59	S85DC-40A-220 CM1
G5-55	S95DC-40-190 CM22
G5-57	S95DC-40-190 CM22
G5-60	S95DC-40-220 CM22
G5-62	S95DC-40-220 CM22
G5-65	S95DC-40-235 CM22
G5-67	S95DC-40-250 CM22
G5-69	S95DC-40-250 CM22
G5-72	S95DC-40-265 CM22
G5-80	S95DC-40A-300 CM22
G5-85	S95DC-40A-320 CM22
FMD3-38	S63DC-47-77 CM26
FMD3-42	S63DC-47-86 CM26
FMD3-48	S63DC-47-107 CM26
FMD3-50	S63DC-44-111 CM26
FMD3-52	S63DC-47-120 CM26
FMD3-55	S63DC-44-123 CM26
FMD3-60	S63DC-47-140 CM26
FMD3-63	S63DC-47-150 CM26
FME3-50	S73DC-40-110 CM23
FME3-52	S73DC-40-110 CM23
FME3-55	S73DC-40-124 CM23
FME3-60	S73DC-40-140 CM23
FME3-63	S73DC-40-150 CM23
FME4-45	S74DC-40A-120 CM23
FME4-48	S74DC-40-135 CM23
FMF3-58	S84DC-40-140 CM66
FMF3-60	S83DC-40-139 CM66
FMF3-63	S83DC-51-150 CM66
FMF3-67	S84DC-40-170 CM66
FMF3-69	S83DC-40-160 CM66
FMF4-51	S84DC-40-148 CM22
FMF4-53	S84DC-31-156 CM22
FMF4-55	S84DC-40-161 CM22
FMF4-57	S84DC-40-170 CM22
FMF4-60	S84DC-40-180 CM22
FMF4-62	S84DC-40-188 CM22
FMF5-55	S85DC-40-197 CM1
FMF5-59	S85DC-40A-220 CM1
FMG5-55	S95DC-40-190 CM22
FMG5-57	S95DC-40-190 CM22
FMG5-60	S95DC-40-220 CM22
FMG5-62	S95DC-40-220 CM22
FMG5-65	S95DC-40-235 CM22
FMG5-67	S95DC-40-250 CM22
FMG5-69	S95DC-40-250 CM22
FMG5-72	S95DC-40-265 CM22
FMG5-80	S95DC-40A-300 CM22
FMG5-85	S95DC-40A-320 CM22

LESSARD / HYCO

093-1013-0	S43MM-1G-80
093-1014-0	S43MM-1G-90
093-1015-0	S43MM-1G-100
094-0008-0	S52MM-1G-82
094-1008-0	S52MM-1G-82
094-1018-0	S53MM-1G-100
094-1019-0	S53MM-1G-110
094-1020-0	S53MM-1G-120
095-1026-0	S63MM-1G-120
095-1027-0	S63MM-1G-130

Crossover and Application Data is for Reference Purpose Only. No Other Conditions are Expressed or Implied.

Note: In some applications, modifications may be required for proper cylinder installation.

Quick Reference Guide

LESSARD / HYCO

095-1038-0	S63MM-1G-140
096-1040-0	S73MM-1G-130
096-1040-1	S73MM-1G-130
096-1041-0	S73MM-1G-140
096-1041-1	S73MM-1G-140
096-1067-0	S63MM-1G-130
096-1068-0	S63MM-1G-140
096-2010-1	S74MM-2G-150
096-2010-2	S74MM-2G-150
096-2011-1	S74MM-2G-160
096-2011-2	S74MM-2G-160
097-2026-0	S74MM-2G-160
097-2027-0	S74MM-2G-170
098-2010-0	S84DC-40-148
098-2011-0	S84DC-40-180
098-2029-0	S74MM-4G-172
098-2030-0	S74MM-4G-182
098-3012-0	S85DC-40-190
098-3013-0	S85DC-40A-220
098-3014-0	S85DC-40-235
098-3015-0	S85DC-40-250
098-3016-0	S85DC-40A-265
098-3030-0	S85DC-40-235
098-3032-0	S85DC-40A-265
099-3005-1	S95DC-40A-300 CM42
099-3009-0	S95DC-40-250 CM42
099-3010-0	S95DC-40-190 CM42
099-3011-0	S95DC-40-235 CM42
099-3012-0	S95DC-40-265 CM42
099-3026-0	S95DC-40-250 CM42
193-A	S95DC-40-265 CM42
194-A	S95DC-40-235 CM42
195-A	S95DC-40-190 CM42
196-A	S95DC-40-250 CM42
500-A	S85DC-40-190
500-B	S85DC-40-190
501-A	S85DC-40A-220
501-B	S85DC-40A-220
502-A	S85DC-40-235
502-B	S85DC-40-235
503-A	S85DC-40-250
503-B	S85DC-40-250
504-A	S85DC-40A-265
504-B	S85DC-40A-265
519-A	S84DC-40-148
519-B	S84DC-40-148
520-A	S84DC-40-180
520-B	S84DC-40-180
SA80-3.5-3-TT-42.87-6.62	S43MM-1G-80
SA80-4.5-2-TT-49.25-6.62	S52MM-1G-82
SA90-3.5-3-TT-42.87-6.62	S43MM-1G-90
SA100-3.5-3-TT-42.87-6.62	S43MM-1G-100
SA100-4.5-3-TT-49.25-6.62	S53MM-1G-100
SA110-4.5-3-TT-49.25-6.62	S53MM-1G-110
SA120-4.5-3-TT-49.25-6.62	S53MM-1G-120
SA120-5.5-3-TT-54.62-6.62	S63MM-1G-120
SA130-5.5-3-TT-54.62-6.62	S63MM-1G-130
SA130-6.5-3-TT-54.87-7.62	S73MM-1G-130
SA130-6-3-TT-59.88-6.62	S63MM-1G-130
SA140-5.5-3-TT-57.75-6.62	S63MM-1G-140
SA140-6.5-3-TT-58.25-7.62	S73MM-1G-140
SA140-6-3-TT-59.88-6.62	S63MM-1G-140
SA148.5-8-4-BC-54	S84DC-40-148

LESSARD / HYCO

SA149-8-4-BC-54	S84DC-40-148
SA160-6.5-4-TT-54.87-7.62	S74MM-2G-160
SA160-7-4-TT-56.25-7.62	S74MM-2G-160
SA170-7-4-TT-56.25-7.62	S74MM-2G-170
SA170-8-4-TT-58.5-11.12	S74MM-4G-172
SA172.5-8-4-BC-60	S84DC-40-180
SA173-8-4-BC-60	S84DC-40-180
SA180-8-4-TT-58.5-11.12	S74MM-4G-182
SA186-8-5-BC-54	S85DC-40-190
SA190-8-5-BC-54	S85DC-40-190
SA196-912-5-BC-58	S95DC-40-190 CM42
SA216-8-5-BC-60	S85DC-40A-220
SA220-8-5-BC-60	S85DC-40A-220
SA235-8-5-BC-65	S85DC-40-235
SA235-912-5-BC-66	S95DC-40-235 CM42
SA250-8-5-BC-68	S85DC-40-250
SA250-912-5-BC-69	S95DC-40-250 CM42
SA265-8-5-BC-71	S85DC-40A-265
SA265-912-5-BC-72	S95DC-40-265 CM42
SA300-9.12-5-BC-79	S95DC-40A-300 CM42

MAILHOT

5000010	S74MM-4G-182
5000011	S85DC-40-190
5000012	S85DC-40A-220
5000021	S52MM-1G-82
5000026	S85DC-40-250
5000058	S95DC-40-250
5000078	S74MM-2G-150
5000081	S53MM-1G-90
5000085	S85DC-40-235
5000112	S43MM-1G-80
5000113	S43MM-1G-90
5000114	S43MM-1G-100
5000115	S53MM-1G-100
5000116	S53MM-1G-110
5000117	S53MM-1G-120
5000118	S63MM-1G-120
5000119	S63MM-1G-130
5000123	S73MM-1G-140
5000124	S74MM-2G-150
5000125	S74MM-2G-160
5000126	S74MM-2G-170
5000127	S73MM-1G-130
5000134	S95DC-40-235
5000174	S52MM-1G-90
5000175	S63MM-1G-110
5000176	S74MM-4G-172
5000277	S63MM-1G-140
5000280	S74MM-2G-180
9000012	S85DC-40-235
9000015	S85DC-40A-220
9000023	S85DC-40-250
9000025	S85DC-40-190
9000029	S95DC-40-250
9000030	S85DC-40-197
9000031	S84DC-40-188
9000034	S74DC-40-135
9000035	S73DC-40-110
9000036	S63DC-44-123
9000037	S63DC-44-111
9000038	S64DC-9-156
9000079	S95DC-40-235

MAILHOT

C111-6-3	S63DC-44-111
C111-7-3	S73DC-40-110
C123-6-3	S63DC-44-123
C135-7-4	S74DC-40-135
C156-6-4	S64DC-9-156
C162-7-4	S74DC-40-161
C183-8-4	S84DC-40-188
C190-8-5	S85DC-40-190
C200-8-5	S85DC-40-197
C220-8-5	S85DC-40A-220
C235-8-5	S85DC-40-235
C235-9.25-5	S95DC-40-235
C250-8-5	S85DC-40-250
C250-9.25-5	S95DC-40-250
M80-3.5-3	S43MM-1G-80
M82-4-2	S52MM-1G-82
M90-3.5-3	S43MM-1G-90
M90-4.5-2	S52MM-1G-90
M90-4-3	S53MM-1G-90
M100-3.5-3	S43MM-1G-100
M100-4.5-3	S53MM-1G-100
M110-4.5-3	S53MM-1G-110
M110-5.5-3	S63MM-1G-110
M120-4.5-3	S53MM-1G-120
M120-5.5-3	S63MM-1G-120
M130-5.5-3	S63MM-1G-130
M130-6.5-3	S73MM-1G-130
M140-5.5-3	S63MM-1G-140
M140-6.5-3	S73MM-1G-140
M150-6.5-4	S74MM-2G-150
M150-6-4	S74MM-2G-150
M160-6.5-4	S74MM-2G-160
M170-6.5-4	S74MM-2G-170
M172-7-4	S74MM-4G-172
M180-6.5-4	S74MM-2G-180
M182-7-4	S74MM-4G-182
M195-7-4	S74MM-4G-195
PC0601113HG0037	S63DC-44-111
PC0601233HG0036	S63DC-44-123
PC0601564HG0038	S64DC-9-156
PC0701113HG0035	S73DC-40-110
PC0701354HG0034	S74DC-40-135
PC0701624HG0033	S74DC-40-161
PC0801834HG0031	S84DC-40-188
PC0802005HG0030	S85DC-40-197
PC0802205HG0015	S85DC-40A-220
PC0802355HG0012	S85DC-40-235
PC0802505HG0023	S85DC-40-250
PC0802705HG0230	S85DC-40A-265
PC0922355HG0047	S95DC-40-235
PC0922505HG0029	S95DC-40-250
PM0350803VM0112	S43MM-1G-80
PM0350903VM0113	S43MM-1G-90
PM0351003VM0114	S43MM-1G-100
PM0400822VM0021	S52MM-1G-82
PM0400903VM0081	S53MM-1G-90
PM0450902VM0174	S52MM-1G-90
PM0451003VM0115	S53MM-1G-100
PM0451103VM0116	S53MM-1G-110
PM0451203VM0117	S53MM-1G-120
PM0551103VM0175	S63MM-1G-110
PM0551203VM0118	S63MM-1G-120

Crossover and Application Data is for Reference Purpose Only. No Other Conditions are Expressed or Implied.

Note: In some applications, modifications may be required for proper cylinder installation.

Quick Reference Guide

MAILHOT

PM0551303VM0119 ... S63MM-1G-130
 PM0551403VM0277 ... S63MM-1G-140
 PM0601504VM0078 ... S74MM-2G-150
 PM0651303VM0127 ... S73MM-1G-130
 PM0651403VM0123 ... S73MM-1G-140
 PM0651504VM0124 ... S74MM-2G-150
 PM0651604VM0125 ... S74MM-2G-160
 PM0651704VM0126 ... S74MM-2G-170
 PM0651804VM0280 ... S74MM-2G-180
 PM0701724VM0176 ... S74MM-4G-172
 PM0701824VM0010 ... S74MM-4G-182

MARION

3243C S32DB-1-43 CM72
 3250C S32DB-1-50 CM72
 4243C S42DB-5-43 CM72
 4250C S42DB-5-51 CM72
 4250T S42MB-6-50
 4375C S43DB-2-75 CM72
 5360C S53DB-13-60
 5374T S53MB-5-74
 5390C S53DB-13-90
 5390T S53MB-5-90
 A218630-119 S74DC-40A-120 CM26
 A218630-135 S74DC-40-135 CM26

MAXON

202104 C3831
 222740 C3694
 401216 S53DB-2-63
 401222 D60DD-4-69
 404614 C3694
 800000 C3831
 801374 C3831

NORDIC / NORDSEN

NTC-80-4-2 S52MM-1G-82
 NTC-100-4-3 S53MM-1G-100
 NTC-120-4-3 S53MM-1G-120
 NTC-134-6-3 S73MM-1G-140
 NTC-136-5 1/2-3 S63MM-1G-140
 NTC-137-5-3 S63MM-1G-140
 NTC-180-7-4 S74MM-4G-182

PERFECTION

A22275 S53DC-11-120
 A27123 S63DC-47-107
 A27134 S63DC-47-120
 A29651 S53DC-11-104
 A29652 S53DC-11-120
 A29732 S53DC-14-84
 A29741 S63DC-47-86
 A58627 S63DC-47-86
 A59327 S74DC-40-135
 A68577 S53DC-14-72 CM69
 A68827 S84DC-40-170
 A68829 S85DC-40-170
 A68832 S95DC-40-220
 A68835 S95DC-40-250
 A68841 S84DC-40-140
 A68859 S63DC-47-130
 A69064 S73DC-40-120
 A69066 S74DC-40A-120
 A69067 S74DC-40-135
 A69069 S85DC-40-170

PERFECTION

A69070 S85DC-40-190
 A69071 S85DC-40A-220
 A69072 S85DC-40-235
 A69073 S85DC-40-250
 A76479 S73DC-41-129
 A80314 S84DC-40-170
 A92097 S95DC-40-190
 A94464 S85DC-40-235
 A98278 S84DC-40-170
 A99108 S85DC-40-190
 A154781 S84DC-40-170
 A154875 S84DC-40-170
 A154877 S84DC-40-140
 A154879 S85DC-40-170

PRINCE

J1335 D60DB-7-72
 S1062 SD62CB-11-94
 S373 SD62CB-11-114
 S588 D70LN-2-80

R & S BODY

100586 S63DC-47-86 CM26
 100610 S73DC-40-124 CM23
 100628 S73DC-40-140 CM23
 100655 S84DC-40-188 CM22
 100659 S95DC-40A-300 CM22
 100661 S84DC-40-180 CM22
 100665 S84DC-40-170 CM22
 101055 S95DC-40-250 CM22

TESCO WILLIAMSEN

327-01-100 S42MB-3-90
 327-01-103 S53MB-3-120
 327-01-104 S63MB-9-120
 327-01-106 S63MB-8-140
 327-01-107 S74MB-3-154
 327-01-108 S74MB-3-172
 327-01-156 S63MB-8-140
 4290VI S42MB-3-90
 53120VI S53MB-3-120
 63120VI S63MB-9-120
 63140 S63MB-8-140
 63140VI S63MB-8-140
 74154VI S74MB-3-154
 74172VI S74MB-3-172
 WFMS-4290T S42MB-3-90
 WFMS-53120T S53MB-3-120
 WHP-53120VI S53MB-3-120
 WHP-63140VI S63MB-8-140
 WHP-74154VI S74MB-3-154
 WHP-74172VI S74MB-3-172

TRUXMORE

P1023 SD84CC-20-144
 P1027 SD84CC-20-178

Crossover and Application Data is for Reference Purpose Only. No Other Conditions are Expressed or Implied.

Note: In some applications, modifications may be required for proper cylinder installation.

Stock Piston Rod Cylinders

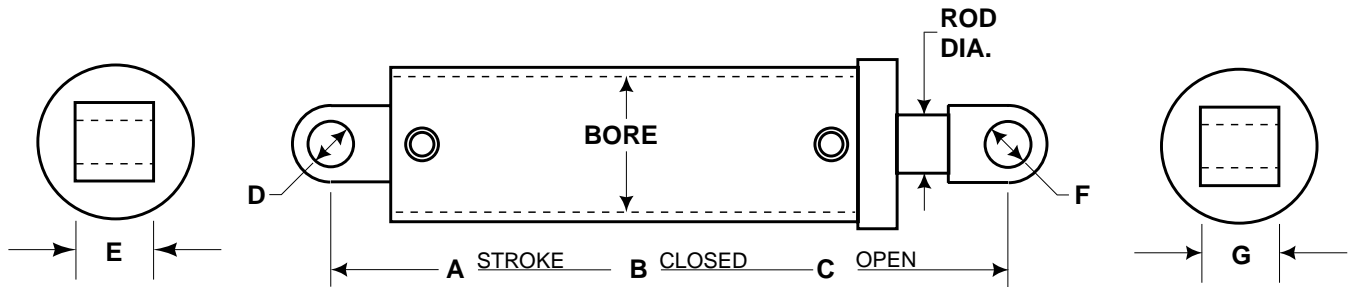

Cylinder Model	Cylinder Part Number	Bore Dia	Rod Dia	Stroke A	Closed B	Open C	Base D	Mount E	Plunger F	Mount G	Extend Port Size	Retract Port Size	Shpg. Wt.
C3603	C3603	3.00	1.50	11.00	23.12	34.12	1.00	2.00	1.00	2.00	#12	#12	115
C4438	C4438	3.00	1.50	25.25	34.25	59.50	1.00	1.00	1.13	2.00	#8	#8	55
C4439	C4439	3.00	1.50	25.25	34.25	59.50	1.00	0.75	1.13	2.00	#6	#6	55
B5162	B5162	3.00	1.75	28.19	38.00	66.19	1.00	1.00	1.00	1.50	#8	#8	75
C3602	C3602	3.00	1.50	30.50	43.88	74.38	1.00	1.50	1.00	1.50	#12	#12	70
B5347	B5347	3.00	2.50	31.25	38.75	70.00	1.00	1.50	1.00	0.88	"SA"	1/2	90
B3151	B3151	3.50	2.25	21.63	32.63	54.26	1.50	2.00	1.50	2.00	#12	#12	70
C3842	C3842	3.50	2.50	37.00	50.50	87.50	1.75	1.50	1.75	1.00	1/4	"S.A."	135
C3847	C3847	4.00	2.50	21.63	32.63	54.26	1.50	2.00	1.50	2.00	#12	#12	90
C3926	C3926	4.00	2.00	22.00	36.00	58.00	1.50	2.88	1.50	2.50	#10	#10	110
C3807	C3807	4.00	2.00	24.00	43.50	67.50	1.50	1.50	1.50	3.00	1/2	1/2	85
C3877	C3877	4.00	3.50	24.75	36.00	60.75	1.25	1.00	1.25	1.25	"SA"	1/2	95
C3831	C3831	4.00	2.50	29.75	39.00	68.75	1.50	4.50	1.38	2.50	3/4	3/4	95
C3863	C3863	4.00	2.50	35.31	51.44	86.75	1.25	2.75	1.25	2.50	3/8	3/8	130
C3850	C3850	4.50	2.00	26.50	40.62	67.12	1.50	2.00	1.50	2.50	#12	#12	105
B3152	B3152	4.50	2.00	26.94	40.63	67.57	1.50	2.00	1.50	2.00	#12	#12	105
C3933	C3933	4.50	2.50	41.50	59.38	100.88	2.00	2.00	2.00	2.88	#12	#12	183
C4622	C4622	4.50	2.50	41.50	57.00	98.50	2.00	2.00	THRD	2.25-12	#12	#12	170
C3843	C3843	5.00	3.00	20.00	33.00	53.00	2.00	2.00	2.00	2.00	#12	#12	130
C3805	C3805	5.00	3.00	27.00	39.00	66.00	1.75	3.00	1.75	3.00	3/4	3/4	137
C3872	C3872	5.00	2.50	36.00	49.25	85.25	2.00	1.88	2.63	1.88	#16	#16	185
C3813	C3813	5.00	2.50	43.75	57.62	101.37	2.00	2.00	THRD	2.25-12	3/4	3/4	175
C3694	C3694	5.00	2.50	51.00	64.50	115.50	1.75	2.50	1.75	2.50	1	1	225
C3563	C3563	5.50	4.00	54.13	75.00	129.13	1.25	1.25	1.25	2.00	#16	#16	305
C4793	C4793	5.50	4.00	63.00	81.00	144.00	2.00	3.00	2.00	3.00	#16	#16	260
D4088	D4088	5.50	4.00	63.00	81.12	144.12	2.00	6.50	2.00	3.88	#16	#16	245
C3810	C3810	6.00	2.50	34.00	51.00	85.00	1.75	3.00	1.75	3.00	1	1	205
C3814	C3814	6.00	2.50	34.00	48.50	82.50	1.75	3.00	THRD	2.50-12	1	1	176
D3855	D3855	6.00	4.00	63.00	75.00	138.00	2.00	7.00	2.00	3.88	1	1	300
D60DD-4-69	3771421090	6.00	3.75	69.00	84.31	153.31	3.50	7.00	2.75	5.00	1	1	390
D60DB-7-72	3771421147	6.00	4.50	72.00	90.00	162.00	2.50	7.00	2.50	4.38	#12	#12	400
D3838	D3838	6.00	3.00	76.00	89.62	165.62	3.50	7.25	3.50	3.50	#16	#16	356
D62DB-9-15	3771421118	6.25	2.00	15.00	26.69	41.69	2.00	7.00	0.75	2.00	3/4	3/4	121
D62DB-7-72	3771421102	6.25	4.75	72.00	90.00	162.00	2.50	7.00	2.50	4.38	#12	#12	410
D62LB-5-80	3771421180	6.25	4.75	80.00	98.75	178.75	2.50	6.53	2.50	4.69	3/4	3/4	320
D70LN-2-80	3773721025	7.00	3.00	80.00	92.50	172.50	SPL	LUGS	0.75	3.00	#12	#12	500
D70CC-8-108	3773721018	7.00	5.50	108.00	136.12	244.12	2.00	2.00	2.00	2.00	1	1	455
D70CC-8-131	3773721012	7.00	5.50	131.00	159.12	290.12	2.00	2.00	2.00	2.00	1	1	690
D72DB-7-15	3772521071	7.25	2.75	15.00	26.69	41.69	2.00	8.25	0.75	2.75	3/4	3/4	176
D72DB-7-25	3772521073	7.25	2.75	25.00	36.69	61.69	2.00	8.25	0.75	2.75	3/4	3/4	228
D72DB-7-25-1	3772521074	7.25	2.75	25.00	47.69	72.69	2.00	8.25	0.75	2.75	3/4	3/4	230
D72LB-9-80	3772521122	7.25	4.75	80.00	98.75	178.75	2.50	6.53	2.50	4.69	3/4	3/4	420
D84DB-7-25	3772921006	8.44	2.75	25.00	36.69	61.69	2.00	9.50	0.75	2.75	3/4	3/4	260
D84DB-7-25-1	3772921007	8.44	2.75	25.00	47.69	72.69	2.00	9.50	0.75	2.75	3/4	3/4	280

Stock Single-Acting Telescopic Cylinders With CC, DB, and DC Mounts

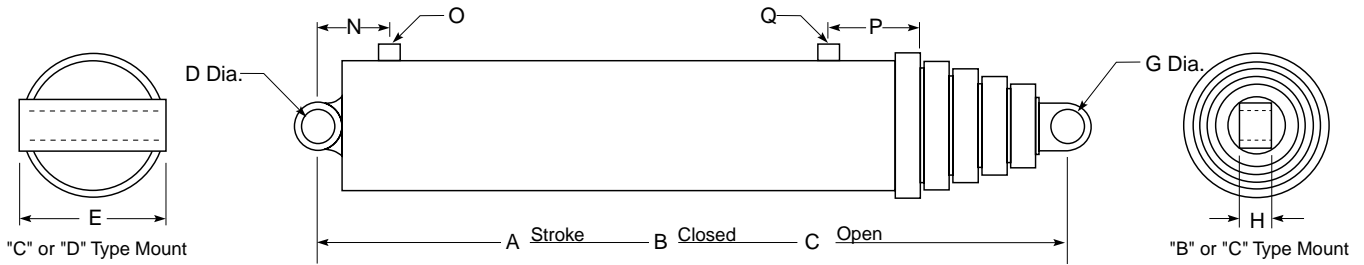

ENG. PN	10 DIGIT PN	A STROKE	B CLOSED	C OPEN	D	E	G	H	N	O	P	Q	GALS TO FILL	GALS TO EXTEND	WEIGHT LBS
S32DB-1-43	3780712001	42.62	29.69	72.31	2.00	4.00	1.25	1.69			19.00	1/2	0.7	0.8	40
S32DB-1-50	3780712002	50.00	33.38	83.38	2.00	4.00	1.25	1.69			19.00	1/2	0.8	1.0	50
S42CC-12-40	3771012035	40.00	32.44	72.44	1.50	2.00	1.50	2.00	14.00	1/2			1.1	1.5	85
S42DB-5-43	3781012004	43.62	30.19	73.81	2.00	5.00	1.50	2.62			19.00	1/2	1.2	1.6	70
S42DB-5-51	3781012001	51.00	33.88	84.88	2.00	5.00	1.50	2.62			19.00	1/2	1.3	1.9	80
S43DB-2-75	3781013002	74.04	33.88	107.92	2.00	5.00	1.25	1.69			19.00	1/2	1.2	2.1	85
S52CC-25-40	3771512043	40.00	32.44	72.44	1.50	2.00	1.50	2.00	14.00	1/2			1.8	2.5	110
S53DB-13-60	3781513005	60.00	30.00	90.00	2.00	6.00	1.50	2.63			19.00	1/2	1.7	3.0	120
S53DB-2-63	3771513013	63.00	34.12	97.12	3.63	6.25	1.50	2.69	4.75	3/4			1.5	3.1	140
S53DC-14-72	3771513084	72.00	37.19	109.19	2.00	7.00	1.63	1.50	19.50	3/4			1.8	3.5	155
S53DC-14-84	3771513085	84.00	41.19	125.19	2.00	7.00	1.63	1.50	19.50	3/4			2.0	4.2	165
S53DB-12-90	3781513001	90.00	39.75	129.75	2.00	6.00	1.62	2.63			19.00	1/2	2.2	4.5	160
S53DB-13-90	3781513002	90.00	39.75	129.75	2.00	6.00	1.50	2.63			19.00	1/2	2.2	4.5	160
S53DC-15-99	3771513091	99.00	46.50	145.50	2.00	7.75	1.75	1.50	24.81	#16			2.3	5.0	175
S53DB-8-103	3771513073	103.38	46.56	149.94	1.75	8.00	1.50	2.69			5.12	3/4	2.3	5.1	182
S53DC-11-104	3771513105	104.00	47.69	151.69	2.00	7.00	1.75	2.00			15.00	1	2.4	5.0	175
S53DC-15-105	3771513090	105.00	48.50	153.50	2.00	7.75	1.75	1.50	24.81	#16			2.4	5.2	205
S53DC-11-107	3771513069	107.56	48.38	155.94	2.00	7.00	1.75	2.00			15.00	1	2.4	5.3	200
S53DC-15-120	3771513089	120.00	52.50	172.50	2.00	7.75	1.75	1.50	24.81	#16			2.7	5.9	225
S53DC-11-120	3771513101	120.13	53.06	173.19	2.00	7.00	1.75	2.00			15.00	1	2.7	5.9	215
S53DC-15-123	3771513088	123.00	54.50	177.50	2.00	7.75	1.75	1.50	24.81	#16			2.8	6.1	230
S53DC-11-126	3771513070	126.63	54.56	181.19	2.00	7.00	1.75	2.00			15.00	1	2.8	6.2	220
S53DC-11-130	3771513103	129.88	56.31	183.19	2.00	7.00	1.75	2.00			15.00	1	2.9	6.4	230
S62CC-30-69	3771412059	69.00	49.25	118.25	1.50	1.50	1.50	1.50	4.50	1			4.3	6.5	220
S63DC-47-77	3771413179	77.00	39.00	116.00	2.00	7.00	2.00	2.00	20.81	1			2.8	6.1	230
S63DC-47-82	3771413133	82.50	43.56	126.06	2.00	7.00	2.00	2.00	20.81	1			3.2	6.4	250
S63DC-47-86	3771413180	86.75	40.88	127.63	2.00	7.00	2.00	2.00	20.81	1			3.1	6.9	250
S63DC-47-92	3771413181	92.00	45.00	137.00	2.00	7.00	2.00	2.00	20.81	1			3.4	7.3	260
S63DC-47-104	3771413187	103.94	47.00	150.94	2.00	7.00	2.00	2.00	20.81	1			3.6	8.1	260
S63DC-47-107	3771413185	107.56	48.38	155.94	2.00	7.00	2.00	2.00	20.81	1			3.7	8.4	260
S63DC-44-111	3771413125	111.00	49.94	160.94	2.00	7.00	2.00	2.00	3.81	1	24.00	1	3.8	8.7	260
S63DC-45-120	3771413127	120.00	53.50	173.50	2.38	8.00	2.19	1.50	24.91	#16			4.1	9.4	270

Note; Diameters D and G are for nominal pin size, for actual hole size refer to print.

Stock Single-Acting Telescopic Cylinders With CC, DB, and DC Mounts

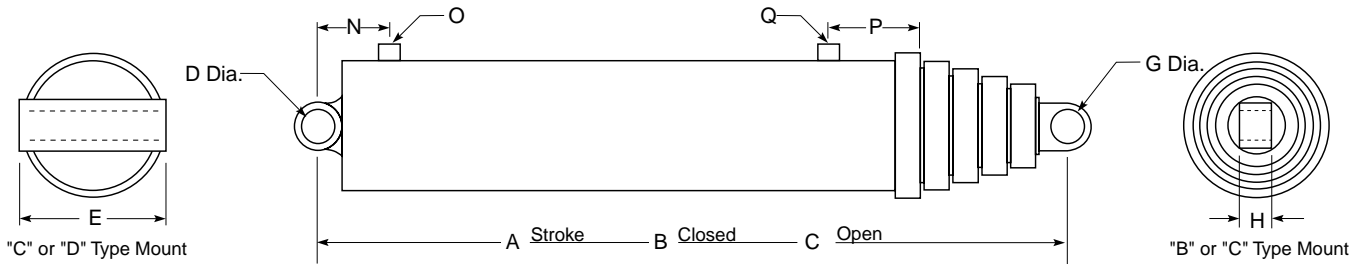

ENG. PN	10 DIGIT PN	A STROKE	B CLOSED	C OPEN	D	E	G	H	N	O	P	Q	GALS TO FILL	GALS TO EXTEND	WEIGHT LBS
S63DC-47-120	3771413183	120.06	52.62	172.68	2.00	7.00	2.00	2.00	20.81	1			4.1	9.4	270
S63DC-44-123	3771413126	123.00	54.94	177.94	2.00	7.00	2.00	2.00	3.81	1	24.00	1	4.2	9.6	270
S63DC-45-126	3771413128	126.00	55.50	181.50	2.38	8.00	2.19	1.50	24.91	#16			4.3	9.9	275
S63DC-47-126	3771413186	126.62	54.56	181.18	2.00	7.00	2.00	2.00	20.81	1			4.3	9.9	275
S63DC-47-130	3771413184	130.06	56.00	186.06	2.00	7.00	2.00	2.00	20.81	1			4.3	9.9	295
S63DC-45-138	3771413129	138.00	59.50	197.50	2.38	8.00	2.19	1.50	24.91	#16			4.6	11.1	300
S63DC-47-140	3771413149	140.25	59.81	200.06	2.00	7.00	2.00	2.00	20.81	1			4.7	11.1	295
S63DC-47-150	3771413182	150.00	63.00	213.00	2.00	7.00	2.00	2.00	20.81	1			5.0	11.9	310
S63DC-45-162	3771413130	162.00	67.50	229.50	2.38	8.00	2.19	1.50	24.91	#16			5.3	11.9	330
S64DB-6-135	3771414034	135.00	47.19	182.19	1.75	8.00	1.50	2.69			5.50	2, 3/4	3.4	8.1	260
S64DB-6-156	3771414035	156.00	53.19	209.19	1.75	8.00	1.50	2.69			5.50	2, 3/4	3.5	10.1	293
S64DC-9-156	3771414040	156.00	53.62	209.62	2.00	7.25	2.00	1.75	6.31	1			3.5	10.1	285
S64DC-7-157	3771414036	157.00	58.56	215.56	1.50	7.00	1.50	2.00	4.31	1			3.9	10.1	310
S73DC-40-110	3772513068	110.63	50.06	160.69	2.00	8.25	2.00	2.00	7.06	1	4.62	1	5.3	12.6	335
S73DC-40-120	3772513089	120.00	53.12	173.12	2.00	8.25	2.00	2.00	7.06	1	4.62	1	5.7	13.7	370
S73DC-40-124	3772513069	124.88	54.81	179.69	2.00	8.25	2.00	2.00	7.06	1	4.62	1	5.9	14.2	380
S73DC-41-129	3772513072	129.00	56.50	185.50	2.00	8.25	2.00	2.00	8.56	1	4.62	1	6.1	14.7	390
S73DC-40-140	3772513070	140.44	60.00	200.44	2.00	8.25	2.00	2.00	7.06	1	4.62	1	6.5	16.1	400
S73DC-40-150	3772513083	150.00	63.50	213.50	2.00	8.25	2.00	2.00	7.06	1	4.62	1	6.5	17.1	410
S74DC-40A-120	3772514056	120.00	44.12	164.12	2.00	8.25	2.00	2.00	7.06	1	4.62	1	4.1	11.5	335
S74DC-41-135	3772514052	135.00	48.31	183.31	2.00	8.25	1.63	1.50	18.31	3/4			4.5	13.1	370
S74DC-40-135	3772514047	135.00	48.44	183.44	2.00	8.25	2.00	2.00	7.06	1	4.62	1	4.5	13.1	370
S74DC-40A-140	3772514057	140.00	49.75	189.75	2.00	8.25	2.00	2.00	7.06	1	4.62	1	4.6	13.5	380
S74DC-40-156	3772514050	156.00	53.75	209.75	2.00	8.25	2.00	2.00	7.06	1	4.62	1	5.1	15.1	390
S74DC-40-161	3772514051	161.75	55.31	217.06	2.00	8.25	2.00	2.00	7.06	1	4.62	1	5.2	15.5	405
S74DC-40-180	3772514063	180.00	61.12	241.12	2.00	8.25	2.00	2.00	7.06	1	4.62	1	5.9	17.4	430
S83DC-26-134	3772913033	134.63	57.63	192.25	2.00	9.50	1.63	1.50	5.62	1			9.0	21.0	520
S83DC-40-139	3772913022	138.00	60.12	198.12	2.00	9.50	2.00	2.00	6.50	1	5.62	1	9.1	21.9	530
S83DC-51-150	3772913040	150.00	64.00	214.00	2.00	9.50	2.00	2.00	6.50	1	17.25	1	9.8	23.9	590
S83DC-40-160	3772913023	159.00	69.12	228.12	2.00	9.50	2.00	2.00	6.50	1	5.62	1	10.6	25.3	601

Note; Diameters D and G are for nominal pin size, for actual hole size refer to print.

Stock Single-Acting Telescopic Cylinders With CC, DB, and DC Mounts

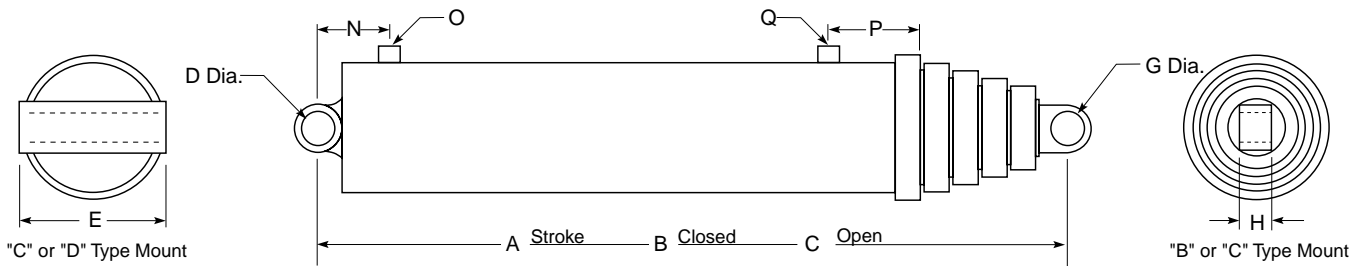

ENG. PN	10 DIGIT PN	A STROKE	B CLOSED	C OPEN	D	E	G	H	N	O	P	Q	GALS TO FILL	GALS TO EXTEND	WEIGHT LBS
S84DC-40-140	3772914051	140.00	49.75	189.75	2.00	9.50	2.00	2.00	6.50	1	5.62	1	6.5	19.2	485
S84DC-40-148	3772914052	147.50	51.50	199.25	2.00	9.50	2.00	2.00	6.50	1	5.62	1	6.7	20.3	530
S84DC-31-156	3772914048	156.00	53.75	209.75	2.00	9.50	2.00	2.00	5.56	1	5.62	1	7.1	21.5	550
S84DC-40-161	3772914014	160.00	55.75	215.75	2.00	9.50	2.00	2.00	6.50	1	5.62	1	7.4	21.9	565
S84DC-40-170	3772914050	170.00	57.25	227.25	2.00	9.50	2.00	2.00	6.50	1	5.62	1	7.6	23.3	575
S84DC-40-180	3772914053	180.00	59.75	239.75	2.00	9.50	2.00	2.00	6.50	1	5.62	1	8.0	24.7	580
S84DC-40-188	3772914057	188.00	61.75	249.75	2.00	9.50	2.00	2.00	6.50	1	5.62	1	8.3	25.8	585
S85DC-51-160	3772915096	160.00	48.00	208.00	2.00	9.50	2.00	2.00	6.56	1	15.50	1	5.5	18.5	560
S85DC-40-170	3772915077	170.00	49.88	219.88	2.00	9.50	2.00	2.00	6.50	1	5.62	1	5.8	20.1	570
S85DC-40-190	3772915022	189.00	54.62	243.62	2.00	9.50	2.00	2.00	6.50	1	5.62	1	6.4	22.3	580
S85DC-40-197	3772915021	196.13	55.25	251.38	2.00	9.50	2.00	2.00	6.50	1	5.62	1	6.5	22.8	590
S85DC-40A-220	3772915081	220.00	60.00	280.00	2.00	9.50	2.00	2.00	6.50	1	5.62	1	7.2	25.5	610
S85DC-40-235	3772915019	234.00	64.62	298.62	2.00	9.50	2.00	2.00	6.50	1	5.62	1	7.8	27.2	660
S85DC-40-250	3772915018	249.00	68.62	317.62	2.00	9.50	2.00	2.00	6.50	1	5.62	1	8.4	29.1	705
S85DC-40A-265	3772915080	265.00	71.00	336.00	2.00	9.50	2.00	2.00	6.50	1	5.62	1	8.7	31.6	776
S85DC-40-285	3772915078	285.00	78.50	363.50	2.00	9.50	2.00	2.00	6.50	1	5.62	1	9.8	34.1	800
S95DC-40-190	3773115015	190.00	56.00	246.00	2.00	10.88	2.00	2.00	6.50	1	5.75	1	6.4	22.4	835
S95DC-40-220	3773115011	218.00	62.44	280.44	2.00	10.88	2.00	2.00	6.50	1	5.75	1	9.7	36.2	855
S95DC-40-235	3773115010	233.00	65.44	298.44	2.00	10.88	2.00	2.00	6.50	1	5.75	1	10.2	38.7	880
S95DC-40-250	3773115009	248.00	68.44	316.44	2.00	10.88	2.00	2.00	6.50	1	5.75	1	10.8	41.3	1100
S95DC-40-265	3773115013	265.00	72.62	337.62	2.00	10.88	2.00	2.00	6.50	1	5.75	1	11.6	44.6	1160
S95DC-40-280	3773115016	280.00	78.62	358.62	2.00	10.88	2.00	2.00	6.50	1	5.75	1	12.8	47.6	1200
S95DC-40A-300	3773115022	300.00	79.00	379.00	2.00	10.88	2.00	2.00	6.50	1	5.75	1	13.5	50.2	1255
S95DC-40A-320	3773115023	320.00	83.00	403.00	2.00	10.88	2.00	2.00	6.50	1	5.75	1	13.9	54.1	1300
S95DC-40A-340	3773115040	340.00	87.00	427.00	2.00	10.88	2.00	2.00	6.50	1	5.75	1	14.5	59.9	1350
S96DC-1-285	3773116001	285.00	70.63	355.63	2.00	10.88	2.00	2.00	6.50	1	5.75	1	10.3	41.8	1045

Note; Diameters D and G are for nominal pin size, for actual hole size refer to print.

Stock Single-Acting Telescopic Cylinders With MB and MC Mounts

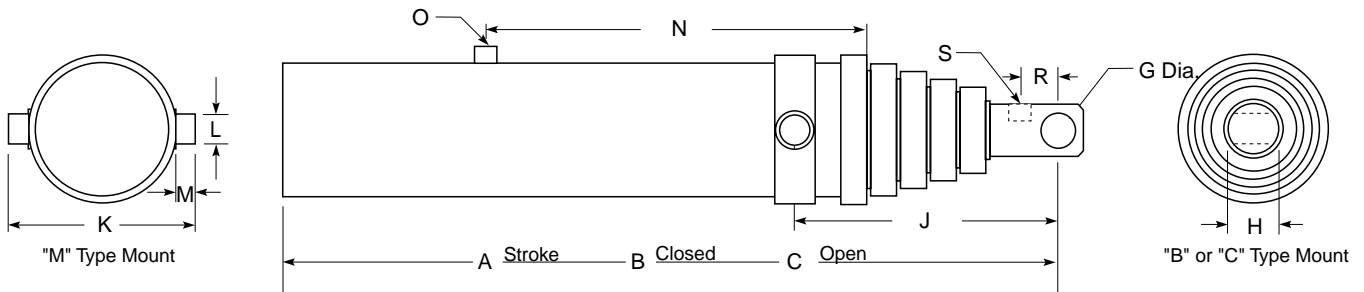

ENG. PN	10 DIGIT PN	A STROKE	B CLOSED	C OPEN	G	H	J	K	L	M	N	O	R	S	GALS TO FILL	GALS TO EXTEND	WEIGHT LBS
S42MB-6-50	3781012003	50.00	32.31	82.31	1.38	2.62	8.50	8.75	1.75	0.88	19.00	1/2			1.3	1.8	80
S42MB-7-50	3781012005	50.00	32.31	82.31	1.38	2.62	7.50	8.75	1.75	0.88	19.00	1/2			1.3	1.8	80
S42MB-5-60	3781012002	60.00	37.31	97.31	1.25	2.62	7.50	9.25	1.75	1.50	19.00	1/2			1.4	1.9	85
S42MB-3-90	3771012040	90.00	55.81	145.81	1.25	2.62	7.50	8.00	1.25	1.13			1.25	1/2	1.4	1.9	155
S43MB-1-75	3781013003	74.04	32.50	106.54	1.25	1.69	8.50	8.75	1.75	0.88	19.00	1/2			1.2	2.1	82
S43MB-2-75	3781013004	74.04	32.50	106.54	1.25	1.88	7.50	8.75	1.75	0.88	19.00	1/2			1.2	2.1	82
S53MB-5-74	3781513003	74.00	32.88	106.88	1.38	2.62	8.50	8.75	1.75	0.88	19.00	1/2			1.9	3.7	125
S53MB-5-90	3781513004	90.00	38.38	128.38	1.38	2.62	8.50	8.75	1.75	0.88	19.00	1/2			2.2	4.5	150
S53MB-3-120	3771513086	120.00	53.50	173.50	1.50	2.62	14.37	12.38	1.75	1.69			2.00	1	2.7	5.9	225
S63MB-11-108	3771413167	108.00	50.12	158.12	1.50	3.00	14.37	12.38	1.75	1.69			2.00	1	3.8	8.4	260
S63MB-9-120	3771413140	120.00	54.88	174.88	1.50	3.62	14.37	12.38	1.75	1.69			2.00	1	4.2	9.4	270
S63MB-8-140	3771413124	140.25	61.62	201.87	1.50	3.62	14.37	12.38	1.75	1.69			2.00	1	4.8	11.2	280
S64MB-4-140	3771414039	140.00	50.38	190.38	1.50	2.62	14.37	12.38	1.75	1.69			2.00	1	3.3	9.1	290
S74MB-3-154	3772514058	154.00	55.62	209.62	1.50	3.62	14.37	12.25	1.75	1.62			2.00	1	5.2	15.1	412
S74MB-3-172	3772514062	172.00	58.34	230.34	1.50	3.62	14.37	12.25	1.75	1.62			2.00	1	5.6	16.6	436
S85MC-48-200	3772915121	199.00	55.00	254.00	2.00	3.00	15.50	14.00	2.25	1.25			2.00	1	6.4	23.5	620
S85MC-48-220	3772915122	219.00	59.00	278.00	2.00	3.00	15.50	14.00	2.25	1.25			2.00	1	7.1	26.1	640
S85MC-48-235	3772915123	234.00	65.00	299.00	2.00	3.00	15.50	14.00	2.25	1.25			2.00	1	7.8	27.2	670
S85MC-48-250	3772915120	249.00	67.00	316.00	2.00	3.00	15.50	14.00	2.25	1.25			2.00	1	8.4	29.1	720
S85MC-48-265	3772915119	265.00	71.00	336.00	2.00	3.00	15.50	14.00	2.25	1.25			2.00	1	8.7	31.6	780
S85MC-48-280	3772915118	280.00	78.87	358.87	2.00	3.00	15.50	14.00	2.25	1.25			2.00	1	9.8	34.1	800

Note; Diameter G is for nominal pin size, for actual hole size refer to print.

Stock Single-Acting Telescopic Cylinders, CT Series

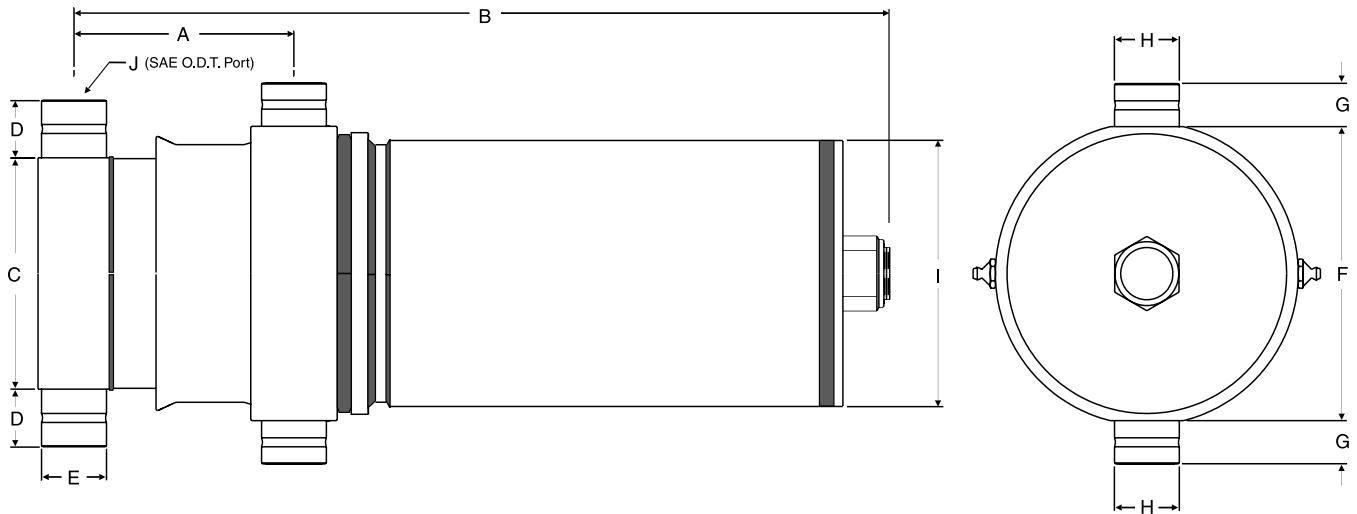

ENG. PN	10 DIGIT PN	STROKE	A	B	C	D	E	F	G	H	I	J	WEIGHT LBS	GALS TO EXTEND
S43MM-1G-80	3771013007	80	5.50	38.13	4.75	2.00	1.88	6.75	1.25	1.88	5.75	#10	145	4.6
S43MM-1G-90	3771013008	90	5.50	45.38	4.75	2.00	1.88	6.75	1.25	1.88	5.75	#10	150	5.3
S43MM-1G-100	3771013009	100	5.50	45.38	4.75	2.00	1.88	6.75	1.25	1.88	5.75	#10	150	5.7
S52MM-1G-82	3771512062	82	5.69	53.88	5.75	2.00	1.88	8.00	1.25	1.88	6.75	#12	220	6.7
S52MM-1G-90	3771512063	90	5.50	55.88	5.75	2.00	1.88	8.00	1.25	1.88	6.75	#12	220	7.3
S53MM-1G-90	3771513134	90	5.25	53.38	5.75	2.00	1.88	8.00	1.25	1.88	6.75	#12	320	6.6
S53MM-1G-100	3771513131	100	5.50	55.06	5.75	2.00	1.88	8.00	1.25	1.88	6.75	#12	320	7.7
S53MM-1G-110	3771513132	110	5.50	55.06	5.75	2.00	1.88	8.00	1.25	1.88	6.75	#12	320	8.0
S53MM-1G-120	3771513133	120	5.50	55.06	5.75	2.00	1.88	8.00	1.25	1.88	6.75	#12	320	8.2
S63MM-1G-110	3771413209	110	5.88	57.75	7.00	2.00	1.88	9.00	1.25	1.88	8.00	#12	450	12.4
S63MM-1G-120	3771413210	120	6.38	57.25	7.00	2.00	1.88	9.00	1.25	1.88	8.00	#12	450	12.8
S63MM-1G-130	3771413211	130	6.38	57.25	7.00	2.00	1.88	9.00	1.25	1.88	8.00	#12	450	13.3
S63MM-1G-140	3771413212	140	6.38	60.25	7.00	2.00	1.88	9.00	1.25	1.88	8.00	#12	460	14.1
S73MM-1G-130	3772513110	130	7.63	62.88	8.00	2.00	2.25	10.19	1.50	2.25	9.17	#16	575	19.1
S73MM-1G-140	3772513111	140	7.63	62.88	8.00	2.00	2.25	10.19	1.50	2.25	9.17	#16	575	19.9
S74MM-2G-150	3772514086	150	7.63	62.88	8.00	2.00	2.25	10.19	1.50	2.25	9.17	#16	660	19.9
S74MM-2G-160	3772514085	160	7.63	62.88	8.00	2.00	2.25	10.19	1.50	2.25	9.17	#16	660	20.3
S74MM-2G-170	3772514087	170	7.63	62.88	8.00	2.00	2.25	10.19	1.50	2.25	9.17	#16	660	20.9
S74MM-2G-180	3772514091	180	7.63	62.88	8.00	2.00	2.25	10.19	1.50	2.25	9.17	#16	660	21.4
S74MM-4G-172	3772514088	172	9.63	65.13	9.00	2.00	2.25	11.19	1.25	2.25	9.17	#16	680	22.8
S74MM-4G-182	3772514089	182	9.63	65.13	9.00	2.00	2.25	11.19	1.25	2.25	9.17	#16	680	23.3
S74MM-4G-195	3772514090	195	9.63	65.13	9.00	2.00	2.25	11.19	1.25	2.25	9.17	#16	680	23.9

OUR DESIGN ADVANTAGES INCLUDE:

- * Longer sleeve overlap for improved stability.
- * Threaded steel stop rings for easier servicing and more reliable stopping action.
- * Replaceable, hardened bushings on base trunnion mounts.
- * Floating trunnion on a true spherical bearing which guarantees self-alignment while maintaining full contact with surface when extending.
- * Wave springs and chevron packing for self-compensating seals.
- * Hytrel rod wipers that resist higher temperatures without extrusion.
- * Snap-on, glass-filled bearings that absorb contaminants without damaging cylinder walls.
- * Internal packing nuts give added support to the tube exterior while making service procedures easier.

Stock Double-Acting Telescopic Cylinders Non-Trunnion Mount Designs

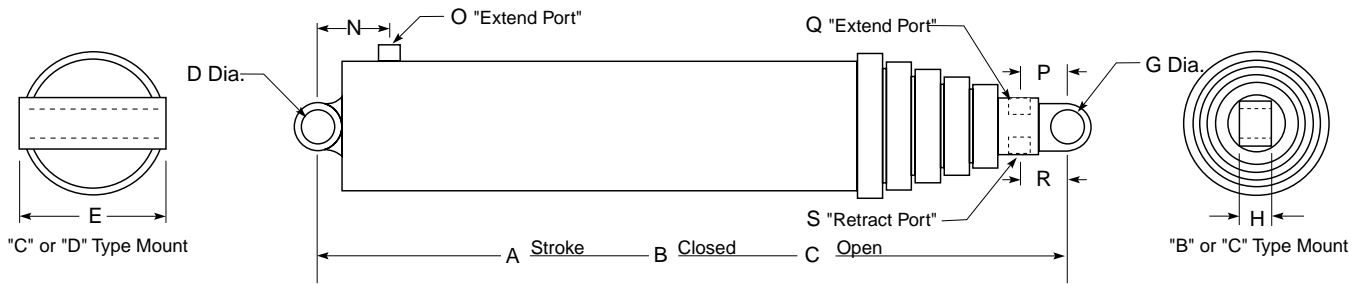

ENG. PN	10 DIGIT PN	A STROKE	B CLOSED	C OPEN	D	E	G	H	N	O	P	Q	R	S	GALS TO FILL	GALS TO EXTEND	WEIGHT LBS
SD42CC-19-111	3771032025	111.75	75.50	187.25	2.00	2.00	1.50	2.00			3.43	#16	3.43	#8	2.9	5.4	220
SD52CC-24-111	3771532049	111.75	75.50	187.25	2.00	2.00	2.00	2.00			3.12	#20	3.12	#12	4.6	8.7	275
SD53CC-25-106	3771533051	106.00	50.00	156.00	1.50	2.00	1.50	2.25			2.38	#12	2.38	#10	2.7	6.8	225
SD53CC-16-111	3771533038	111.00	56.75	167.50	3.00	2.00	1.50	2.00	2.88	3/4			2.62	3/4	2.7	7.1	235
SD53CC-26-155	3771533052	155.75	75.50	231.25	2.00	2.00	1.50	2.00			3.18	#16	3.18	#8	3.9	9.9	325
SD53CD-2-182	3771533067	182.00	81.00	263.00	2.00	3.88	2.00	6.50			3.06	#16	3.06	#8	4.2	11.6	345
SD53CC-31-182	3771533065	182.00	81.25	263.25	2.00	3.00	2.00	3.00			3.56	#16	3.56	#12	4.2	11.6	345
SD62DB-2-78	3771432059	78.00	56.62	134.62	2.50	7.50	2.50	4.63	3.31	1	2.75	1	2.75	1	4.9	8.9	300
SD62CB-11-79	3771432071	79.00	58.50	137.50	2.50	3.00	2.50	4.69			O/E	#12	O/E	#12	6.1	9.0	330
SD62CC-20-82	3771432054	82.00	56.50	138.50	3.00	2.25	3.00	2.25	4.13	3/4			3.00	3/4	5.1	9.2	300
SD62CB-11-94	3771432069	94.00	66.00	160.00	2.50	3.00	2.50	4.69			O/E	#12	O/E	#12	5.8	10.6	350
SD62CB-11-114	3771432070	114.00	76.00	190.00	2.50	3.00	2.50	4.69			O/E	#12	O/E	#12	6.8	12.9	375
SD63CC-11-73	3771433025	73.00	48.00	121.00	1.25	1.50	1.25	1.50			3.62	1	3.62	3/4	3.4	7.1	240
SD63DC-70-81	3771433208	82.84	62.50	145.34	2.00	7.25	2.00	2.48			3.92	#16	3.96	#16	4.9	7.8	260
SD63DB-6-93	3771433073	93.00	50.75	143.75	1.75	7.13	1.75	3.69			2.25	3/4	2.25	3/4	3.9	8.9	268
SD63CC-11-96	3771433044	96.00	52.44	148.44	1.25	1.50	1.25	1.50			3.62	1	3.62	3/4	3.9	9.2	275
SD63DC-70-101	3771433207	101.75	62.50	164.25	2.00	7.25	2.00	2.48			3.92	#16	3.96	#16	4.9	9.7	260
SD63DB-6-108	3771433048	108.00	50.75	158.75	1.75	7.13	1.75	3.69			2.25	3/4	2.25	3/4	3.9	10.4	290
SD63CB-14-118	3771433105	118.00	58.50	176.50	2.50	3.00	2.50	3.69			2.25	#16	2.25	#12	4.3	11.4	310
SD63DB-10-120	3771433067	120.00	58.50	178.50	3.00	7.25	2.50	3.69	3.56	1	2.50	1	2.50	1	4.4	11.5	315
SD63DB-14-120	3771433104	120.00	60.00	180.00	2.00	8.25	2.00	3.69	3.12	1	2.25	1	2.25	1	4.4	11.5	315
SD63CC-24-124	3771433060	124.50	76.88	201.38	2.00	2.00	2.00	2.00			5.94	1	5.94	1/2	4.8	11.9	330
SD63DB-7-132	3771433046	132.00	62.38	194.38	1.75	7.13	1.75	3.69			2.25	3/4	2.25	3/4	4.7	12.7	330
SD63CB-15-132	3771433117	132.75	85.25	218.00	2.00	4.00	2.00	3.94			4.62	#16	3.25	#12	6.6	12.8	455
SD63DB-11-152	3771433068	152.25	69.00	221.25	2.50	7.50	2.50	3.69	3.31	1	2.50	1	2.50	1	5.3	14.6	450
SD63CB-15-167	3771433116	167.00	85.25	252.25	2.00	4.00	2.00	3.94			4.62	#16	3.25	#12	6.6	16.1	455
SD64CC-7-118	3771434037	118.00	50.00	168.00	1.50	2.00	1.50	2.25			2.38	#12	2.38	#10	3.5	9.6	265
SD64CC-7-132	3771434035	132.19	50.00	182.19	1.50	2.00	1.50	2.25			2.38	#12	2.38	#10	3.5	10.7	265
SD64CC-7-152	3771434036	152.00	55.00	207.00	1.50	2.00	1.50	2.25			2.38	#12	2.38	#10	3.9	12.5	310
SD64DC-2-156	3771434040	156.64	62.50	219.14	2.00	7.25	2.00	2.48			2.00	#16	2.00	#16	7.2	12.6	340
SD72AC-1-156	3772532018	156.00	96.00	252.00	N/A	N/A	2.00	2.00			3.00	1 1/4	3.00	1	10.5	24.4	650

Note; Diameters D and G are for nominal pin size, for actual hole size refer to print.

Stock Double-Acting Telescopic Cylinders Non-Trunnion Mount Designs

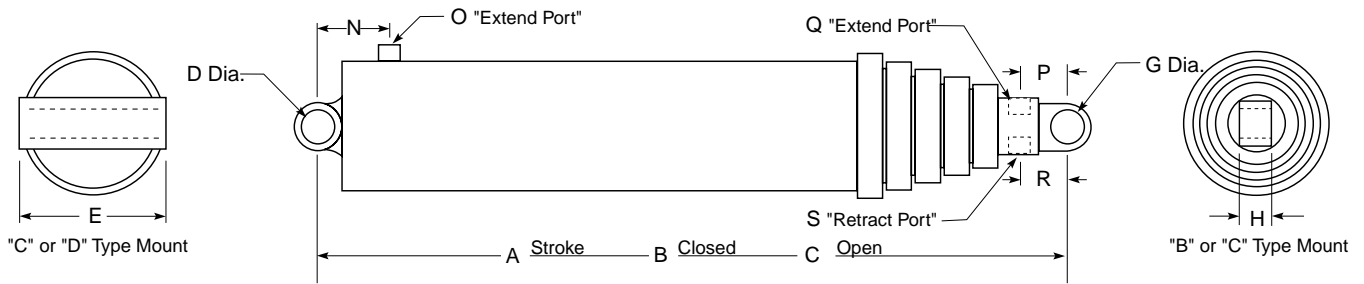

ENG. PN	10 DIGIT PN	A STROKE	B CLOSED	C OPEN	D	E	G	H	N	O	P	Q	R	S	GALS TO FILL	GALS TO EXTEND	WEIGHT LBS
SD73DB-6-115	3772533050	115.88	56.38	172.26	3.00	8.25	3.00	4.69			2.00	1	2.00	3/4	6.1	15.6	395
SD73CC-25-120	3772533045	120.00	64.75	184.75	2.00	2.00	2.00	2.00			3.62	3/4	3.62	1/2	6.7	16.3	430
SD73GF-2-156	3772533024	156.00	73.62	229.62	FLG	MNT	DRL	TPD			1.25	1	1.25	3/4	8.4	21.1	520
SD74CC-11-131	3772534032	131.50	53.38	184.88	1.25	1.50	1.25	1.50			3.88	3/4	3.88	3/4	4.7	15.3	375
SD74DB-6-144	3772534037	144.00	56.50	200.50	3.00	8.25	2.00	3.63			2.25	1	2.25	3/4	5.2	16.8	445
SD74CC-14-163	3772534045	163.00	77.00	240.00	2.00	2.00	2.00	2.00			6.00	1	6.00	1/2	6.1	19.1	525
SD74DB-4-171	3772534031	171.00	62.38	233.38	1.75	7.00	1.75	3.63			2.25	3/4	2.25	3/4	5.6	20.0	485
SD75OO-2-113	3772535005	113.50	39.50	153.00	BALL	3" DIA	BALL	3" DIA	4.38	#12			2.12	#8	2.8	11.4	280
SD83CB-16-117	3772933016	117.00	59.75	176.75	3.19	1.50	1.50	3.63			3.38	1/2	1.62	1/2	9.0	21.6	520
SD83CC-24-131	3773033043	131.50	60.00	191.50	1.75	2.00	1.75	2.00	4.50	1/2			2.00	1/2	9.4	24.2	575
SD83CC-24-132	3773033042	132.00	63.00	195.00	1.75	2.00	1.75	2.00	4.50	1/2			2.00	1/2	9.8	24.4	575
SD83CB-11-147	3773033030	147.00	68.00	215.00	2.00	2.00	2.00	3.63			3.12	1/2	1.38	1/2	10.9	27.2	650
SD83CC-24-156	3772933015	156.00	73.00	229.00	1.75	2.00	1.75	2.00	4.50	1/2			2.00	1/2	11.4	28.8	645
SD83GF-2-156	3772933018	156.00	73.62	229.62	FLG	MNT	DRL	TPD			1.75	1 1/4	1.75	1	11.5	28.8	650
SD83CC-22-176	3773303038	176.81	82.00	258.81	1.75	2.50	1.75	2.00	O/B	3/8	3.75	1/2	2.00	3/8	12.6	32.5	815
SD83GF-2-177	3772933017	177.00	85.00	262.00	FLG	MNT	DRL	TPD			1.75	1 1/4	1.75	1	13.3	32.7	680
SD83LF-5-177	3773033027	177.13	77.50	254.63	2.00	4.00	PLT	MNT	4.00	1/2	O/E	3/4	O/E	3/8	12.3	32.7	765
SD84CC-21-135	3772934037	135.25	61.00	196.25	2.00	2.00	2.00	2.00			6.62	#20	6.62	#16	7.1	21.9	560
SD84CC-20-144	3772934036	144.75	65.00	209.75	1.75	2.00	1.75	2.00			3.43	#24	3.43	#12	8.3	23.4	625
SD84CC-20-178	3772934035	178.38	69.25	247.63	1.75	2.00	1.75	2.00			3.43	#24	3.43	#12	8.8	28.9	665
SD85CC-15-125	3772935003	125.00	49.75	174.75	2.00	2.50	2.00	2.50	6.75	#12	2.50	#12	2.25	2, #8	5.4	17.8	505
SD85DB-5-220	3773035034	220.00	65.25	285.25	3.00	9.50	2.50	3.69	4.12	1			2.25	1	9.9	31.2	609
SD85CC-19-348	3772935026	348.00	99.88	447.88	2.00	2.00	2.00	2.00			4.25	1 1/4	4.00	1	10.7	49.4	885
SD85CC-19-378	3772935027	378.00	104.75	482.75	2.00	2.00	2.00	2.00			4.25	1 1/4	4.00	1	11.4	53.6	1015
SD85DC-2-380	3772935014	380.00	101.19	481.19	2.00	9.50	2.00	2.00			4.12	1 1/4	4.12	1	12.1	53.9	1100
SD86OO-1-146	3772936002	146.50	43.31	189.91	BALL	3" DIA	BALL	3" DIA	4.38	#12			2.12	#8	3.9	18.2	400
SD86CC-1-171	3772936001	171.00	49.75	220.75	2.00	2.50	2.00	2.50	6.75	#12	2.50	#12	2.25	2, #8	5.1	21.3	513
SD86CC-2-177	3772936004	177.00	53.38	230.38	1.25	1.50	1.25	1.50			3.43	3/4	3.43	3/4	5.2	22.0	525
SD93LF-1-177	3773133005	177.00	77.50	254.50	2.00	4.00	PLT	MNT	4.00	3/4			O/E	3/4	15.9	44.5	1060
SD94CC-7-176	3778634004	176.13	69.13	245.26	2.50	3.00	2.50	3.00			4.25	#20	4.25	#12	11.3	39.00	930
SD94CC-8-190	3773134005	190.00	71.00	261.00	2.25	2.25	2.00	2.00			4.38	#20	4.38	#16	11.7	42.1	930
SD94CC-9-190	3773134006	190.00	74.00	264.00	2.25	2.25	2.00	2.00			4.38	#20	4.38	#16	12.3	42.1	950
SD95CC-3-160	3773135018	160.00	61.00	221.00	2.00	2.00	2.00	2.00			6.62	#20	6.62	#16	8.5	31.5	810
SD96CC-3-199	3773136009	199.69	57.56	257.25	2.00	2.00	2.00	2.00			4.12	1 1/4	4.12	1	7.3	34.6	795

Note: SD83CB-11- and SD83CB-16- are Skip-A-Sleeve Designs, with Plunger and all Sleeves Double-Acting
 Note: SD83CC-22-, SD83CC-24-, SD83LF-5-, and SD93LF-1- are Skip-A-Sleeve Designs, only the Plunger is Double-Acting, The Sleeves are Single-Acting

Note: Diameters D and G are for nominal pin size, for actual hole size refer to print.

Stock Double-Acting Telescopic Cylinders Trunnion Mount Designs

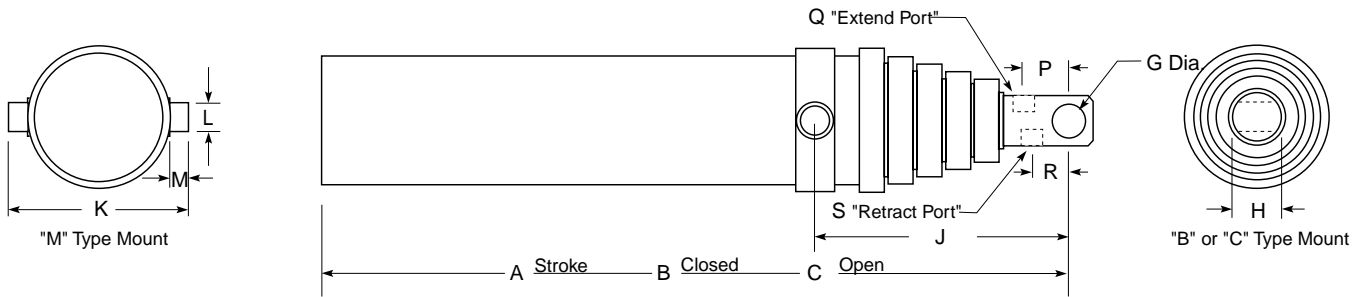

ENG. PN	10 DIGIT PN	A STROKE	B CLOSED	C OPEN	G	H	J	K	L	M	P	Q	R	S	GALS TO FILL	GALS TO EXTEND	WEIGHT LBS
SD84MC-18-152	3772934021	152.00	69.00	221.00	1.75	2.00	10.50	14.75	3.00	2.13	3.12	1, 3/4	3.12	3/4	9.5	24.6	770
SD84MC-21-176	3772934026	176.25	69.00	245.25	1.75	2.00	10.50	14.75	3.00	2.13	3.12	1 1/4	3.12	3/4	9.5	28.5	765
SD84MC-18-176	3772934020	176.25	69.00	245.25	1.75	2.00	10.50	14.75	3.00	2.13	3.12	1, 3/4	3.12	3/4	9.5	28.5	770
SD84MC-20-406	3772934025	406.00	135.50	541.50	1.75	2.00	66.50	14.75	3.00	2.13	3.12	1, 3/4	3.12	3/4	19.2	65.8	1400
SD84MC-23-406	3772934031	406.00	135.50	541.50	1.75	2.00	66.50	14.75	3.00	2.13	3.12	1 1/4	3.12	3/4	19.2	65.8	1400
SD85MC-15-220	3772935023	220.25	69.25	289.50	1.75	2.00	10.75	14.75	3.00	2.13	3.12	1, 3/4	3.12	3/4	7.1	31.2	830
SD85MC-16-220	3772935024	220.25	69.25	289.50	1.75	2.00	10.75	14.75	3.00	2.13	3.25	1 1/4	3.25	3/4	7.1	31.2	830
SD85MC-20-384	3772935032	384.00	106.00	490.00	2.00	2.00	46.25	16.00	2.00	2.00	4.12	1 1/4	4.12	1	13.1	54.5	1127
SD95MC-5-220	3773135012	220.25	69.75	290.00	3.00	2.50	11.38	17.50	3.00	2.50	3.88	1 1/2	3.88	1	11.5	43.1	1065
SD95MC-6-220	3773135013	220.25	69.75	290.00	3.00	2.50	11.38	17.50	3.00	2.50	3.88	1.5, 1	3.88	1	11.5	43.1	1065
SD95MC-7-239	3773135017	239.25	75.00	314.25	3.00	2.63	56.00	17.25	3.00	2.00	4.62	#20	4.62	#12	13.9	46.9	1160
SD96MC-5-412	3773136006	412.00	99.62	511.62	2.00	2.00	46.25	16.00	3.00	2.00	4.12	1 1/4	4.12	1	14.8	71.5	1545
SD96MC-5-456	3773136007	456.00	107.00	563.00	2.00	2.00	46.25	16.00	3.00	2.00	4.12	1 1/4	4.12	1	16.1	79.2	1645
SD96MC-5-480	3773136008	480.00	110.88	590.88	2.00	2.00	46.25	16.00	3.00	2.00	4.12	1 1/4	4.12	1	16.7	83.3	1710

Note: SD84MC-18-, SD84MC-20-, SD85MC-15-, and SD95MC-6- are 3 Port Quick Sweep Design.

Note; Diameter G is for a nominal pin size, for actual hole size refer to print.

100 Series Standard Build Piston Rod Cylinders

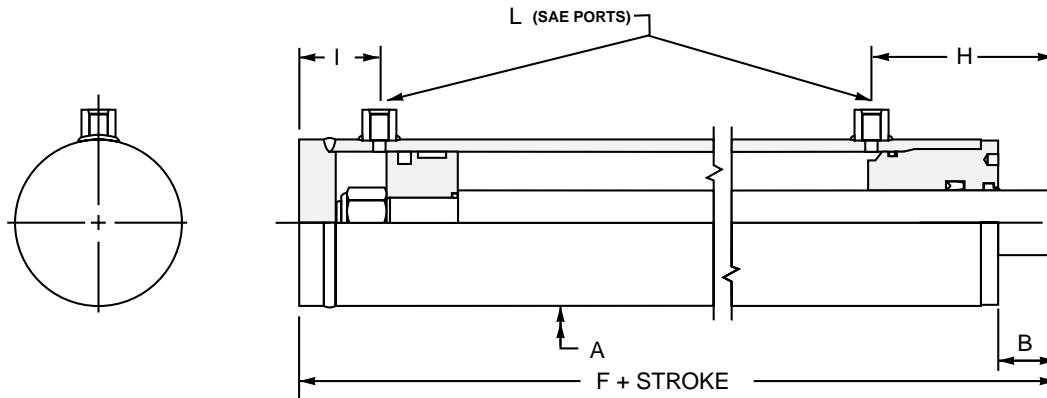

2500 PSI STANDARD DUTY 100 SERIES CYLINDER FEATURES

- * COLD DRAWN (HIGH IMPACT) 75,000 MIN. YIELD D.O.M. TUBING
- * GROUND & POLISHED, HARD CHROME PLATED RODS (75,000 min. yeild)
- * WELDED STYLE CONSTRUCTION CERTIFIED TO A.W.S. B2.1
- * INTERNALLY THREADED HEAD DESIGN WITH BUTTRESS THREADS

- * HIGHEST QUALITY SEAL CONFIGURATIONS COMPATIBLE WITH PETROLEUM BASE FLUIDS
- * DUCTILE IRON HEAD GLAND & PISTON
- * PISTON UTILIZES WEAR BEARINGS
- * NYLON INSERTED LOCK NUT
- * STANDARD PAINT; GREY PRIMER

Bore	Rod	A	B	F	H	I	L	Maximum Stroke	Part#
1.50	.75	2.00	1.38	5.75	3.31	1.31	#4	18	104-**.**. **
	1.00	2.00	1.50	6.00	3.56	1.31	#4	34	106-**.**. **
2.00	1.00	2.50	1.38	6.25	3.62	1.38	#6	25	110-**.**. **
	1.12	2.50	1.50	6.25	3.62	1.38	#6	31	112-**.**. **
	1.25	2.50	1.50	6.50	3.88	1.38	#6	39	114-**.**. **
2.50	1.25	3.00	1.50	6.50	3.62	1.62	#6	31	118-**.**. **
	1.50	3.00	1.56	7.00	4.06	1.69	#6	45	120-**.**. **
3.00	1.25	3.50	1.56	7.00	4.00	1.75	#8	26	124-**.**. **
	1.50	3.50	1.44	7.00	3.88	1.88	#8	38	126-**.**. **
	1.75	3.50	1.44	7.00	3.88	1.88	#8	52	128-**.**. **
	2.00	3.50	1.44	7.25	4.12	1.88	#8	66	130-**.**. **
3.50	1.50	4.00	1.56	7.25	4.00	2.00	#8	32	134-**.**. **
	1.75	4.00	1.56	7.25	4.00	2.00	#8	44	136-**.**. **
	2.00	4.00	1.56	7.25	4.00	2.00	#8	58	138-**.**. **
4.00	1.50	4.50	1.44	7.25	3.88	2.12	#8	28	142-**.**. **
	1.75	4.50	1.50	7.50	3.94	2.31	#8	39	144-**.**. **
	2.00	4.50	1.50	7.50	3.94	2.31	#8	51	146-**.**. **
	2.50	4.50	1.50	7.75	4.19	2.31	#8	78	148-**.**. **
4.50	1.75	5.00	1.38	7.75	3.81	2.44	#8	34	152-**.**. **
	2.00	5.00	1.38	7.75	3.81	2.44	#8	45	154-**.**. **
	2.25	5.00	1.38	7.75	3.81	2.44	#8	58	156-**.**. **
5.00	2.00	5.62	1.50	8.25	3.94	2.81	#8	40	160-**.**. **
	2.50	5.62	1.50	8.50	4.19	2.81	#8	62	162-**.**. **
	3.00	5.62	1.50	8.50	4.19	2.81	#8	89	164-**.**. **

Ordering Information: * TO COMPLETE PART#; REPLACE (**.**) WITH STROKE REQUIRED

- * For stroke lengths longer than 60", add 1" for every 10" of stroke to the "F" dimension.
- * Other port sizes and locations available upon request.
- * Consult factory for longer stroke and or higher pressure requirements.
- * Maximum stroke based on full load at full extension.

200 Series Standard Build Piston Rod Cylinders

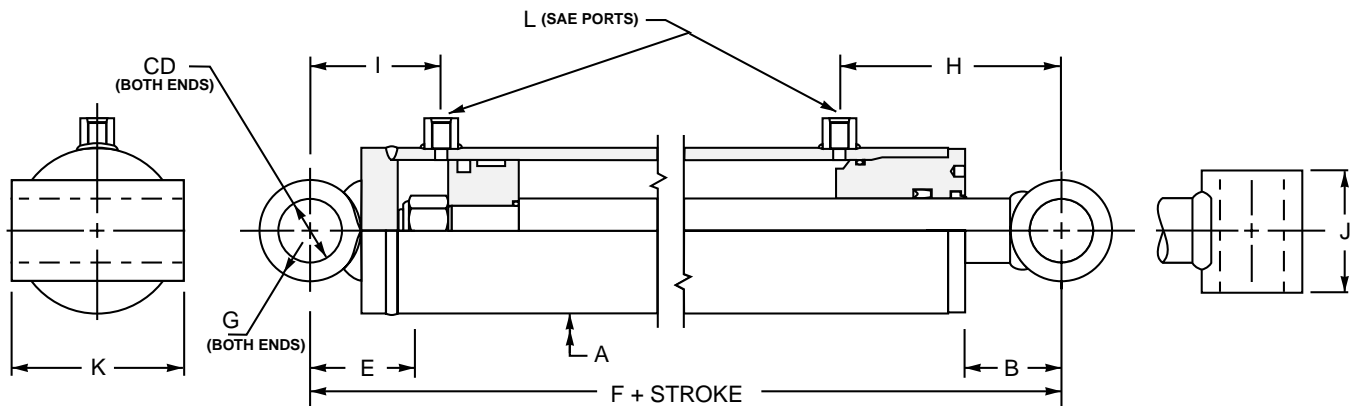

2500 PSI STANDARD DUTY 200 SERIES CYLINDER FEATURES

- * COLD DRAWN (HIGH IMPACT) 75,000 MIN. YIELD D.O.M. TUBING
- * GROUND & POLISHED, HARD CHROME PLATED RODS (75,000 min. yeild)
- * WELDED STYLE CONSTRUCTION CERTIFIED TO A.W.S. B2.1
- * INTERNALLY THREADED HEAD DESIGN WITH BUTTRESS THREADS

- * HIGHEST QUALITY SEAL CONFIGURATIONS COMPATIBLE WITH PETROLEUM BASE FLUIDS
- * DUCTILE IRON HEAD GLAND & PISTON
- * PISTON UTILIZES WEAR BEARINGS
- * NYLON INSERTED LOCK NUT
- * STANDARD PAINT; GREY PRIMER

Bore	Rod	A	B	CD	E	F	G	H	I	J	K	L	Maximum Stroke	Part#
1.50	.75	2.00	1.31	.75	.56	6.25	.62	3.25	1.88	2.50	2.50	#4	18	204-**-**
	1.00	2.00	1.19	.75	.56	6.25	.62	3.25	1.88	2.50	2.50	#4	34	206-**-**
2.00	1.00	2.50	1.44	1.00	.69	7.00	.75	3.69	2.06	2.50	3.00	#6	25	210-**-**
	1.12	2.50	1.56	1.00	.69	7.00	.75	3.69	2.06	2.50	3.00	#6	31	212-**-**
2.50	1.25	2.50	1.31	1.00	.69	7.00	.75	3.69	2.06	2.50	3.00	#6	39	214-**-**
	1.25	3.00	1.69	1.00	.81	7.50	.88	3.81	2.44	2.50	3.25	#6	31	218-**-**
3.00	1.50	3.00	1.50	1.00	.81	7.75	.88	4.00	2.50	2.50	3.25	#6	45	220-**-**
	1.25	3.50	1.50	1.00	.81	7.75	.88	3.94	2.56	2.50	3.75	#8	26	224-**-**
3.50	1.50	3.50	1.38	1.00	.81	7.75	.88	3.81	2.69	2.50	3.75	#8	38	226-**-**
	1.75	3.50	1.38	1.00	.81	7.75	.88	3.81	2.69	2.50	3.75	#8	52	228-**-**
4.00	2.00	3.50	1.38	1.00	.81	8.00	.88	4.06	2.69	2.50	3.75	#8	66	230-**-**
	1.50	4.00	1.44	1.25	.88	8.00	1.00	3.88	2.88	2.75	4.25	#8	32	234-**-**
4.50	1.75	4.00	1.44	1.25	.88	8.00	1.00	3.88	2.88	2.75	4.25	#8	44	236-**-**
	2.00	4.00	1.44	1.25	.88	8.00	1.00	3.88	2.88	2.75	4.25	#8	58	238-**-**
5.00	1.50	4.50	1.56	1.25	.88	8.25	1.00	4.00	3.00	2.75	4.75	#8	28	242-**-**
	1.75	4.50	1.62	1.25	.88	8.50	1.00	4.06	3.19	2.75	4.75	#8	39	244-**-**
5.50	2.00	4.50	1.62	1.25	.88	8.50	1.00	4.06	3.19	2.75	4.75	#8	51	246-**-**
	2.50	4.50	1.62	1.25	.88	8.75	1.00	4.31	3.19	2.75	4.75	#8	78	248-**-**
6.00	1.75	5.00	1.50	1.25	.88	8.75	1.00	3.94	3.31	2.75	5.25	#8	34	252-**-**
	2.00	5.00	1.50	1.25	.88	8.75	1.00	3.94	3.31	2.75	5.25	#8	45	254-**-**
6.50	2.25	5.00	1.50	1.25	.88	8.75	1.00	3.94	3.31	2.75	5.25	#8	58	256-**-**
	2.00	5.62	1.88	1.50	1.12	9.75	1.25	4.31	3.94	2.75	6.00	#8	40	260-**-**
7.00	2.50	5.62	1.88	1.50	1.12	10.00	1.25	4.56	3.94	2.75	6.00	#8	62	262-**-**
	3.00	5.62	1.88	1.50	1.12	10.00	1.25	4.56	3.94	4.25	6.00	#8	89	264-**-**

Ordering Information: * TO COMPLETE PART#; REPLACE (** **) WITH STROKE REQUIRED

- * For stroke lengths longer than 60", add 1" for every 10" of stroke to the "F" dimension.
- * Other port sizes and locations available upon request.
- * Consult factory for longer stroke and or higher pressure requirements.
- * Maximum stroke based on full load at full extension.

300 Series Standard Build Piston Rod Cylinders

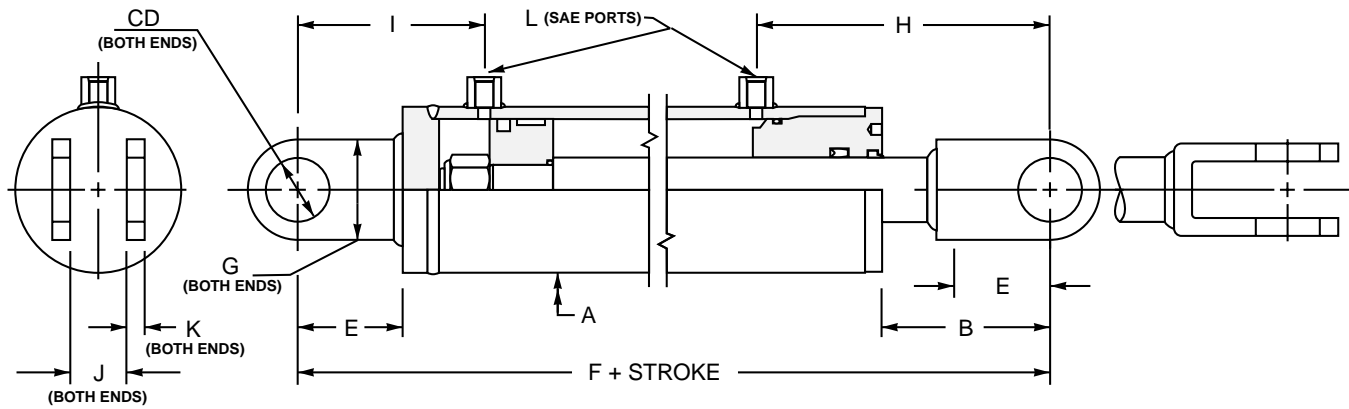

2500 PSI STANDARD DUTY 300 SERIES CYLINDER FEATURES

- * COLD DRAWN (HIGH IMPACT) 75,000 MIN. YIELD D.O.M. TUBING
- * GROUND & POLISHED, HARD CHROME PLATED RODS (75,000 min. yeild)
- * WELDED STYLE CONSTRUCTION CERTIFIED TO A.W.S. B2.1
- * INTERNALLY THREADED HEAD DESIGN WITH BUTTRESS THREADS

- * HIGHEST QUALITY SEAL CONFIGURATIONS COMPATIBLE WITH PETROLEUM BASE FLUIDS
- * DUCTILE IRON HEAD GLAND & PISTON
- * PISTON UTILIZES WEAR BEARINGS
- * NYLON INSERTED LOCK NUT
- * STANDARD PAINT; GREY PRIMER

Bore	Rod	A	B	CD	E	F	G	H	I	J	K	L	Maximum Stroke	Part#
1.50	.75	2.00	3.00	.75	1.62	9.00	1.75	4.94	2.94	1.06	.38	#4	18	304-**-**
	1.00	2.00	2.88	.75	1.62	9.00	1.75	4.94	2.94	1.06	.38	#4	34	306-**-**
2.00	1.00	2.50	3.88	1.00	2.00	10.25	2.00	5.62	3.38	1.25	.50	#6	25	310-**-**
	1.12	2.50	3.50	1.00	2.00	10.25	2.00	5.62	3.38	1.25	.50	#6	31	312-**-**
2.50	1.25	2.50	3.25	1.00	2.00	10.25	2.00	5.62	3.38	1.25	.50	#6	39	314-**-**
	1.25	3.00	3.25	1.00	2.00	10.25	2.00	5.38	3.62	1.25	.50	#6	31	318-**-**
3.00	1.50	3.00	3.06	1.00	2.00	10.25	2.00	5.56	3.44	1.25	.50	#6	45	320-**-**
	1.25	3.50	3.06	1.00	2.00	10.25	2.00	5.50	3.50	1.25	.50	#8	26	324-**-**
3.50	1.50	3.50	3.06	1.00	2.00	10.25	2.00	5.50	3.50	1.25	.50	#8	38	326-**-**
	1.75	3.50	3.06	1.00	2.00	10.25	2.00	5.50	3.50	1.25	.50	#8	52	328-**-**
4.00	2.00	3.50	3.06	1.00	2.00	10.25	2.00	5.75	3.25	1.25	.50	#8	66	330-**-**
	1.50	4.00	3.06	1.00	2.00	10.25	2.00	5.50	3.50	1.25	.50	#8	32	334-**-**
4.50	1.75	4.00	3.06	1.00	2.00	10.25	2.00	5.50	3.50	1.25	.50	#8	44	336-**-**
	2.00	4.00	3.06	1.00	2.00	10.25	2.00	5.50	3.50	1.25	.50	#8	58	338-**-**
5.00	1.50	4.50	3.06	1.00	2.00	10.25	2.00	5.50	3.50	1.25	.50	#8	28	342-**-**
	1.75	4.50	3.06	1.00	2.00	10.25	2.00	5.50	3.50	1.25	.50	#8	39	344-**-**
5.50	2.00	4.50	3.06	1.00	2.00	10.25	2.00	5.50	3.50	1.25	.50	#8	51	346-**-**
	2.50	4.50	3.25	1.00	2.00	11.25	2.00	5.94	4.06	1.25	.50	#8	78	348-**-**
6.00	1.75	5.00	3.38	1.25	2.00	11.75	2.50	5.81	4.44	1.62	.75	#8	34	352-**-**
	2.00	5.00	3.38	1.25	2.00	11.75	2.50	5.81	4.44	1.62	.75	#8	45	354-**-**
6.50	2.25	5.00	3.38	1.25	2.00	11.75	2.50	5.81	4.44	1.62	.75	#8	58	356-**-**
	2.00	5.62	4.25	1.50	2.50	13.50	3.00	6.69	5.31	2.12	1.00	#8	40	360-**-**
7.00	2.50	5.62	4.25	1.50	2.50	13.75	3.00	6.94	5.31	2.12	1.00	#8	62	362-**-**
	3.00	5.62	4.25	1.50	2.50	13.75	3.00	6.94	5.31	2.12	1.00	#8	89	364-**-**

Ordering Information: * TO COMPLETE PART#; REPLACE (** **) WITH STROKE REQUIRED

- * For stroke lengths longer than 60", add 1" for every 10" of stroke to the "F" dimension.
- * Other port sizes and locations available upon request.
- * Consult factory for longer stroke and or higher pressure requirements.
- * Maximum stroke based on full load at full extension.

400 Series Standard Build Piston Rod Cylinders

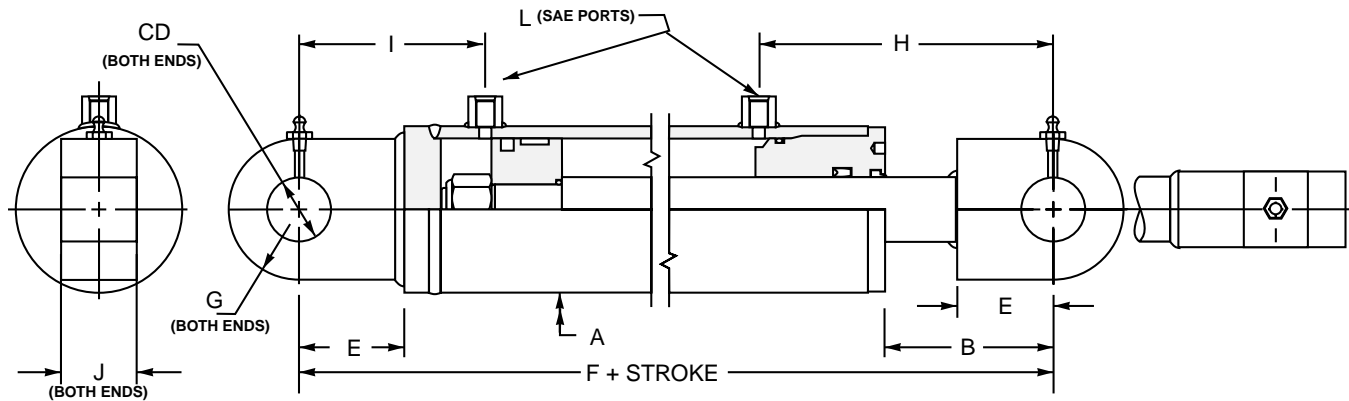

2500 PSI STANDARD DUTY 400 SERIES CYLINDER FEATURES

- * COLD DRAWN (HIGH IMPACT) 75,000 MIN. YIELD D.O.M. TUBING
- * GROUND & POLISHED, HARD CHROME PLATED RODS (75,000 min. yeild)
- * WELDED STYLE CONSTRUCTION CERTIFIED TO A.W.S. B2.1
- * INTERNALLY THREADED HEAD DESIGN WITH BUTTRESS THREADS

- * HIGHEST QUALITY SEAL CONFIGURATIONS COMPATIBLE WITH PETROLEUM BASE FLUIDS
- * DUCTILE IRON HEAD GLAND & PISTON
- * PISTON UTILIZES WEAR BEARINGS
- * NYLON INSERTED LOCK NUT
- * STANDARD PAINT; GREY PRIMER

Bore	Rod	A	B	CD	E	F	G	H	I	J	L	Maximum Stroke	Part#
1.50	.75	2.00	2.12	.75	1.50	8.00	.75	4.06	2.81	.75	#4	18	404-**.**. **
	1.00	2.00	2.00	.75	1.50	8.00	.75	4.06	2.81	1.00	#4	34	406-**.**. **
2.00	1.00	2.50	2.62	1.00	2.00	9.50	1.00	4.88	3.38	1.00	#6	25	410-**.**. **
	1.12	2.50	2.75	1.00	2.00	9.50	1.00	4.88	3.38	1.25	#6	31	412-**.**. **
	1.25	2.50	2.50	1.00	2.00	9.50	1.00	4.88	3.38	1.25	#6	39	414-**.**. **
2.50	1.25	3.00	2.75	1.00	2.00	9.75	1.00	4.88	3.62	1.25	#6	31	418-**.**. **
	1.50	3.00	2.56	1.00	2.00	10.00	1.00	5.06	3.69	1.50	#6	45	420-**.**. **
3.00	1.25	3.50	2.81	1.00	2.00	10.25	1.00	5.25	3.75	1.25	#8	26	424-**.**. **
	1.50	3.50	2.69	1.00	2.00	10.25	1.00	5.12	3.88	1.50	#8	38	426-**.**. **
	1.75	3.50	2.69	1.00	2.00	10.25	1.00	5.12	3.88	1.75	#8	52	428-**.**. **
	2.00	3.50	2.69	1.00	2.00	10.50	1.00	5.38	3.88	2.00	#8	66	430-**.**. **
3.50	1.50	4.00	3.06	1.25	2.50	11.25	1.25	5.50	4.50	1.50	#8	32	434-**.**. **
	1.75	4.00	3.06	1.25	2.50	11.25	1.25	5.50	4.50	1.75	#8	44	436-**.**. **
	2.00	4.00	3.06	1.25	2.50	11.25	1.25	5.50	4.50	2.00	#8	58	438-**.**. **
4.00	1.50	4.50	3.19	1.25	2.50	11.50	1.25	5.62	4.62	1.50	#8	28	442-**.**. **
	1.75	4.50	3.25	1.25	2.50	11.75	1.25	5.69	4.81	1.75	#8	39	444-**.**. **
	2.00	4.50	3.25	1.25	2.50	11.75	1.25	5.69	4.81	2.00	#8	51	446-**.**. **
	2.50	4.50	3.25	1.25	2.50	12.00	1.25	5.94	4.81	2.50	#8	78	448-**.**. **
4.50	1.75	5.00	3.12	1.25	2.50	12.00	1.25	5.56	4.94	1.75	#8	34	452-**.**. **
	2.00	5.00	3.12	1.25	2.50	12.00	1.25	5.56	4.94	2.00	#8	45	454-**.**. **
	2.25	5.00	3.12	1.25	2.50	12.00	1.25	5.56	4.94	2.50	#8	58	456-**.**. **
5.00	2.00	5.62	3.25	1.50	2.50	12.50	1.50	5.69	5.31	2.00	#8	40	460-**.**. **
	2.50	5.62	3.25	1.50	2.50	12.75	1.50	5.94	5.31	2.50	#8	62	462-**.**. **
	3.00	5.62	3.25	1.50	2.50	12.75	1.50	5.94	5.31	3.00	#8	89	464-**.**. **

Ordering Information: * TO COMPLETE PART#; REPLACE (**.**) WITH STROKE REQUIRED

- * For stroke lengths longer than 60", add 1" for every 10" of stroke to the "F" dimension.
- * Other port sizes and locations available upon request.
- * Consult factory for longer stroke and or higher pressure requirements.
- * Maximum stroke based on full load at full extension.

600 Series Standard Build Piston Rod Cylinders

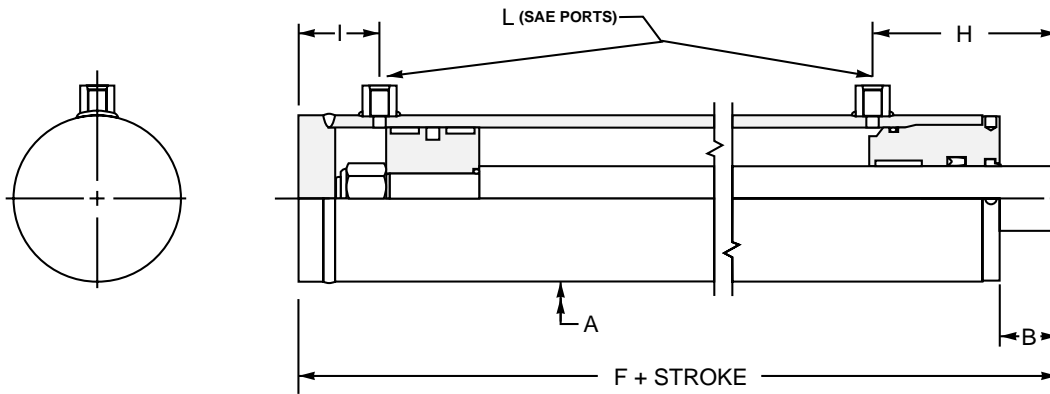

3000 PSI HEAVY DUTY 600 SERIES CYLINDER FEATURES

- * PISTON AND HEAD GLAND HAVE INCREASED BEARING SURFACE AREA
- * COLD DRAWN (HIGH IMPACT) 75,000 MIN. YIELD D.O.M. TUBING
- * GROUND & POLISHED, HARD CHROME PLATED RODS (75,000 min. yeild)
- * WELDED STYLE CONSTRUCTION CERTIFIED TO A.W.S. B2.1

- * INTERNALLY THREADED HEAD DESIGN WITH BUTTRESS THREADS
- * HIGHEST QUALITY SEAL CONFIGURATIONS COMPATIBLE WITH PETROLEUM BASE FLUIDS
- * DUCTILE IRON HEAD GLAND & PISTON
- * PISTON UTILIZES WEAR BEARINGS
- * NYLON INSERTED LOCK NUT
- * STANDARD PAINT; GREY PRIMER

Bore	Rod	A	B	F	H	I	L	Maximum Stroke	Part#
3.00	1.75	3.50	1.56	8.25	3.94	1.94	#6	47	604-**-**
	2.00	3.50	1.56	8.25	3.94	1.94	#6	53	606-**-**
3.50	1.75	4.00	1.44	8.25	3.88	2.00	#8	40	610-**-**
	2.00	4.00	1.50	8.50	3.94	2.19	#8	52	612-**-**
4.00	2.00	4.62	1.50	9.25	4.56	2.31	#8	46	616-**-**
	2.50	4.62	1.50	9.25	4.56	2.31	#8	72	618-**-**
	3.00	4.62	1.62	10.00	5.44	2.56	#8	99	620-**-**
4.50	2.00	5.12	1.50	9.50	4.62	2.50	#10	40	624-**-**
	2.50	5.12	1.50	9.75	4.62	2.75	#10	64	626-**-**
	3.00	5.12	1.50	9.75	4.62	2.75	#10	90	628-**-**
5.00	3.50	5.12	1.50	10.00	5.38	2.62	#10	115	630-**-**
	2.00	5.62	1.50	9.25	4.44	2.44	#12	36	634-**-**
	2.50	5.62	1.62	10.25	5.00	2.69	#12	57	636-**-**
	3.00	5.62	1.62	10.25	5.00	2.69	#12	82	638-**-**
5.50	3.50	5.62	1.50	10.00	4.88	2.56	#12	108	640-**-**
	4.00	5.62	1.62	10.25	5.56	2.69	#12	130	642-**-**
	2.50	6.12	1.44	10.25	4.81	2.75	#12	52	646-**-**
	3.00	6.12	1.56	10.25	4.94	2.62	#12	75	648-**-**
6.00	3.50	6.12	1.56	10.25	4.94	2.62	#12	100	650-**-**
	4.00	6.12	1.69	10.50	5.06	2.75	#12	124	652-**-**
	4.50	6.12	1.56	11.00	5.50	3.38	#12	144	654-**-**
	2.50	6.75	1.62	10.50	5.00	2.81	#12	48	658-**-**
7.00	3.00	6.75	1.50	10.25	4.88	2.69	#12	70	660-**-**
	3.50	6.75	1.50	10.25	4.88	2.69	#12	94	662-**-**
	4.00	6.75	1.62	10.50	5.00	2.81	#12	120	664-**-**
	2.50	8.00	1.69	11.25	5.62	2.75	#16	40	668-**-**
8.00	3.00	8.00	1.69	11.25	5.62	2.75	#16	60	670-**-**
	3.50	8.00	1.69	11.25	5.62	2.75	#16	82	672-**-**
	4.00	8.00	1.56	11.75	5.50	3.38	#16	107	674-**-**
8.00	3.50	9.00	1.50	13.00	5.69	3.44	#16	71	678-**-**
	4.00	9.00	1.50	13.00	5.69	3.44	#16	94	680-**-**
	4.50	9.00	1.50	13.00	5.69	3.44	#16	118	682-**-**

Ordering Information: * TO COMPLETE PART#; REPLACE (** **) WITH STROKE REQUIRED

- * For stroke lengths longer than 60", add 1" for every 10" of stroke to the "F" dimension.
- * Other port sizes and locations available upon request.
- * Consult factory for longer stroke and or higher pressure requirements.
- * Maximum stroke based on full load at full extension.

700 Series Standard Build Piston Rod Cylinders

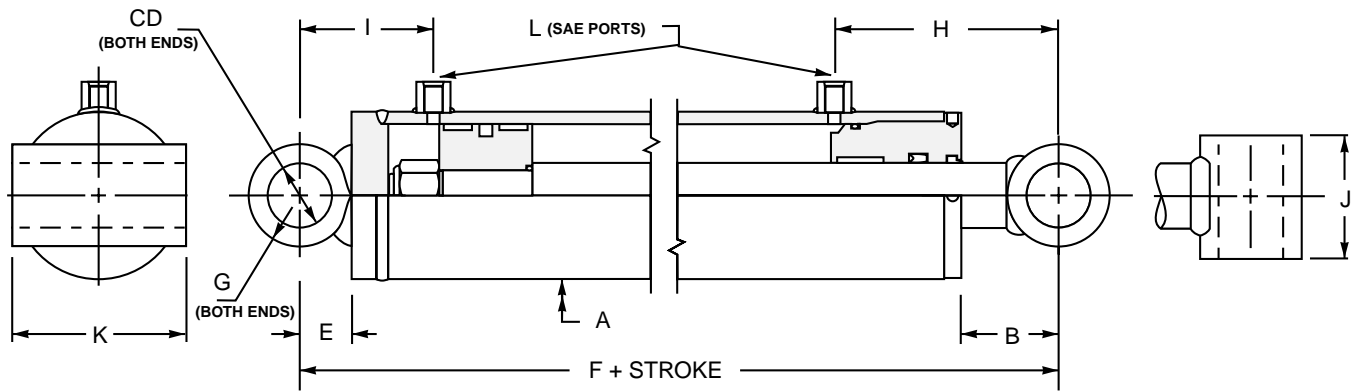

3000 PSI HEAVY DUTY 700 SERIES CYLINDER FEATURES

- * PISTON AND HEAD GLAND HAVE INCREASED BEARING SURFACE AREA
- * COLD DRAWN (HIGH IMPACT) 75,000 MIN. YIELD D.O.M. TUBING
- * GROUND & POLISHED, HARD CHROME PLATED RODS (75,000 min. yeild)
- * WELDED STYLE CONSTRUCTION CERTIFIED TO A.W.S. B2.1

- * INTERNALLY THREADED HEAD DESIGN WITH BUTTRESS THREADS
- * HIGHEST QUALITY SEAL CONFIGURATIONS COMPATIBLE WITH PETROLEUM BASE FLUIDS
- * DUCTILE IRON HEAD GLAND & PISTON
- * PISTON UTILIZES WEAR BEARINGS
- * NYLON INSERTED LOCK NUT
- * STANDARD PAINT; GREY PRIMER

Bore	Rod	A	B	CD	E	F	G	H	I	J	K	L	Maximum Stroke	Part#
3.00	1.75	3.50	1.50	1.00	.81	9.00	.88	3.88	2.75	2.75	3.75	#6	47	704-***
	2.00	3.50	1.50	1.00	.81	9.00	.88	3.88	2.75	2.75	3.75	#6	53	706-***
3.50	1.75	4.00	1.56	1.25	.88	9.25	1.00	4.00	2.88	3.25	4.25	#8	40	710-***
	2.00	4.00	1.62	1.25	.88	9.50	1.00	4.06	3.06	3.25	4.25	#8	52	712-***
4.00	2.00	4.62	2.12	1.50	1.12	11.00	1.25	5.19	3.44	3.00	4.75	#8	46	716-***
	2.50	4.62	2.12	1.50	1.12	11.00	1.25	5.19	3.44	3.00	4.75	#8	72	718-***
	3.00	4.62	2.00	1.50	1.12	11.50	1.25	5.81	3.69	4.25	4.75	#8	99	720-***
4.50	2.00	5.12	1.88	1.50	1.12	11.00	1.25	5.00	3.62	3.00	5.50	#10	40	724-***
	2.50	5.12	2.12	1.50	1.12	11.50	1.25	5.25	3.88	3.00	5.50	#10	64	726-***
	3.00	5.12	2.12	1.50	1.12	11.50	1.25	5.25	3.88	4.25	5.50	#10	90	728-***
5.00	3.50	5.12	2.12	1.50	1.12	11.75	1.25	6.00	3.75	4.25	5.50	#10	115	730-***
	2.00	5.62	2.25	1.75	1.25	11.25	1.38	5.19	3.69	3.25	6.00	#12	36	734-***
	2.50	5.62	2.12	1.75	1.25	12.00	1.38	5.50	3.94	3.25	6.00	#12	57	736-***
	3.00	5.62	2.12	1.75	1.25	12.00	1.38	5.50	3.94	4.75	6.00	#12	82	738-***
5.50	3.50	5.62	2.00	1.75	1.25	11.75	1.38	5.38	3.81	4.75	6.00	#12	108	740-***
	4.00	5.62	2.12	1.75	1.25	12.00	1.38	6.06	3.94	4.75	6.00	#12	130	742-***
	2.50	6.12	2.19	1.75	1.25	12.25	1.38	5.56	4.00	3.25	7.00	#12	52	746-***
	3.00	6.12	2.06	1.75	1.25	12.00	1.38	5.44	3.88	4.75	7.00	#12	75	748-***
6.00	3.50	6.12	2.06	1.75	1.25	12.00	1.38	5.44	3.88	4.75	7.00	#12	100	750-***
	4.00	6.12	2.19	1.75	1.25	12.25	1.38	5.56	4.00	4.75	7.00	#12	124	752-***
	4.50	6.12	2.06	1.75	1.25	12.75	1.38	6.00	4.62	5.50	7.00	#12	144	754-***
	2.50	6.75	2.25	2.00	1.38	12.50	1.50	5.62	4.19	3.50	7.00	#12	48	758-***
7.00	3.00	6.75	2.12	2.00	1.38	12.25	1.50	5.50	4.06	3.50	7.00	#12	70	760-***
	3.50	6.75	2.12	2.00	1.38	12.25	1.50	5.50	4.06	4.75	7.00	#12	94	762-***
	4.00	6.75	2.25	2.00	1.38	12.50	1.50	5.62	4.19	5.50	7.00	#12	120	764-***
8.00	2.50	8.00	2.81	2.50	1.62	14.00	1.75	6.75	4.38	5.00	8.25	#16	40	768-***
	3.00	8.00	2.81	2.50	1.62	14.00	1.75	6.75	4.38	5.00	8.25	#16	60	770-***
	3.50	8.00	2.81	2.50	1.62	14.00	1.75	6.75	4.38	5.00	8.25	#16	82	772-***
8.00	4.00	8.00	2.69	2.50	1.62	14.50	1.75	6.62	5.00	5.00	8.25	#16	107	774-***
	3.50	9.00	2.88	3.00	1.88	16.25	2.00	7.06	5.31	5.00	9.25	#16	71	778-***
	4.00	9.00	2.88	3.00	1.88	16.25	2.00	7.06	5.31	5.00	9.25	#16	94	780-***
4.50	9.00	2.88	3.00	1.88	16.25	2.00	7.06	5.31	5.00	9.25	#16	118	782-***	

Ordering Information: * TO COMPLETE PART#; REPLACE (**)** WITH STROKE REQUIRED

- * For stroke lengths longer than 60", add 1" for every 10" of stroke to the "F" dimension.
- * Other port sizes and locations available upon request.
- * Consult factory for longer stroke and or higher pressure requirements.
- * Maximum stroke based on full load at full extension.

800 Series Standard Build Piston Rod Cylinders

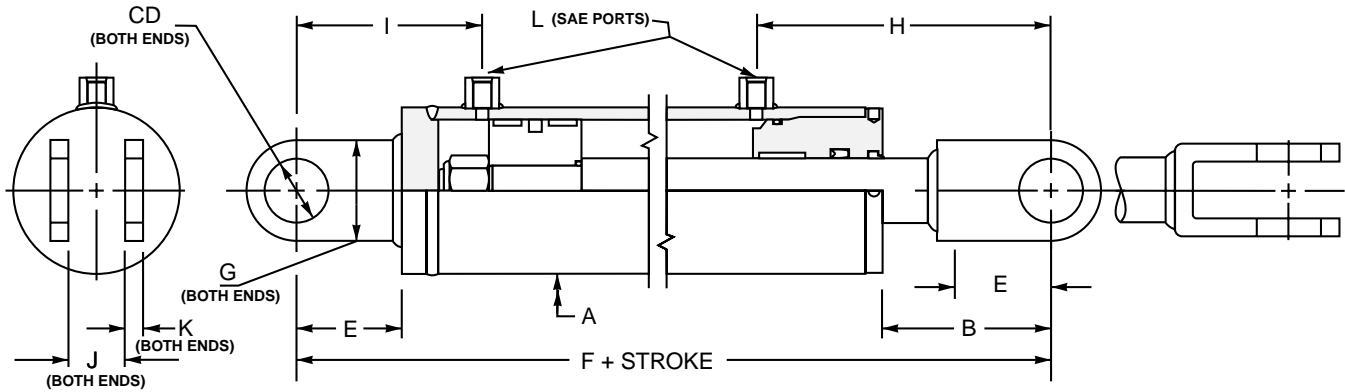

3000 PSI HEAVY DUTY 800 SERIES CYLINDER FEATURES

- * PISTON AND HEAD GLAND HAVE INCREASED BEARING SURFACE AREA
- * COLD DRAWN (HIGH IMPACT) 75,000 MIN. YIELD D.O.M. TUBING
- * GROUND & POLISHED, HARD CHROME PLATED RODS (75,000 min. yeild)
- * WELDED STYLE CONSTRUCTION CERTIFIED TO A.W.S. B2.1

- * INTERNALLY THREADED HEAD DESIGN WITH BUTTRESS THREADS
- * HIGHEST QUALITY SEAL CONFIGURATIONS COMPATIBLE WITH PETROLEUM BASE FLUIDS
- * DUCTILE IRON HEAD GLAND & PISTON
- * PISTON UTILIZES WEAR BEARINGS
- * NYLON INSERTED LOCK NUT
- * STANDARD PAINT; GREY PRIMER

Bore	Rod	A	B	CD	E	F	G	H	I	J	K	L	Maximum Stroke	Part#
3.00	1.75	3.50	3.31	1.00	2.00	12.00	2.00	5.75	3.94	1.25	.50	#6	47	804-**-**
	2.00	3.50	3.31	1.00	2.00	12.00	2.00	5.75	3.94	1.25	.50	#6	53	806-**-**
3.50	1.75	4.00	3.81	1.25	2.00	12.50	2.50	4.50	4.50	1.62	.75	#8	40	810-**-**
	2.00	4.00	3.50	1.25	2.00	12.50	2.50	5.94	4.69	1.62	.75	#8	52	812-**-**
4.00	2.00	4.62	4.25	1.50	2.00	14.00	3.00	7.31	4.31	1.62	1.00	#8	46	816-**-**
	2.50	4.62	4.25	1.50	2.00	14.00	3.00	7.31	4.31	1.62	1.00	#8	72	818-**-**
4.50	3.00	4.62	4.12	1.50	2.00	14.50	3.00	7.94	4.56	1.62	1.00	#8	99	820-**-**
	2.00	5.12	4.25	1.50	2.00	14.25	3.00	7.38	4.50	1.62	1.00	#10	40	824-**-**
	2.50	5.12	4.00	1.50	2.00	14.25	3.00	7.12	4.75	1.62	1.00	#10	64	826-**-**
	3.00	5.12	4.00	1.50	2.00	14.25	3.00	7.12	4.75	1.62	1.00	#10	90	828-**-**
5.00	3.50	5.12	4.00	1.50	2.00	14.50	3.00	7.88	4.62	1.62	1.00	#10	115	830-**-**
	2.00	5.62	4.25	1.75	2.25	14.25	3.50	7.19	4.69	2.12	1.00	#12	36	834-**-**
	2.50	5.62	4.12	1.75	2.25	15.00	3.50	7.50	4.94	2.12	1.00	#12	57	836-**-**
	3.00	5.62	4.12	1.75	2.25	15.00	3.50	7.50	4.94	2.12	1.00	#12	82	838-**-**
5.50	3.50	5.62	4.25	1.75	2.25	15.00	3.50	7.62	4.81	2.12	1.00	#12	108	840-**-**
	4.00	5.62	4.12	1.75	2.25	15.00	3.50	8.06	4.94	2.12	1.00	#12	130	842-**-**
	2.50	6.12	4.44	1.75	2.25	15.50	3.50	7.81	5.00	2.12	1.25	#12	52	846-**-**
	3.00	6.12	4.56	1.75	2.25	15.50	3.50	7.94	4.88	2.12	1.25	#12	75	848-**-**
6.00	3.50	6.12	4.56	1.75	2.25	15.50	3.50	7.94	4.88	2.12	1.25	#12	100	850-**-**
	4.00	6.12	4.44	1.75	2.25	15.50	3.50	7.81	5.00	2.12	1.25	#12	124	852-**-**
	4.50	6.12	4.56	1.75	2.25	16.25	3.50	8.50	5.63	2.12	1.25	#12	144	854-**-**
	2.50	6.75	4.62	2.00	2.50	16.00	4.00	8.00	5.31	2.62	1.25	#12	48	858-**-**
7.00	3.00	6.75	4.50	2.00	2.50	15.75	4.00	7.88	5.19	2.62	1.25	#12	70	860-**-**
	3.50	6.75	4.50	2.00	2.50	15.75	4.00	7.88	5.19	2.62	1.25	#12	94	862-**-**
	4.00	6.75	4.62	2.00	2.50	16.00	4.00	8.00	5.31	2.62	1.25	#12	120	864-**-**
	2.50	8.00	5.19	2.50	3.00	17.75	5.00	9.12	5.75	2.62	1.25	#16	40	868-**-**
8.00	3.00	8.00	5.19	2.50	3.00	17.75	5.00	9.12	5.75	2.62	1.25	#16	60	870-**-**
	3.50	8.00	5.19	2.50	3.00	17.75	5.00	9.12	5.75	2.62	1.25	#16	82	872-**-**
	4.00	8.00	5.06	2.50	3.00	18.25	5.00	9.00	6.38	2.62	1.25	#16	107	874-**-**
8.00	3.50	9.00	6.50	3.00	4.00	22.00	6.00	10.69	7.44	3.12	1.50	#16	71	878-**-**
	4.00	9.00	6.50	3.00	4.00	22.00	6.00	10.69	7.44	3.12	1.50	#16	94	880-**-**
	4.50	9.00	6.50	3.00	4.00	22.00	6.00	10.69	7.44	3.12	1.50	#16	118	882-**-**

Ordering Information: * TO COMPLETE PART#; REPLACE (** **) WITH STROKE REQUIRED

- * For stroke lengths longer than 60", add 1" for every 10" of stroke to the "F" dimension.
- * Other port sizes and locations available upon request.
- * Consult factory for longer stroke and or higher pressure requirements.
- * Maximum stroke based on full load at full extension.

900 Series Standard Build Piston Rod Cylinders

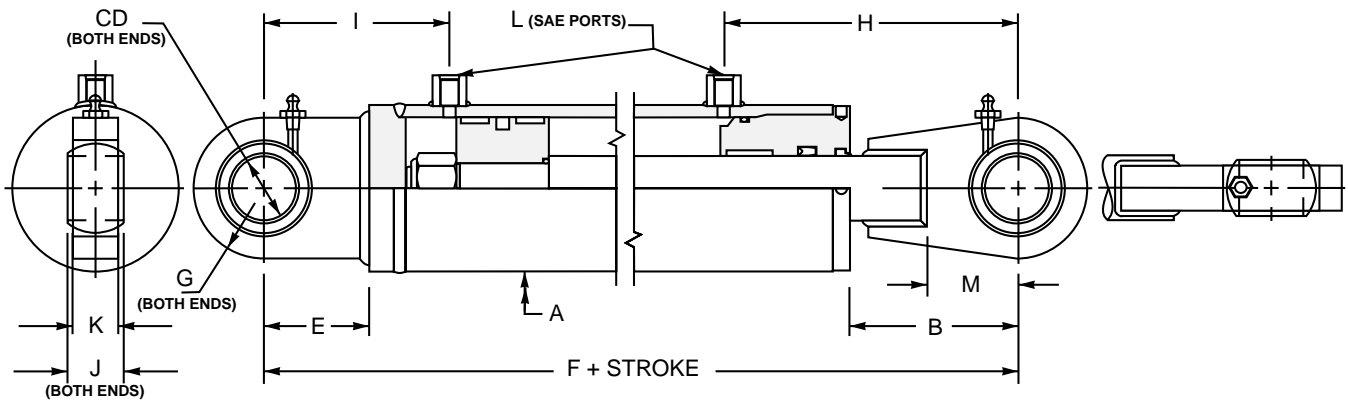

3000 PSI HEAVY DUTY 900 SERIES CYLINDER FEATURES

- * PISTON AND HEAD GLAND HAVE INCREASED BEARING SURFACE AREA
- * COLD DRAWN (HIGH IMPACT) 75,000 MIN. YIELD D.O.M. TUBING
- * GROUND & POLISHED, HARD CHROME PLATED RODS (75,000 min. yeild)
- * WELDED STYLE CONSTRUCTION CERTIFIED TO A.W.S. B2.1

- * INTERNALLY THREADED HEAD DESIGN WITH BUTTRESS THREADS
- * HIGHEST QUALITY SEAL CONFIGURATIONS COMPATIBLE WITH PETROLEUM BASE FLUIDS
- * DUCTILE IRON HEAD GLAND & PISTON
- * PISTON UTILIZES WEAR BEARINGS
- * NYLON INSERTED LOCK NUT
- * STANDARD PAINT; GREY PRIMER

Bore	Rod	A	B	CD	E	F	G	H	I	J	K	L	M	Maximum Stroke	Part#
3.00	1.75	3.50	3.81	1.25	2.00	12.50	1.50	6.19	3.94	1.093	.94	#6	2.00	47	904-**-**
	2.00	3.50	3.81	1.25	2.00	12.50	1.50	6.19	3.94	1.093	.94	#6	2.00	53	906-**-**
3.50	1.75	4.00	3.94	1.25	2.00	12.75	1.50	6.38	4.00	1.093	.94	#8	2.00	40	910-**-**
	2.00	4.00	3.75	1.25	2.00	12.75	1.50	6.19	4.19	1.093	.94	#8	2.00	52	912-**-**
4.00	2.00	4.62	4.00	1.50	2.50	14.25	1.88	7.06	4.81	1.312	1.12	#8	2.25	46	916-**-**
	2.50	4.62	4.00	1.50	2.50	14.25	1.88	7.06	4.81	1.312	1.12	#8	2.25	72	918-**-**
	3.00	4.62	4.12	1.50	2.50	15.00	1.88	7.94	5.06	1.312	1.12	#8	2.25	99	920-**-**
4.50	2.00	5.12	4.00	1.50	2.50	14.50	1.88	7.12	5.00	1.312	1.12	#10	2.25	40	924-**-**
	2.50	5.12	4.00	1.50	2.50	14.75	1.88	7.12	5.25	1.312	1.12	#10	2.25	64	926-**-**
	3.00	5.12	4.00	1.50	2.50	14.75	1.88	7.12	5.25	1.312	1.12	#10	2.25	90	928-**-**
	3.50	5.12	4.00	1.50	2.50	15.00	1.88	7.88	5.12	1.312	1.12	#10	2.25	115	930-**-**
5.00	2.00	5.62	4.50	1.75	2.50	14.75	2.00	7.44	4.94	1.531	1.31	#12	2.50	36	934-**-**
	2.50	5.62	4.62	1.75	2.50	15.75	2.00	8.00	5.19	1.531	1.31	#12	2.50	57	936-**-**
	3.00	5.62	4.62	1.75	2.50	15.75	2.00	8.00	5.19	1.531	1.31	#12	2.50	82	938-**-**
	3.50	5.62	4.50	1.75	2.50	15.50	2.00	7.88	5.06	1.531	1.31	#12	2.50	108	940-**-**
	4.00	5.62	4.62	1.75	2.50	15.75	2.00	8.56	5.19	1.531	1.31	#12	2.50	130	942-**-**
5.50	2.50	6.12	4.69	1.75	2.50	16.00	2.00	8.06	5.25	1.531	1.31	#12	2.50	52	946-**-**
	3.00	6.12	4.56	1.75	2.50	15.75	2.00	7.94	5.12	1.531	1.31	#12	2.50	75	948-**-**
	3.50	6.12	4.56	1.75	2.50	15.75	2.00	7.94	5.12	1.531	1.31	#12	2.50	100	950-**-**
	4.00	6.12	4.69	1.75	2.50	16.00	2.00	8.06	5.25	1.531	1.31	#12	2.50	124	952-**-**
	4.50	6.12	4.56	1.75	2.50	16.50	2.00	8.50	5.88	1.531	1.31	#12	2.50	144	954-**-**
6.00	2.50	6.75	4.88	2.00	2.75	16.50	2.38	8.25	5.56	1.750	1.50	#12	2.75	48	958-**-**
	3.00	6.75	4.75	2.00	2.75	16.25	2.38	8.12	5.44	1.750	1.50	#12	2.75	70	960-**-**
	3.50	6.75	4.75	2.00	2.75	16.25	2.38	8.12	5.44	1.750	1.50	#12	2.75	94	962-**-**
	4.00	6.75	4.88	2.00	2.75	16.50	2.38	8.25	5.56	1.750	1.50	#12	2.75	120	964-**-**
7.00	2.50	8.00	5.69	2.50	3.25	18.50	3.00	9.62	6.00	2.188	1.88	#16	3.25	40	968-**-**
	3.00	8.00	5.69	2.50	3.25	18.50	3.00	9.62	6.00	2.188	1.88	#16	3.25	60	970-**-**
	3.50	8.00	5.69	2.50	3.25	18.50	3.00	9.62	6.00	2.188	1.88	#16	3.25	82	972-**-**
	4.00	8.00	5.56	2.50	3.25	19.00	3.00	9.50	6.62	2.188	1.88	#16	3.25	107	974-**-**
8.00	3.50	9.00	6.50	3.00	4.25	22.25	3.75	10.69	7.69	2.625	2.25	#16	4.25	70	978-**-**
	4.00	9.00	6.50	3.00	4.25	22.25	3.75	10.69	7.69	2.625	2.25	#16	4.25	94	980-**-**
	4.50	9.00	6.50	3.00	4.25	22.25	3.75	10.69	7.69	2.625	2.25	#16	4.25	118	982-**-**

Ordering Information: * TO COMPLETE PART#; REPLACE (** **) WITH STROKE REQUIRED

- * For stroke lengths longer than 60", add 1" for every 10" of stroke to the "F" dimension.
- * Other port sizes and locations available upon request.
- * Consult factory for longer stroke and or higher pressure requirements.
- * Maximum stroke based on full load at full extension.

Telescopic Cylinder Application Data Form

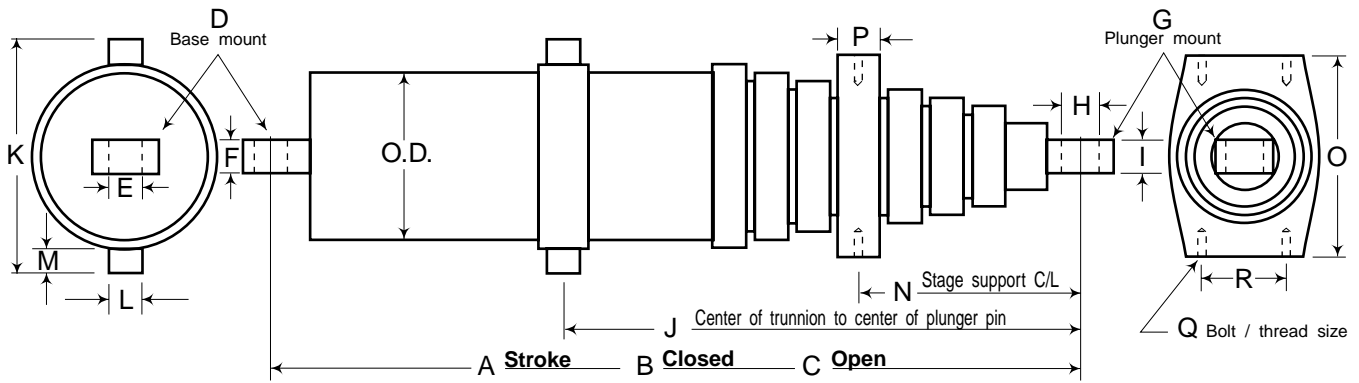

Cylinder application _____

Single- or Double-acting _____ System operating pressure Normal ____ Max. ____

O.D. of body _____ Is there a relief valve in system ____ Setting ____

O.D. largest moving stage _____ System flow in G.P.M Min. ____ Max. ____

Number of moving stages _____ System operating temp. Normal ____ Max. ____

Chrome or non-chrome stages _____ Fluid type _____

Mounting conditions ____Vert. ____Horz. ____Incline angle Load holding requirements _____

Any side or eccentric loading possible _____ Environmental condition _____

A : Total stroke _____ J : Plunger pin to trunnion C/L (if applicable) _____

B : Closed length _____ K : Trunnion overall width _____

C : Open length _____ L : Trunnion lug diameters _____

D : Base mount type or code _____ M : Trunnion lug lengths _____

E : Base pin diameter _____ N : Plunger pin to stage support (if applicable) _____

F : Base mount width _____ O : Stage support width _____

G : Plunger mount type or code _____ P : Stage support thickness _____

H : Plunger pin diameter _____ Q : Stage support bolt & thread size _____

I : Plunger mount width _____ R : Stage support bolt locations & C/L's _____

Special mounting (if applicable) _____

Extend port size and type _____ Extend port location _____

Retract port size and type _____ Retract port location _____

Special features or comments _____

Requested by: Firm _____ Current Quan. _____

Address _____ Future Quan. _____

City _____ State _____ Zip _____

Phone _____ Fax _____

Contact _____

Phone: (800) 848-5575 * 330-480-8431 * Fax (800) 694-3392 * 330-480-8432

Piston Rod Cylinder Application Data Form

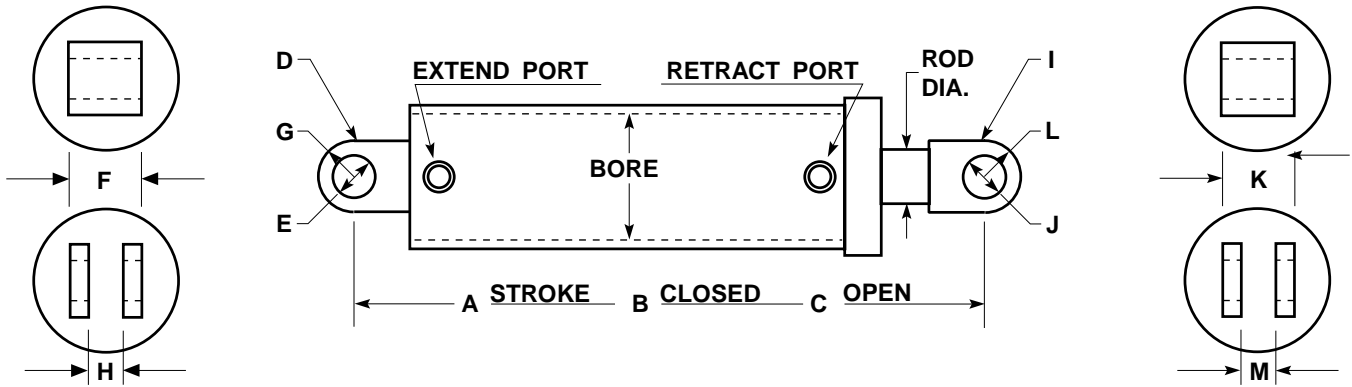

Cylinder application _____

Single- or Double-acting _____ System operating pressure Normal ____ Max. ____

Bore _____ Is there a relief valve in system ____ Setting ____

Rod diameter _____ System flow in G.P.M Min. ____ Max. ____

Head & gland design _____ System operating temp. Normal ____ Max. ____

Piston design _____ Fluid type _____

Mounting conditions ____Vert. ____Horz. ____Incline angle Load holding requirements _____

Any side or eccentric loading possible _____ Environmental condition _____

A : Total stroke _____

B : Closed length _____

C : Open length _____

D : Base mount type or code _____

I : Plunger mount type or code _____

E : Base pin diameter _____

J : Plunger pin diameter _____

F : Base mount width _____

K : Plunger mount width _____

G : Base mount radius _____

L : Plunger mount radius _____

H Base Clevis Gap (if applicable) _____

M : Plunger clevis gap (if applicable) _____

Special mounting (if applicable) _____

Extend port size and type _____ Extend port location _____

Retract port size and type _____ Retract port location _____

Special features or comments _____

Requested by: Firm _____ Current Quan. _____

Address _____ Future Quan. _____

City _____ State _____ Zip _____

Phone _____ Fax _____

Contact _____

Phone: (800) 848-5575 * 330-480-8431 * Fax (800) 694-3392 * 330-480-8432

Offer of Sale

The items described in this document are hereby offered for sale at prices to be established by Parker Hannifin Corporation, its subsidiaries and its authorized distributors. This offer and its acceptance by any customer ("Buyer") shall be governed by all of the following Terms and Conditions. Buyer's order for any item described in its document, when communicated to Parker Hannifin Corporation, its subsidiary or an authorized distributor ("Seller") verbally or in writing, shall constitute acceptance of this offer.

1. **Terms and Conditions of Sale:** All descriptions, quotations, proposals, offers, acknowledgments, acceptances and sales of Seller's products are subject to and shall be governed exclusively by the terms and conditions stated herein. Buyer's acceptance of any offer to sell is limited to these terms and conditions. Any terms or conditions in addition to, or inconsistent with those stated herein, proposed by Buyer in any acceptance of an offer by Seller, are hereby objected to. No such additional, different or inconsistent terms and conditions shall become part of the contract between Buyer and Seller unless expressly accepted in writing by Seller. Seller's acceptance of any offer to purchase by Buyer is expressly conditional upon Buyer's assent to all the terms and conditions stated herein, including any terms in addition to, or inconsistent with those contained in Buyer's offer. Acceptance of Seller's products shall in all events constitute such assent.

2. **Payment:** Payment shall be made by Buyer net 30 days from the date of delivery of the items purchased hereunder. Any claims by Buyer for omissions or shortages in a shipment shall be waived unless Seller receives notice thereof within 30 days after Buyer's receipt of the shipment.

3. **Delivery:** Unless otherwise provided on the face hereof, delivery shall be made F.O.B. Seller's plant. Regardless of the method of delivery, however, risk of loss shall pass to Buyer upon Seller's delivery to a carrier. Any delivery dates shown are approximate only and Seller shall have no liability for any delays in delivery.

4. **Warranty:** Seller warrants that the items sold hereunder shall be free from defects in material or workmanship for a period of 18 months from the date of shipment from Parker Hannifin Corporation. THIS WARRANTY COMPRISES THE SOLE AND ENTIRE WARRANTY PERTAINING TO ITEMS PROVIDED HEREUNDER. SELLER MAKES NO OTHER WARRANTY, GUARANTEE, OR REPRESENTATION OF ANY KIND WHATSOEVER. ALL OTHER WARRANTIES, INCLUDING BUT NOT LIMITED TO, MERCHANTABILITY AND FITNESS FOR PURPOSE, WHETHER EXPRESS, IMPLIED, OR ARISING BY OPERATION OF LAW, TRADE USAGE, OR COURSE OF DEALING ARE HEREBY DISCLAIMED.

NOTWITHSTANDING THE FOREGOING, THERE ARE NO WARRANTIES WHATSOEVER ON ITEMS BUILT OR ACQUIRED WHOLLY OR PARTIALLY, TO BUYER'S DESIGNS OR SPECIFICATIONS.

5. **Limitation Of Remedy:** SELLER'S LIABILITY ARISING FROM OR IN ANY WAY CONNECTED WITH THE ITEMS SOLD OR THIS CONTRACT SHALL BE LIMITED EXCLUSIVELY TO REPAIR OR REPLACEMENT OF THE ITEMS SOLD OR REFUND OF THE PURCHASE PRICE PAID BY BUYER, AT SELLER'S SOLE OPTION. IN NO EVENT SHALL SELLER BE LIABLE FOR ANY INCIDENTAL, CONSEQUENTIAL OR SPECIAL DAMAGES OF ANY KIND OR NATURE WHATSOEVER, INCLUDING BUT NOT LIMITED TO LOST PROFITS ARISING FROM OR IN ANY WAY CONNECTED WITH THIS AGREEMENT OR ITEMS SOLD HEREUNDER, WHETHER ALLEGED TO ARISE FROM BREACH OF CONTRACT, EXPRESS OR IMPLIED WARRANTY, OR IN TORT, INCLUDING WITHOUT LIMITATION, NEGLIGENCE, FAILURE TO WARN OR STRICT LIABILITY.

6. **Changes, Reschedules and Cancellations:** Buyer may request to modify the designs or specifications for the items sold hereunder as well as the quantities and delivery dates thereof, or may request to cancel all or part of this order, however, no such requested modification or cancellation shall become part of the contract between Buyer and Seller unless accepted by Seller in a written amendment to this Agreement. Acceptance of any such requested modification or cancellation shall be at Seller's discretion, and shall be upon such terms and conditions as Seller may require.

7. **Special Tooling:** A tooling charge may be imposed for any special tooling, including without limitation, dies, fixtures, molds and patterns, acquired to manufacture items sold pursuant to this contract. Such special tooling shall be and remain Seller's property notwithstanding payment of any charges by Buyer. In no event will Buyer acquire any interest in apparatus belonging to Seller which is utilized in the manufacture of the items sold hereunder, even if such apparatus has been specially converted or adapted for such manufacture and notwithstanding any charges paid by Buyer. Unless otherwise agreed, Seller shall have the right to alter, discard or otherwise dispose of any special tooling or other property in its sole discretion at any time.

8. **Buyer's Property:** Any designs, tools, patterns, materials, drawings, confidential information or equipment furnished by Buyer or any other items which become Buyer's property, may be considered obsolete and may be destroyed by Seller after two (2) consecutive years have elapsed without Buyer placing an order for the items which are manufactured using such property. Seller shall not be responsible for any loss or damage to such property while it is in Seller's possession or control.

9. **Taxes:** Unless otherwise indicated on the face hereof, all prices and charges are exclusive of excise, sales, use, property, occupational or like taxes which may be imposed by any taxing authority upon the manufacture, sale or delivery of the items sold hereunder. If any such taxes must be paid by Seller or if Seller is liable for the collection of such tax, the amount thereof shall be in addition to the amounts for the items sold. Buyer agrees to pay all such taxes or to reimburse Seller therefore upon receipt of its invoice. If Buyer claims exemption from any sales, use or other tax imposed by any taxing authority, Buyer shall save Seller harmless from and against any such tax, together with any interest or penalties thereon which may be assessed if the items are held to be taxable.

10. **Indemnity For Infringement of Intellectual Property Rights:** Seller shall have no liability for infringement of any patents, trademarks, copyrights, trade dress, trade secrets or similar rights except as provided in this Part 10. Seller will defend and indemnify Buyer against allegations of infringement of U.S. patents, U.S. trademarks, copyrights, trade dress and trade secrets (hereinafter 'Intellectual Property Rights'). Seller will defend at its expense and will pay the cost of any settlement or damages awarded in an action brought against Buyer based on an allegation that an item sold pursuant to this contract infringes the Intellectual Property Rights of a third party. Seller's obligation to defend and indemnify Buyer is contingent on Buyer notifying Seller within ten (10) days after Buyer becomes aware of such allegations of infringement, and Seller having sole control over the defense of any allegations or actions including all negotiations for settlement or compromise. If an item sold hereunder is subject to a claim that it infringes the Intellectual Property Rights of a third party, Seller may, at its sole expense and option, procure for Buyer the right to continue using said item, replace or modify said item so as to make it noninfringing, or offer to accept return of said item and return the purchase price less a reasonable allowance for depreciation. Notwithstanding the foregoing, Seller shall have no liability for claims of infringement based on information provided by Buyer, or directed to items delivered hereunder for which the designs are specified in whole or part by Buyer, or infringements resulting from the modification, combination or use in a system of any item sold hereunder. The foregoing provisions of this Part 10 shall constitute Seller's sole and exclusive liability and Buyer's sole and exclusive remedy for infringement of Intellectual Property Rights.

If a claim is based on information provided by Buyer or if the design for an item delivered hereunder is specified in whole or in part by Buyer, Buyer shall defend and indemnify Seller for all costs, expenses or judgments resulting from any claim that such item infringes any patent, trademark, copyright, trade dress, trade secret or any similar right.

11. **Force Majeure:** Seller does not assume the risk of and shall not be liable for delay or failure to perform any of Seller's obligations by reason of circumstances beyond the reasonable control of Seller (hereinafter 'events of Force Majeure'). Events of Force Majeure shall include without limitation, accidents, acts of God, strikes or labor disputes, acts, laws, rules or regulations of any government or government agency, fires, floods, delays or failures in delivery of carriers or suppliers, shortages of materials and any other cause beyond Seller's control.

12. **Entire Agreement/Governing Law:** The terms and conditions set forth herein, together with any amendments, modifications and any different terms or conditions expressly accepted by Seller in writing, shall constitute the entire Agreement concerning the items sold, and there are no oral or other representations or agreements which pertain thereto. This Agreement shall be governed in all respects by the law of the State of Ohio. No actions arising out of the sale of the items sold hereunder or this Agreement may be brought by either party more than two (2) years after the cause of action accrues.

PD4099 9/88



Parker Hannifin Corporation
6035 Parkland Blvd.
Cleveland, Ohio 44124-4141
Telephone: (216) 896-3000
Fax: (216) 896-4000
www.parker.com

Parker Hannifin Corporation

About Parker Hannifin Corporation

Parker Hannifin is a leading global motion-control company dedicated to delivering premier customer service. A Fortune 500 corporation listed on the New York Stock Exchange (PH), our components and systems comprise over 1,400 product lines that control motion in some 1,000 industrial and aerospace markets. Parker is the only manufacturer to offer its customers a choice of hydraulic, pneumatic, and electromechanical motion-control solutions. Our Company has the largest distribution network in its field, with over 7,500 distributors serving nearly 400,000 customers worldwide.

Parker's Charter

To be a leading worldwide manufacturer of components and systems for the builders and users of durable goods. More specifically, we will design, market and manufacture products controlling motion, flow and pressure. We will achieve profitable growth through premier customer service.

Product Information

North American customers seeking product information, the location of a nearby distributor, or repair services will receive prompt attention by calling the Parker Product Information Center at our toll-free number: 1-800-C-PARKER (1-800-272-7537). In Europe, call 00800-C-PARKER-H (00800-2727-5374).

The Aerospace Group

is a leader in the development, design, manufacture and servicing of control systems and components for aerospace and related high-technology markets, while achieving growth through premier customer service.



The Climate & Industrial Controls Group

designs, manufactures and markets system-control and fluid-handling components and systems to refrigeration, air-conditioning and industrial customers worldwide.



The Fluid Connectors Group

designs, manufactures and markets rigid and flexible connectors, and associated products used in pneumatic and fluid systems.



The Seal Group designs, manufactures and distributes industrial and commercial sealing devices and related products by providing superior quality and total customer satisfaction.



The Hydraulics Group

designs, produces and markets a full spectrum of hydraulic components and systems to builders and users of industrial and mobile machinery and equipment.



The Filtration Group

designs, manufactures and markets quality filtration and clarification products, providing customers with the best value, quality, technical support, and global availability.



The Automation Group is a leading supplier of pneumatic and electromechanical components and systems to automation customers worldwide.



The Instrumentation Group is a global leader in the design, manufacture and distribution of high-quality critical flow components for worldwide process instrumentation, ultra-high-purity, medical and analytical applications.





Mobile Cylinder Div.
P.O. Box 239
Youngstown, OH 44501-0239
Tel: (330) 746-8011
Fax: (330) 746-1148
www.parker.com

Catalog HY18-0001/US
5M, 2/01